

# The Effect of Entrepreneurial Orientation and External Environment on Business Strategy and Firm Performance

ANSIR, SRI WIYATI MAHRANI

Department of Management FEB

Universitas Halu Oleo

Kampus Bumi Tridharma Anduonohu Kendari 93232

INDONESIA

ansir994@gmail.com

EDI CAHYONO

Department of Management FEB

Universitas Halu Oleo

Kampus Bumi Tridharma Anduonohu Kendari 93232

INDONESIA

edi.cahyono@uho.ac.id, edi\_cahyono@innov-center.org

*Abstract:* - The purpose of this study was to test and analyze the effect of entrepreneurial orientation and external environment on business strategy and firm performance on small and medium enterprises in West Java. The study was done using the survey method. There are 163 Small and Medium Enterprises (SME's) participated in this research from 10 regencies in West Java. The method that used in this study is explanatory research method, using a questionnaire as a data collection tool that is distributed to 163 SME in West Java. Analysis of data in this study used descriptive analysis and Structural Equation Modeling (SEM) analysis. The result showed that entrepreneurial orientation and external environment has significant effect on business strategy. Entrepreneurial orientation, external environment and business strategy has significant effect on firm performance. These results generalized the previous researches.

*Key-Words:* - entrepreneurial orientation, external environment, business strategy firm performance, Structural Equation Modeling

## 1 Introduction

Entrepreneurship orientation was introduced by Miller and Friesen in [1], then developed by Lumpkin and Dess [2], Dess and Lumpkin [3] and further investigated by many researchers and observers of small and medium enterprises (SMEs) in order to drive improved performance of SMEs, Even the successful implementation Entrepreneurship orientation on SMEs to encourage the application of this concept to the giant company [4]. This view is in line with the recommendations of the Asia Foundation and the Indonesia Forum Foundation (1998), which essentially that the small and medium enterprise development is more focused on the establishment of entrepreneurial spirit and orientation of the mere capital assistance and technical skills like that have been implemented by the government.

Entrepreneurial orientation has been noted as a key ingredient for organizational success and has been found to lead to higher performance [5]. It is further argued that firms that possess higher levels of entrepreneurial orientation will perform better than those with lower levels of entrepreneurial orientation [6]. Higher levels of entrepreneurial orientation allow firms to have the ability to identify and seize opportunities in a way that differentiates them from non-entrepreneurial firms [7]. From the very emergence of the concept up until today, entrepreneurial orientation has received a lot of attention. Not only has the entrepreneurial orientation allowed us to better understand drivers behind the strategy and development path of particular organization [8], but has also enabled us to comprehend relations between the variable in place and different organizational and environmental factors. Although a lot of research on

the topic has already been done, global technological, economic and social changes condition the necessity for new findings in light of these changes. Complexity and interdependence of factors constituting modern business environment affect emergence of new variable(s) creation that alter the existing relations.

All companies encounter similar problems in the marketplace regardless of the size of the business entity. However, SMEs will inevitably control fewer resources and be part of smaller information networks. Likewise, competencies within these companies will be less specialized. In addition, operating and control mechanisms of operations will be significantly different in SMEs than in large enterprises. Bonaccorsi [9] points out that the differences in the size of the company will not only be reflected in the quantity of disposable resources. These differences will be reflected in many other ways due to a number of characteristics immanent to the SMEs when compared to large companies. Harvie [10] stated that the level of significance of the role of SMEs in an economy can be seen from the ratio between the numbers of business units outside the agricultural sector of the population. Benchmark figures used and become the best practices in the world to maintain the ratio between the numbers of people with industrial units is 1 to 20, meaning that every 20 inhabitants there should be one industrial unit. This in hand encouraged us to conduct a research which could explain in more details nature of relations of entrepreneurial orientation within SMEs. Therefore, we should study the influence of entrepreneurial orientation and external environment on business strategy and firm performance in the context of SMEs in Indonesia.

## 2 Literature Review, Hypotheses and Conceptual Framework

Entrepreneurial orientation is a multidimensional measure of firm level entrepreneurship, comprised of innovativeness, proactiveness, risk taking, competitive aggressiveness and autonomy. Many early studies contributed to the gradual establishment of entrepreneurial orientation as a theoretically and logically legitimate construct representing the entrepreneurial nature of a firm [7].

The role of the environment is one of being a contingent factor on the firm in terms of the opportunities it creates and the threats it poses [11]. This is captured in the various types of risks that the firm faces because of the impending threats and opportunities that arise from the firm's external

environment. These risks are a function of the complexity and uncertainty associated with the environment [12], which can have a significant impact on a firm's success

The business strategy is meant here is the strategy of industrial enterprise single (single industry) or strategy at the level of business unit (business unit strategies), namely the formulation and implementation of the strategy by companies that are relatively autonomous (are relatively autonomous), though it may be the company as part of the corporation complex [13].

Motowidlo and Scotter [14] stated that Two dimensions of job performance, which are task performance and contextual performance. Task performance (or technical job performance) is the behavior associated with maintaining and servicing an organization's technical core. By contrast, contextual performance (or interpersonal job performance) is a function of one's interpersonal skill knowledge that supports the broader social environment in which the technical core must function.

### 2.1. The Relationship between Entrepreneurial orientation and Business Strategy

Entrepreneurial orientation expressed in various ways and one that is widely accepted is the definition proposed by Miller [1] which states that entrepreneurial orientation with regard to product-market innovation, take risk, and behaves proactively. With the challenges of technology and globalization, then even though innovation is commonplace at any time, but with the challenge of technology and globalization, innovation becomes a catalyst for entrepreneurial orientation [15].

Entrepreneurial orientation (EO) refers to the strategy making processes that provide organizations with a basis for entrepreneurial decisions and actions [16].

In an era of global, ability to take the right decision, creativity, innovation, risk taking, proactive to change will determine the success of an organization, but to achieve success, enterprise organizations need to formulate appropriate strategies are able to anticipate changes in the market and observing the environment, especially the external environment such as economic conditions, technology, government policy, political and socio-cultural conditions [17].

H1 : Entrepreneurial Orientation has significant influence to Business Strategy

**2.2. The Relationship between External Environment and Business Strategy**

Naman and Slevin [18] stated that the bottom line conclusion concerning this normative model and empirical test is that ‘fit matters.’ It was not intuitively obvious that such disparate variables of environment, entrepreneurship, organicity and mission strategy could be used to determine how a firm is matched to its current situation. As environments become more demanding in the future, it appears safe to argue that fit will matter even more. Successful firms will engage in a continuous process of organizational learning and adaptation. Managers will be charged to modify continuously the variables in their control in order to maximize the fit score for their firm. This model provides some basis for specifying fit and encouragement that fit as a construct is empirically related to firm performance.”

H2 : External Environment has significant influence to Business Strategy

**2.3 The relationship between entre-preneurial orientation and firm performance**

Entrepreneurial orientation has positive and significant influence on firm performance [19].

The relationship between entrepreneurial orientation and firm performance has been at the forefront of entrepreneurship literature for many years. From early studies, examination of new venture performance to the breadth of recent literature examining the EO construct, researchers have placed great emphasis on the relationship between entrepreneurship and performance. Scholars have primarily theorized a positive relationship between entrepreneurial orientation and the growth and profitability of the firm [20]. However, studies have often differed in their approaches to measuring EO, with some examining overall EO in relation to performance and others examining individual dimensions of EO and performance.

H3 : Entrepreneurial Orientation has significant influence to Firm Performance

**2.4 The relationship between external Environment and firm performance**

Dess, Lumpkin, and Covin in [16] stated that the relationship between the Entrepreneurial Strategy Making (ESM) with performance (performance)

depends on the strategies and the environment. Culhane [22] found that the entrepreneurial orientation partially not determine the company's performance, while through the interaction of the strategy process and changes in economic conditions in each country, entrepreneurial orientation significant effect on the performance of the company.

H4 : External Environment has significant influence to Firm Performance

**2.5. The relationship between Business Strategy and firm performance**

The business strategy is the strategy of industrial enterprise single (single industry) or strategy at the level of business unit (business unit strategies), namely the formulation and implementation of the strategy by companies that are relatively autonomous (are relatively autonomous), though it may be the company as part of the corporation complex [22].

The business strategy is influenced by the macro and micro environment of the organization and significantly direct functional strategy. Business strategies have significant effects on the functional performance of the company [23].

**2.6. The relationship between entrepreneurial orientation and external environment on business strategy and firm performance**

Strategic planning sophistication, perception of environmental uncertainty, and business type (small business venture versus entrepreneurial venture) all are important variables in understanding the planning/ performance relationship for small business and entrepreneurial firm [24].

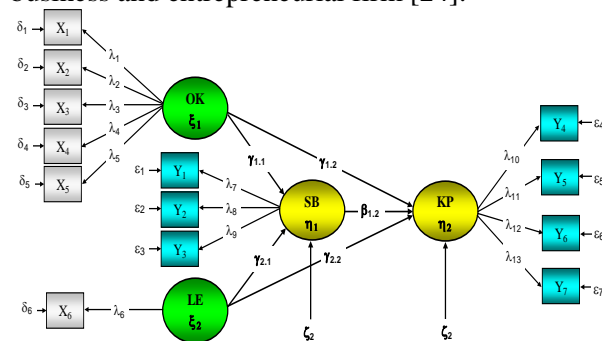

Figure 1. Conceptual Framework

**3 Methodology**

The distribution of population in 25 districts / cities added grouping region fostering cooperatives and small and medium businesses that are used by the Department of Cooperatives and SMEs in West Java Province. Total population in this study were 192

140 SMEs. While the sampling technique used was cluster sampling with total sample:

$$U_p = \frac{1}{2} \ln \left( \frac{1+0.30}{1-0.30} \right) + \frac{0,30}{2(163-1)} = 0,31045$$

$$n = \frac{(1,96+1,96)^2}{(0,31045)^2} + 3 = 162,43 \approx 163$$

Analyses tool used in this research is Structural Equation Modeling (SEM). Entrepreneurial orientation observed in 5 (five) indicators: autonomy, innovation, risk taking, proactive, and competitive aggressiveness. The independent variable is the performance of the company, with indicators on the financial perspective, customer perspective, internal business processes and learning and growth perspective.

### 4 Results and Discusion

Through the relationship between the latent variables in Figure 1 can be calculated much influence each of the exogenous variables on endogenous variables. For scale of the influence entrepreneurial orientation ( $\xi_1$ ) and external environment ( $\xi_2$ ) business strategy ( $\eta_1$ ) obtained the results as presented in Table. 1.

Table 1

The influence entrepreneurial orientation ( $\xi_1$ ) and external environment ( $\xi_2$ ) business strategy ( $\eta_1$ )

<i>Latent Variable</i>	coefficient Effect	Direct Impact	Indirect Influence	Total
$\xi_1$	0,46 13	21,2 8 %	4,31 %	25,5 9 %
$\xi_3$	0,26 04	6,78 %	4,31 %	11,0 9 %
Total simultaneously effect =				36,68 %

Simultaneously variable entrepreneurial orientation and the external environment can explain the changes in business strategy by 36.68% and the remaining 63.32% is explained by other factors not examined. Among the exogenous variables, entrepreneurial orientation provides a greater contribution to business strategy rather than the external environment.

While the effect of entrepreneurial orientation ( $\xi_1$ ) external environment ( $\xi_2$ ) and business strategy ( $\eta_1$ ) on firm performance ( $\eta_2$ ) presented in Table. 2.

Table 2

The influence entrepreneurial orientation ( $\xi_1$ ) and external environment ( $\xi_2$ ) to business strategy ( $\eta_1$ ) and Firm Performance ( $\eta_2$ ).

<i>Latent Variable</i>	coefficient Effect	Direct Impact	Indirect Influence	Total
$\xi_1$	0,29 84	8,91 %	12,5 3 %	21,4 4 %
$\xi_2$	0,26 63	7,09 %	9,48 %	16,5 7 %
$\eta_1$	0,58 45	34,1 7 %	16,3 1 %	50,4 8 %
Total simultaneously effect =				88,49 %

Simultaneously variable entrepreneurial orientation, the external environment and business strategy are able to explain the changes that occur in the variable performance of the company amounted to 88.49% and the remaining 11.51% is explained by other factors that are not researched. Among the three exogenous variables, business strategy contributed the most to the company's performance, then the entrepreneurial orientation and the external environment.

Table 3

Significance test Simultaneous Effect of orientation Entrepreneurship, External Environmental on Business Strategies and Corporate Performance

R <sup>2</sup>	F-count	F <sub>critis</sub> (db: 3;159)	Conclusion
0,8849	407,3 9	2,661	There is a significant effect

Can be seen in Table 3 coefficient of determination (R<sup>2</sup>) entrepreneurial orientation, the external environment and business strategy for the company's performance amounted to 0.8849, meaning that together entrepreneurial orientation,

the external environment and business strategy contributed 88.49% in improving the performance of the company, Furthermore, the value of the F-count greater than F-critis shows that at 95% confidence level can be concluded there is significant influence of entrepreneurial orientation, the external environment and business strategies simultaneously on company performance.

Structurally, the relationship between entrepreneurial orientation and external environment on business strategy and firm performance can be described as Figure 2.

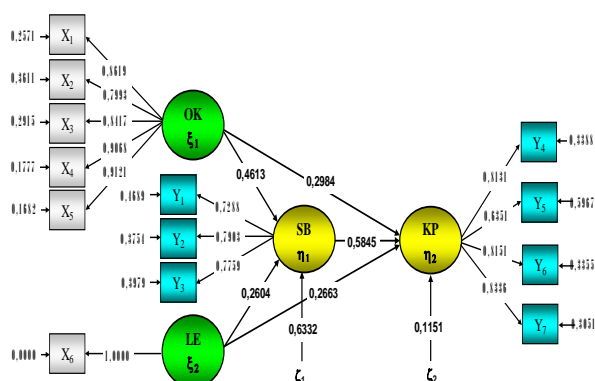

Figure 2. Line Diagram of the influence between entrepreneurial orientation and external environment on business strategy and firm performance

The relationship between entrepreneurial orientation, the external environment and business strategy with the performance of the company stated in the seventh hypothesis of this study, namely: an entrepreneurial orientation, the external environment and business strategies has significant and positive effect on the performance in Small and Medium Enterprises in West Java. This hypothesis test results prove the hypothesis, in which the entrepreneurial orientation, the external environment and business strategies has significant positive effect on the performance in small and medium enterprises in West Java.

This fact showed that the entrepreneurial orientation, the external environment and business strategy both partially and simultaneously influence the performance of small and medium enterprises in West Java. This means that with the strengthening of entrepreneurial orientation and upgrading of small and medium businesses in reducing environmental uncertainty will encourage the birth of the option the right strategy, which together improve the performance of small and medium enterprises in West Java.

The magnitude of the direct influence of entrepreneurial orientation and external environment

together on the performance of small and medium enterprises in West Java 16.00% whereas 22.45% indirectly. Thus, the total effect together entrepreneurial orientation and the external environment in contributing to the improvement of the performance of small and medium enterprises in West Java amounted to 38.45%.

While simultaneously, the amount of testing the effect of entrepreneurial orientation, the external environment and business strategy for the company's performance amounted to 0.8849. That is, together entrepreneurial orientation, the external environment and business strategy contributed 88.49% in shaping the performance of SMEs in West Java. This research has limitations thus cannot be generated for all SME in West Java particularly and generally in Indonesia. For the future study, the researchers should focus on other organizations either on private or government sectors in other states in Indonesia. In addition, the future research also should include both questionnaires and depth interview session together in this study as it will provide more comprehensive outcome.

## 5 Conclusion

The result shows that entrepreneurial orientation and external environment has significant influence on business strategy. Entrepreneurial orientation, external environment and business strategy has significant influence on firm performance. This result supported the founding [1, 2, 16, 17, 19, 21, 23, 24, 25]. In the future, these results will be combine with twinning strategy as presented in [26], and informal leadership and communication as presented in [27].

The effects of entrepreneurial orientation on business strategy have greater than the influence of the external environment on business strategy. It appears from two things, namely: 1) the path coefficient entrepreneurial orientation of the business strategy of the path coefficient 0.4613 while the external environment to the business strategy of only 0.2604; and 2) the effect of entrepreneurial orientation 25.59% increase in business strategy while the external environment impact by 11.09% increase in business strategy. It also can mean two things: 1) entrepreneurship orientation of small and medium enterprises in West Java is much more dominant in shaping business strategy rather than the external environment; and 2) the more dominant business strategy is actually determined by the entrepreneurial orientation of the external environment.

The effect of business strategy for the company's performance is greater than the influence of

entrepreneurial orientation or the external environment on the performance of the company. This can be proved from two things 1) business strategies path coefficient of 0.5845 while the entrepreneurial orientation path coefficient of 0.2984 and the external environment path coefficient of 0.2663; and 2) a business strategy by 50.47% effect in improving corporate performance while entrepreneurial orientation influenced by 21.44% and the external environment impact by 16.57% in improving corporate performance. This means that: 1) the business strategy of small and medium enterprises in West Java is much more dominant in shaping the company's performance rather than entrepreneurial orientation and the external environment; and 2) the company's performance more dominant actually determined by the choice of the right business strategy rather than entrepreneurial orientation and the external environment.

The entrepreneurial orientation, the external environment and business strategy contributed 88.48% in shaping the performance of small and medium enterprises in West Java, while another factor is only 11.52%. This proves that: 1) the performance of small and medium enterprises in West Java was formed by three major factors that become variables of this study, the entrepreneurial orientation, the external environment and business strategy; 2) the study was able to prove significant linkage between the company's performance, particularly on small and medium enterprises in West Java with an entrepreneurial orientation, the external environment and business strategy; 3) entrepreneurial orientation, the external environment and business strategy are the three main factors deciding the company's performance, especially for small and medium businesses.

The orientation of entrepreneurship as a process based on the business management methods, practices and decision-making styles particular is a key factor in the management of companies, especially small and medium enterprises in West Java. This is evident from: 1) Category entrepreneurial orientation (3,914) is higher than the external environment (2,801) and business strategy (3,293); 2) the contribution of entrepreneurial orientation (25.59%) is more dominant than the external environment (11.09%) in shaping business strategy, where business strategies contribute 50.47% of the company's performance; 3) entrepreneurial orientation attached to the leadership (human resources) in the company, which is a major resource in running the company. This shows that, efforts to develop small and medium enterprises

should start from the development of human resources in the field of entrepreneurship skills and business management capabilities, both of which are embodied in entrepreneurial orientation.

#### References:

- [1] D. Miller, and P. H. Friesen, Innovation in conservative and entrepreneurial firms: Two models of strategic momentum, *Strategic Management Journal*, Vol. 3, 1982, pp. 1-25.
- [2] G. T. Lumpkin, and G. G. Dess, Clarifying the entrepreneurial construct and linking it to performance. *Academy of Management Review*, Vol. 21, No. 1, 1996, pp. 135-172.
- [3] G. G. Dess, and G. T. Lumpkin, *Strategic Management: Creating Competitive Advantages*, McGraw-Hill/Irwin, 2003.
- [4] W. Guth, and Ginsberg. Corporate Entrepreneurship. *Strategic Management Journal*, Vol. 11, 1990, pp: 5-15.
- [5] S.A. Zahra, A Canonical analysis of corporate entrepreneurship antecedent and impact on performance, *Proceeding Of The National Academy Of Management*. 46. 1986, pp. 71-75.
- [6] A. Rauch, J. Wiklund, G. T. Lumpkin, ad M. Frese, Entrepreneurial orientation and business performance: An assessment of past research and suggestions for the future. *Entrepreneurship, Entrepreneurship Theory & Practice*, Vol. 33, No. 3, 2009.
- [7] J. G. Covin, K. M. Green, and D. P. Slevin, Strategic process effects on the entrepreneurial orientation - sales growth rate relationships, *Entrepreneurship Theory and Practice*, Vol. 30, No. 1, 2006, pp. 57-81.
- [8] A. M. Moreno and J. C. Casillas, Entrepreneurial orientation and growth of SMEs: A causal model, *Entrepreneurship Theory and Practice*, Vol. 32, No. 3, 2008, pp. 507-528.
- [9] A. Bonaccorsi, What do we know about exporting by small Italian manufacturing firms?, *Journal of International Marketing*, Vol. 1, 1992, pp.49-75.
- [10] C. Harvie, *Regional SMEs and Competition in the Wake of the Financial and Economic Crisis*, International Conference on Impact of Crisis on Trade, Regionalism and Globalization in Asia and Australia, Australia: University of Wollongong, 2002.
- [11] P. K. Chathoth, Co-alignment between Environment Risk, Corporate Strategy, Capital Structure, and Firm Performance: An Empirical Investigation of Restaurant Firms. *Unpublished*

- Thesis, Virginia Polytechnic Institute and University, 2002.*
- [12] T. Mthanti, The impact of effectuation on the performance of South African medium and high technology firms. *Unpublished PhD Thesis*, University of Witwatersrand. 2012.
- [13] M. E. Porter, *Competitive Advantage: Creating and Sustaining Superior Performance*, New York, USA: The Free Press, 1990.
- [14] S. J. Motowidlo, and J. R. Van Scotter, Evidence that task performance should be distinguished from contextual performance. *Journal of Applied Psychology*, Vol. 79, 1994, pp.475-480.
- [15] Viciana, Generation and Development of New Innovative Project, venture management or corporate, *Entrepreneurship, Economic industrial*, Vol. 310, 1996, pp 79-98.
- [16] G. Dess, G. T. Lumpkin, and J. G. Covin, Entrepreneurial Strategy making and Firm Performance: Tests of Contingency and Configurational Models, *Strategic Management Journal*, Vol. 18, No. 9, 1997, pp. 677-695.
- [17] T. L. Wheelen, J. D. Hunger, *Strategic Management and Business Policy*, 9<sup>th</sup> Edition. New Jersey: Prentice Hall, 2004.
- [18] J. Naman, and D. Slevin, Entrepreneurship and The Concept of Fit: A Model and Empirical Tests, *Strategic Management Journal*, Vol. 14, 1993, pp. 137-153.
- [19] Ansir, S. Wiyati M, and E. Cahyono, The Influence of entrepreneurial orientation to firm performance, *Proceeding of WSEAS Joint Conferences*, Seoul, 2015.
- [20] A. Gaudici, *Sensing together: an exploration of the support of network intermediaries to firms' and entrepreneurs' search for new opportunities*, Unpublished Thesis, Granfield University, 2013.
- [21] J. M. H. V. Culhane, , *The Entrepreneurial orientation-Performance linkage in high technology firm : an international comparative study*. 300 North Zeeb Road, United States: ProQuest Information and Learning Company, 2003.
- [22] M. E. Porter, *Competitive Advantage: Creating and Sustaining Superior Performance*, New York, USA: The Free Press, 1990.
- [23] F. T. Movondo, Environment and strategy as antecedents for marketing effectiveness and organizational performance, *Journal of Strategic Management*, Vol. 7, 1999, pp. 237-250.
- [24] C. H. Matthews, *Small Firm Strategic Planning: Strategy, Environment and Performance*, University Microfilm International, A Bell & Howell Information Company, 1990.
- [25] M. Gosselin, An Empirical Study of Performance Measurement in Manufacturing Firm, *International Journal of Productivity and Performance Management*, Vol. 54, No. 5/6. 2005, pp.419-437.
- [26] N. Saha, and P. Saha, Twinning Strategy: Is it a Vehicle for Sustainable Organizational Learning and Institutional Capacity Development?, *WSEAS Transactions on Business and Economics*, Vol. 12, 2015, pp. 2224-2899.
- [27] D. Holátová, M. Brezinová, and L. Kantnerová, Strategic Management of Small and Medium-Sized Enterprises, *WSEAS Transactions on Business and Economics*, Vol. 12, 2015, pp. 2224-2899.