

An Efficient Layered FFT Approach for Reduction of PAPR, Spectral Re-growth and CFO on the Performance of an OFDM System

T.DEEPA, R.KUMAR

Department of Electronics & Communication Engineering

SRM University

Kattankulathur, Chennai 603203

INDIA

deepa.t@ktr.srmuniv.ac.in, kumar.r@ktr.srmuniv.ac.in

Abstract—Orthogonal frequency division multiplexing (OFDM) is an attractive multi carrier modulation technique for future broadband wireless transmission systems. However, the OFDM system exhibits high peak to average power ratio (PAPR), large computational complexity by applying discrete Fourier transform (DFT) at the transmitter and inverse DFT (IDFT) at the receiver and sensitivity to carrier frequency offset (CFO), caused by Doppler shift which the carrier frequency difference between the transmitter and receiver. In this paper, we propose a divide & conquer FFT algorithm of an OFDM system to reduce PAPR and also analyze the impact of spectral re-growth and CFO on the performance of an OFDM system with and without D&C FFT approach. Simulation results show that OFDM system based D&C approach can achieve a good balance between complexity and system performance.

Key-Words: - CCDF, CFO, Divide & Conquer Approach, OFDM, PAPR, Spectral Re-growth

1 Introduction

Orthogonal frequency division multiplexing (OFDM) is a very attractive multi carrier modulation technique for the transmission of high bit-rate data in a radio communication [1]-[3]. However, any multicarrier signals with a large number of subcarriers suffer from the drawback of high fluctuations of the envelope signal resulting high crest factor (CF). When passed through a nonlinear device, such as a transmitter power amplifier, the signal may suffer significant spectral spreading and in-band distortion [4]-[7]. These results in low dc to RF power conversion efficiency as back-off of the amplifier average output power is then required [8]. OFDM system carries the message data on orthogonal subcarriers for parallel transmission, combating the distortion caused by the frequency selective channel or equivalently, the inter-symbol-interference in the multi-path fading channel. However, the advantage of the OFDM can be useful only when the orthogonality is maintained. In case the orthogonality is not sufficiently maintained, its performance may be degraded due to inter-symbol interference (ISI) and inter-carrier interference (ICI) [9]. Carrier frequency offsets (CFO) exist between user terminals and the base station because of the precision limitation of oscillators and the Doppler Effect. The impact of CFO on the OFDM system has been first demonstrated in [10]. The OFDM systems are very

sensitive to CFO which attenuates the desired signal and causes ICI, thus leading the performance degradation by reducing the signal to noise ratio (SNR). Divide and Conquer fast Fourier transform (D&C IFFT/FFT) algorithms works by recursively breaking down a problem into two or more smaller IFFT/FFT of the same or related type, until these become simple enough to be solved directly. In this paper, we present OFDM system based D&C IFFT/FFT algorithm which can overcome these problems and achieve the following major advantages [11], [12]

- The power amplifier (PA) can have smaller back off because of the reduced PAPR value.
- Lower the transceiver's complexity
- Low spectral re-growth
- Low sensitivity to CFO
- Power constraints of the battery driven handsets

The impact of CFO, Spectral re-growth and CFO on the OFDM system based on D&C approach is not well addressed in the literature. The goal of this paper is to assess the sensitivity of the OFDM system to CFO, PAPR and spectral re-growth.

The remainder of the paper is organized as follows. In Section 2, the divide and conquer FFT algorithm is described. In section 3, the system model of

OFDM is described. The performance metrics of the system is detailed in section 4. Section 5 is devoted to simulation results. In Section 6, conclusion is presented.

2 Divide & Conquer FFT Algorithm

In this section, a computationally efficient DFT algorithm is described. It is a divide and conquers approach in which a DFT of size N, where N is a composite number is reduced to the computation of smaller DFTs from which the larger DFT is computed. Fig. 1 depicts the D & C based FFT algorithm. We recall the process of the three Layered based FFT structure (Frequency domain, Intermediate domain, time domain) using Divide and-Conquer (D&C) approach to calculate an N-point DFT of the signal [13],[14]

$$x = \{x_n\}, n \in [0, N - 1] \tag{1}$$

The algorithm as follows:

Step1: store the N point sequence x(n) column wise into a $L \times M$ matrix

Where $l \in [0, L - 1]$, $q \in [0, M - 1]$ and $N = L \times M$

Step 2: Compute M point DFT for each X rows and this leads to the following $L \times M$ new array

$$F(l, q) = \sum_{m=0}^{M-1} x(l, m) W_M^{mq}, 0 \leq q \leq M - 1 \tag{2}$$

for each of the rows $l = 0, 1, \dots, L - 1$

Step 3: Multiply the resulting array F (l, q) by the phase factors W_N^{lq} where,

$$W_N = \exp(-j2\pi / N) \tag{3}$$

And generate new matrix G (l, q) defined as

$$G(l, q) = W_N^{lq} F(l, q) \quad 0 \leq l \leq L - 1 \tag{4}$$

$$0 \leq q \leq M - 1$$

Step 4: Finally, compute the L point DFTs for each column of G (l, q) matrix

$$X(p, q) = \sum_{l=0}^{L-1} G(l, q) W_L^{lp}, \tag{5}$$

For each column $q=0, 1, \dots, M-1$ of the array G (l, q)

Step 5: Read the resulting array $L \times M$ matrix row wise.

3 OFDM SYSTEM MODEL

We assume an OFDM system based D&C approach. The block diagram depicting the system is given in Fig. 2. The Each symbol \tilde{x}_n in the symbol vector \tilde{x} , defined as

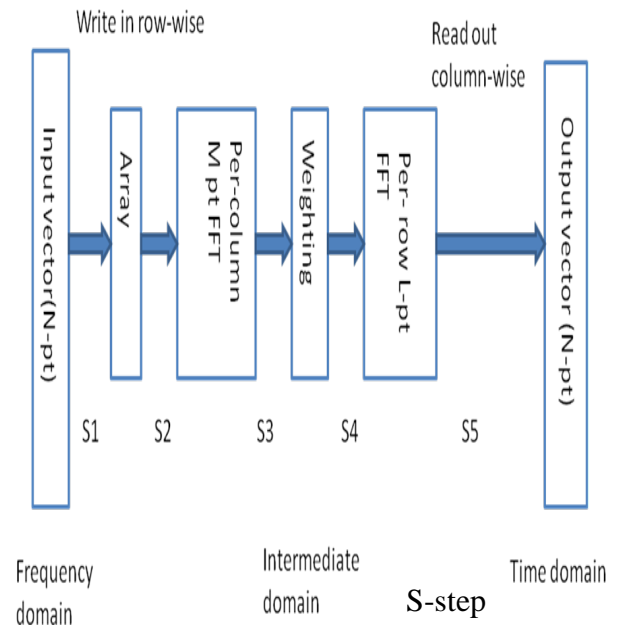

Fig .1. Divide& Conquer FFT algorithm

$\{x_n\}, n \in [0, N - 1]$ is transmitted on the sub channel frequency n by applying an IFFT on \tilde{x} . The occupied spectrum of frequency has been centered on the carrier frequency. The symbol block duration is equal to Nt , where N is the number of sub channels and t is the one symbol duration. The IFFT is equivalent to multiplying \tilde{x}_n by

$$x_n(t) = \frac{1}{N} e^{i2\pi m / Nt} \text{ and summing the contributions}$$

on the different sub channels. Instead of applying N point IFFT, LM point IFFT ($N=L \times M$) is performed in case of OFDM system based D&C approach. The resulting symbols are appended with cyclic prefix (CP). Finally, the baseband signal is up-converted to the carrier frequency w at the transmitter. The resulting signal $x(t)$ is transmitted through a Rayleigh fading channel $y(t)$. Additive white Gaussian noise (AWGN) $n(t)$, is added in the received front-end. The radio frequency (RF) received signal $r(t)$ is finally down-converted to the baseband domain before going back to the frequency domain by the use of an FFT, corresponding to the multiplication of the received vector of samples. The received vector is composed by the signals received on the different sub-carrier frequencies, as defined in $\hat{X} = \hat{X}_{-N/2} \dots \hat{X}_{-N/2-1}$.

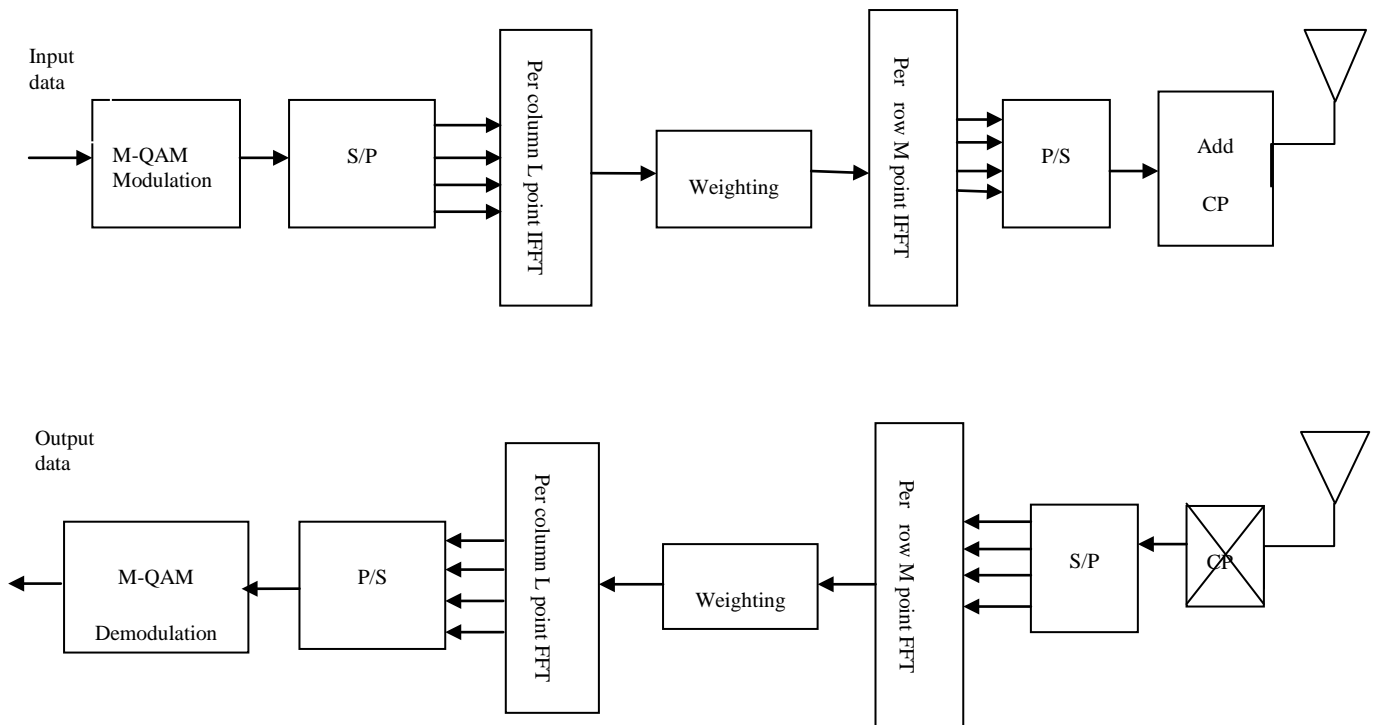

Fig.2. The block diagram of OFDM transceiver

In an OFDM system, the local oscillator at the receive terminal is different from the one at the transmit base-station, the down conversion to the baseband domain is operated with a frequency shift $\Delta\omega$ (CFO), and the received signal is sampled with an initial phase t_0 different from 0 and with a period T' slightly different from the one at the transmitter T . Assume after IFFT transform of the output signal at the time k is X_k , the received signal Y corresponding to the transmitted signal can be expressed as,

$$Y = H_k X_k + n \tag{6}$$

Where, H_k is the complex gain.

The receiver components are the ML point of FFT and CP removal, the demodulator to compute bit metrics, the message bits need to be extracted.

4 EFFECTS OF PAPR, SPECTRAL REGROWTH AND CFO

4.1 Computational Complexity

The complexity of IFFT/FFT transform is compared between the conventional and proposed OFDM receivers. With M ary QAM modulation, a general OFDM receiver includes an N point FFT and the complexity is $N/2 \log_2 N$. For a proposed OFDM system, the receiver provides M point FFTs, L point weighting factors and the complexity is $N/2 \log_2 M + L + L \log_2 L$.

TABLE 1: LAYERED BASED FFT RECEIVER COMPLEXITY IN TERMS OF NUMER OF COMPLEXITY MULTIPLICATIONS

Systems	IFFT/FFT size	Multiplication Complexity	Example
without D&C	256	$N/2\log_2 N$	1024
with D&C	256 (L=64,M=4)	$N/2\log_2 M+L + L\log_2 L$	704
	256 (L=4,M=64)	$N/2\log_2 M+L+L\log_2 L$	780

From Table I, the OFDM receiver based on ML point FFT approach requires less complexity, compared to the general OFDM. This table indicates that complexity strongly depends on the value of L point IFFT/FFT transform.

4.2 Crest Factor (CF)

The general complex representation of OFDM signal can be expressed as

$$X(n) = \frac{1}{N} \sum_{m=0}^{N-1} x e^{\frac{j2\pi m n}{N}}, \quad n = 0, 1, 2, \dots, N-1 \quad (7)$$

Where,

x is the mapped information data

N is the number of subcarriers

X (n) is the IFFT output signal

The PAPR reduction capability is measured by the complementary cumulative distribution function (CCDF) which indicates the probability that the PAPR exceeds a certain threshold value. The CCDF of PAPR can be applied to determine the bounds for the minimum number of redundancy bits required to identify the PAPR sequences. PAPR for the discrete time OFDM signal X(n) is defined as [15],[16]. Mathematically CCDF can be explained with a set of data having the probability density function. In order to find the probability that the PAPR exceeds the PAPR threshold, we consider the complementary CCDF,

$$PAPR = 10 \log \frac{\max |X(n)|^2}{\text{Avg} |X(n)|^2} \quad (8)$$

$$\begin{aligned}
 \hat{F}[X_{\max}(z)] &= pr(X_{\max} > z) \\
 &= 1 - [pr(X_0 < z) \cdot pr(X_1 < z) \dots pr(X_{N-1} < z)] \\
 &= 1 - pr(X_{\max} \leq z) \\
 &= 1 - F[X_{\max}(z)] \\
 &= 1 - \left(1 - e^{-z^2}\right)^N
 \end{aligned}
 \tag{9}$$

Where, z is a PAPR threshold level.

4.3 Carrier Frequency Offset (CFO)

The baseband transmitted signal is converted up to the pass band by a carrier modulation and then, converted down to the baseband by using a local carrier signal of the same carrier frequency at the receiver. The CFO distortion is associated with carrier signal, caused by Doppler frequency shift f_d . Let f_c and f_c' denote the carrier frequencies in the transmitter and receiver, respectively. Let offset denote their difference (i.e., $offset = f_c - f_c'$). Meanwhile, Doppler frequency f_d is determined by the carrier frequency f_c and the velocity v of the receiver as

$$f_d = \frac{v \cdot f_c}{c}
 \tag{10}$$

Where, c is the speed of light.

Let us define the normalized CFO, ϵ , as a ratio of the CFO to subcarrier spacing, Δf , shown as

$$\epsilon = \frac{f_{offset}}{\Delta f}
 \tag{11}$$

5 SIMULATION RESULTS

We consider an OFDM system with N point DFT (N=256 is taken for an example) using 16-QAM modulation (M=16, where, k=4 bits/symbol), simulated by randomly generated data. Since N=LM (where L=64, M=4). Fig.3 shows the CCDF performance of OFDM system with and without D&C IFFT algorithm. From Fig.3, it can be seen that 0.8 dB PAPR reductions can be achieved in OFDM system using LM point IFFT

compared to the OFDM system with N point IFFT. At CCDF=10⁻² level, the proposed system with 16 ary QAM can achieve it at 7.2 dB PAPR, which is about 0.8 dB smaller than OFDM system without D&C approach. Fig. 4 shows the spectral re-growth effects of OFDM system with and without D&C approach. Compared with the conventional OFDM system, the OFDM system based D&C approach has little spectral regrowth, which can increase the immunity of OFDM signals from out of band noise.

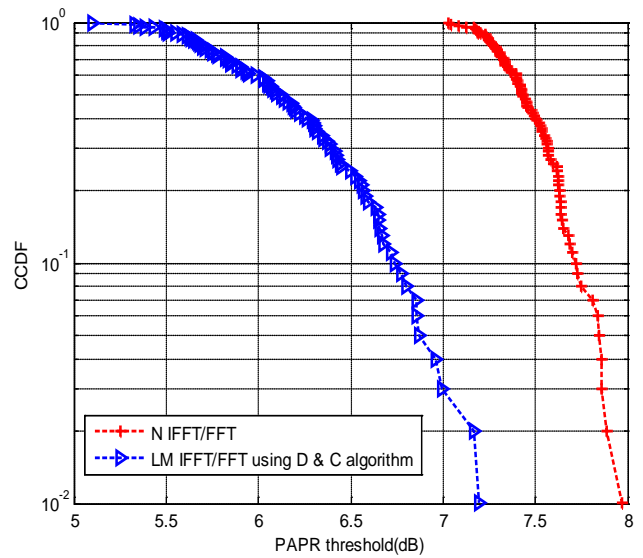

Fig.3 CCDF performance of OFDM systems with and without D & C IFFT approach

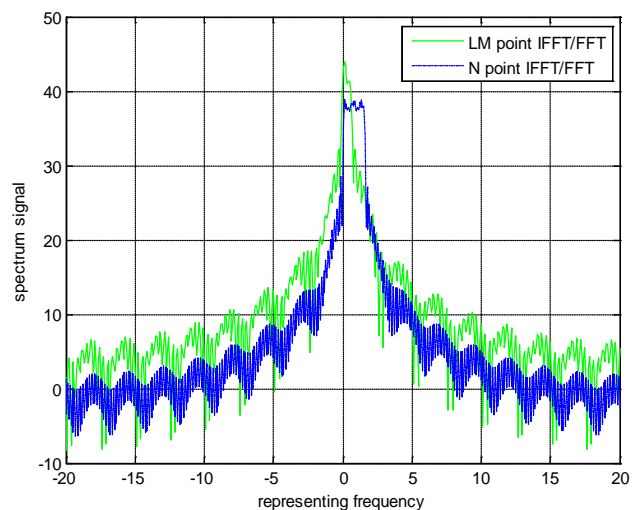

Fig. 4. Impact of the spectral re-growth on the OFDM system performance (solid curves: OFDM system based D& C FFT approach, dashed curves: OFDM system using N point FFT).

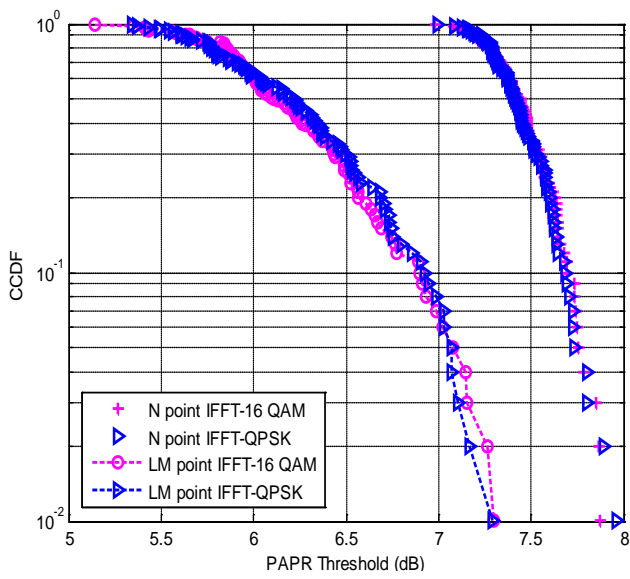

Fig.5. Comparison of CCDF performance of OFDM systems on different modulations

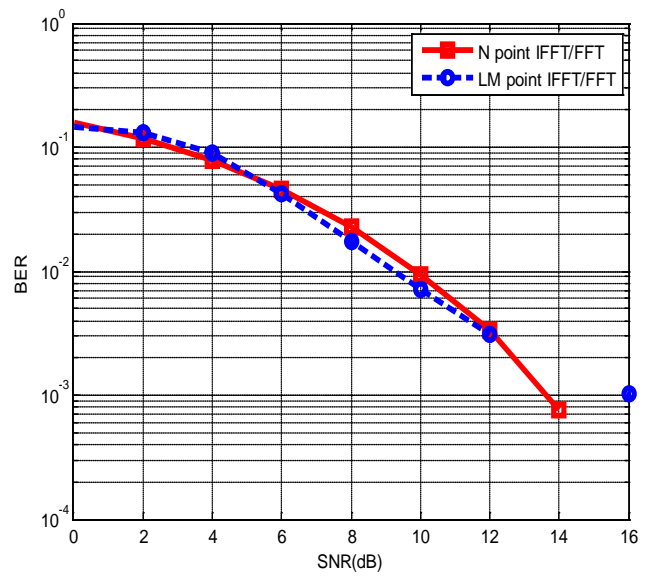

Fig.6 Comparison of BER performance of OFDM system with N point FFT and LM point FFT

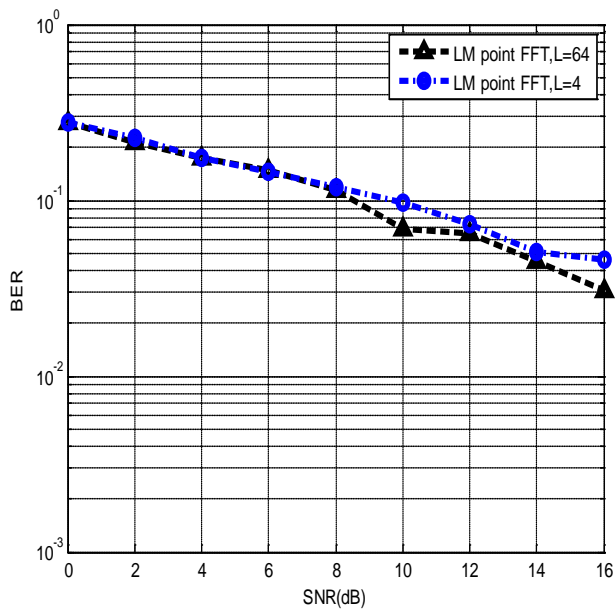

Fig.7. comparison of BER performance of OFDM system with different L point FFT

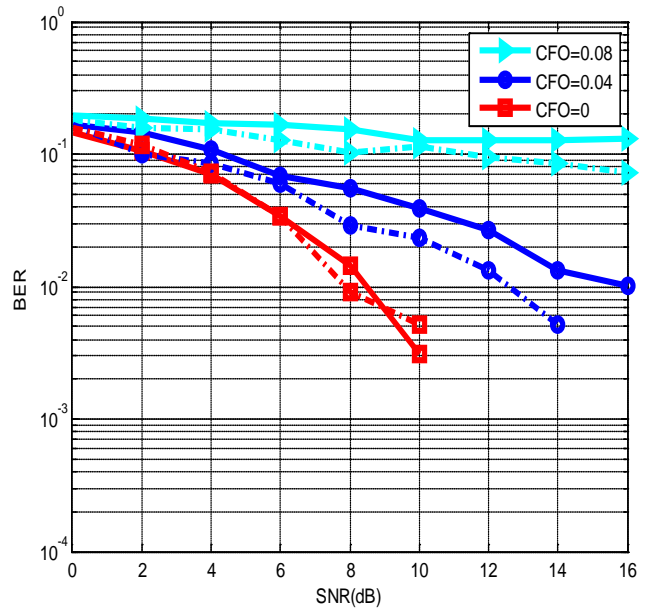

Fig. 8 Impact of the CFO on the OFDM system performance over frequency selective fading channels (solid curves: OFDM system using N point FFT, dashed curves: OFDM system based D&C FFT approach).

Fig.5. illustrates the comparison of CCDF performance of OFDM systems with and without D& C IFFT for QPSK and 16-QAM modulations. It can be seen that the OFDM signal with LM point IFFT using 4 ary PSK achieves same and better PAPR reduction at 10^{-2} CCDF level comparing to the OFDM system using LM point IFFT. Fig.6 shows the BER performance of the OFDM system with LM point FFT and system with N point FFT. It can be seen that the OFDM system with D&C approach achieves same and better BER performance than general OFDM system with N point FFT. It can be seen that when SNR is small, noise enhancement dominates the BER performance of the system and the system with LM point FFT is superior to OFDM with N point FFT when SNR is large. Fig.7 compares the BER performance of OFDM system with different L point FFT. From Fig.7, it can be noticed that the system with L=64 point FFT has same and better BER performance than the system with L=4 point FFT. The impact of CFO on OFDM system performance is simulated for frequency selective fading channel in fig.8.CFO causes a high level of interference between the neighboring symbols that limits strongly the performance of the OFDM systems.

6 CONCLUSIONS

In this paper, we proposed a divide & conquer FFT algorithm for OFDM systems to reduce PAPR and also analyzed the impact of CFO on the performance of an OFDM system with without D&C FFT approach. Simulation results shown that OFDM system based D&C approach can achieve a good balance between complexity and performance. Compared with the conventional OFDM system, the proposed system can significantly improve the system performance by reducing PAPR and reducing computational complexity. By analyzing the impact of CFO on system performance of OFDM system, we have identified the different points of the impact of CFO in OFDM system with and without D&C FFT approach in improving the system performance and have shown that the OFDM system using LM point IFFT/FFT transform is less sensitive to CFO comparing to the OFDM system using N point IFFT/FFT transform.

References

- [1] Ramjee Prasad, OFDM for Wireless Communications Systems,(Aug 31, 2004).
- [2] Andrea Goldsmith, Wireless Communicaiton, Cambridge University Press, Stanford University, 1st edition edition, 2005.
- [3] T.S.Rappaport, Wireless Communications: Principles and Practice.Prentic-Hall Inc.,2002.
- [4] S. H. Han and J. H. Lee "An overview of peak-to-average power ratio reduction techniques for multicarrier transmission", *IEEE Personal Communications*, vol.12, no.2, pp.56 -65 2005
- [5] H. Ochiai and H. Imai "On the distribution of the peak-to-average power ratio in OFDM signals", *IEEE Trans. Communications*, vol. 49, no. 2, pp.282 -289 2001.
- [6] N. Dinur and D. Wulich "Peak-to-average power ratio in high-order OFDM", *IEEE Trans. Communications*,vol.49,no.6,pp.1063-1072 2001
- [7] S. Litsyn and G. Wunder "Generalized bounds on the crest-Factor distribution of OFDM signals with applications to code design", *IEEE Trans. Information Theory*, vol. 52, no. 3, pp.992 -1006 2006
- [8] D. H. Park and H. K. Song "A new PAPR reduction technique of OFDM system with nonlinear high power amplifier", *IEEE Trans. Consumer Electronics*,vol.53, no.2, pp.327 -332 2007
- [9] "Special issue on multi-carrier communications," in *Wireless Personal Communications*. Amsterdam, The Netherlands: Kluwer Academic, vol. 2, no. 1. 1995
- [10] T. Pollet, M. Van Bladel, and M. Moeneclaey, "BER sensitivity of OFDM systems to carrier frequency offset and weiner phase noise," *IEEE Transactions on Communications*, vol. 43, no. 1, pp. 191–193, February-April 1995.
- [11] Zhang, J., Luo, L., Shi, Z,"Quadrature OFDMA systems based on layered FFT structure" *IEEE Transactions on Communications*,2009,pp.850-860.
- [12] Lin Luo,J.Zhang,and Z.Shi ,"BER analysis for asymmetric OFDM systems," in *Proceedings of GLOBECOM'08*,pp. 1-6,New Orleans,La,USA ,November-December 2008.
- [13] J.G.Proakis,Digital Communications, McGraw-Hill, NewYork, NY,USA,4th edition,2001.
- [14] J.R.Barry,E.A.Lee, Digital Communication, 3rd edition.Kluwer Academic Publishers,2003.
- [15] T. A. Wilkinson and A. E. Jones, "Minimization of the peak to mean envelope power ratio in multicarrier transmission schemes by block coding," in *Proc. VTC'95*, July 1995, pp. 825–831.
- [16] T.Deepa,R.Kumar,"Performance of Comparison Metrics On M Qam Ofdm System With High Power Amplifier",in *Proceedings of WICT'12*,pp-909-914,Trivendrum,Kerala, October 2012.