













paradigms of inter-cluster communication between the CHs and the BS; single-hop communication and multi-hop communication. In single hop communication model, the CHs should send the collected directly to the BS. In multi-hop communication model, the CH should discover a route to the BS on which the aggregated data will be sent.

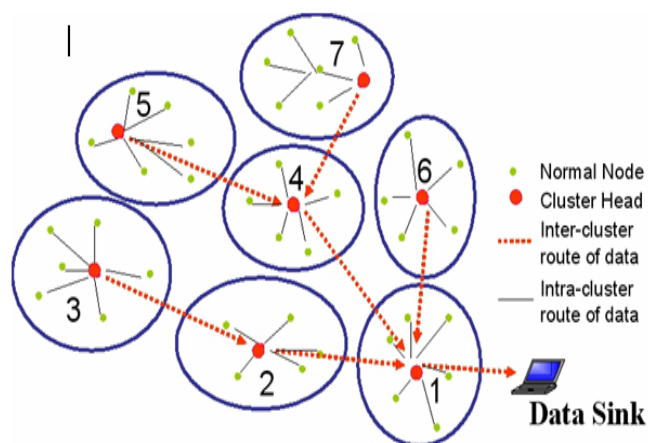

Fig.2. Intra-cluster and inter-cluster communication in WSN

The clustering has various advantages in addition to achieving network scalability. For example, it can reduce the routing tables maintained in each node by localizing the path setup within the cluster. Also by limiting the scope of inter-cluster communication to cluster heads, it can increase the available bandwidth for communication. Moreover, the data collected by sensor nodes can be aggregated by their CHs and thus decreasing the number of packets forwarded to the sink which will result in decreasing the consumed energy and increasing the network lifetime. Another advantage for clustering is that a CH can make schedule activities in the cluster such that the members in that cluster can switch to sleep mode most of the time which will decrease the energy consumption [2].

## 2.2 Clustering techniques properties

The clustering techniques in WSNs could be classified according to a set of common attributes, properties and design goals [11]. Depending on the network model the clustering algorithm can take in their consideration whether the sensor nodes are stationary or mobile. Mobility of nodes or even the BS will make the clustering is very complicated task since the clusters have to change over time due to that the nodes change their membership dynamically. Also the monitored event by the network could be continual or non-continual. For example, in object tracking application, the monitored event is continual while it is intermittent

in early fire detection application. The clustering algorithms in application that have intermittent events tend to be adaptive while they tend to be proactive in the applications that have continual events [2]. Energy Saving Methods in Clustering Algorithms

The clustering algorithms in WSNs provide efficient methods for controlling the nodes in order to reduce the energy consumption and prolong the network life time as follows:

### Cluster Head Formation

One of the early techniques to control cluster formation in WSNs is Random Competition based Clustering (RCC) [29]. Node identification and random number are used by RCC for cluster formation depending on First Declaration Wins Rule. This rule assigns governorship position for the sensor node that declares itself first as a CH to other nodes in its range. Another cluster formation method is broadcasting that can be divided into direct broadcasting and multi-hop broadcasting. The cluster advertisement message in the direct broadcasting is sent form the CH to all other sensors in the selected area. When receiving the advertisement message, the receiving node replies to the CH in addition to refrain itself from receiving any other advertisement messages. In multi-hop broadcasting the CH uses a specific transmission range to send the advertisement message to all other sensors. The receiving node has the ability to decide whether it should re-transmit the received advertisement message to other sensors in its transmission range or not. The multi-hop broadcasting reduces the energy consumption since there is a transmission limit. The sensor nodes which are not close to each other do not need to exchange messages directly. However, the multi-hop broadcasting has a disadvantage of having more delay when compared to the direct broadcasting. The incurred delay is due to that the data, in multi-hop broadcasting, are required to be processed be every node along the multi-hop path which will result in delay in cluster construction.

### Cluster Head Election and Rotation

After cluster formation phase, each cluster has to elect its own CH which acts as a leader. Cluster head usually has two jobs; it is responsible for data aggregation or fusing and it is responsible for forwarding data of its cluster members to the sink node. As the reader could expect, the clusters that have many member nodes consume more energy a than fewer-sensor clusters. The CHs in clusters, that have more members have to receive, aggregate and transmit more data. To preserve energy resource, it

is prefer to elect nodes with high residual energy as cluster heads during cluster head election due to that the CHs are known to have more responsibilities that make them consume more power than other member nodes. Therefore, the role of CH has to be rotated to balance the burden and as consequently improving network life time. Another approach for CHs election is to elect them and rotate the role of the CH them randomly based on some probabilities. The random election will reduce the overhead associated with the election process but it will often results in poor cluster election. Another approach for CH selection is based on minimizing the distance to cluster nodes as this offers reduction in energy usage during forwarding the data to the sink node. In both approaches, the role of the CH has to be rotated in order to distribute the power consumption through the whole network. Other approaches for energy saving in clustering are available such as cluster optimization by using K-hops which is not under scope of this study.

### 3 Methodology and Proposed Technique

In this section, we present a detailed description of the proposed scheme and the system model in addition to illustrating the modifications on routing protocols that were used as inter-cluster routing protocols over HEED and RHEED. First, we introduce the system model which consists of network model and radio model. After that, we discuss the modifications on routing protocols that were used as inter-cluster routing protocols to be suitable for WSN. Finally, we discuss in detail the proposed clustering scheme that is named Rotated-HEED (RHEED) clustering protocol.

#### 3.1 System and Network Model

In this study, we consider a WSN that consists of  $N$  sensor nodes which are deployed randomly over a target area to periodically observe the environmental conditions in that area with a BS located far away from the monitored area. All the collected data should be forwarded in some way to the BS. The following assumptions about the network should hold:

- The sensors are deployed uniformly in the sensing area and there is a BS, which have unlimited resources, located far away from the monitored area.
- All sensor nodes are stationary, not mobile, and they are location un-aware.
- All Sensor nodes have similar capabilities in

term of communication, storage energy and processing resources.

- The sensors can operate in sleep, active or idle mode.
- The sensor nodes can vary the transmission power amount in order to reach the desired destination.
- Symmetric links are assumed, i.e., two sensors A and B can communicate using the same energy level of transmission
- Radio Model

The radio module is responsible for the wireless communication between sensor nodes. In Fig. 3[9], we show the first order radio module used in sensor nodes devices. The *Transmit Electronics* is electronics circuit which performs signal modulation. *Tx Amplifier* (transmit amplifier) is used to amplify the modulated signal and output it to the antenna. The *Receive Electronics* is electronics circuit which decodes the modulated signal.  $E_{elec}$  is the circuit energy needed by *Transmit Electronics* or *Receive Electronics* for modulating or demodulating a bit of data.  $E_{amp}$  is the energy needed by the amplifier circuit to transmit a bit of data to an area of radius  $d = 1$  meter. In a real sensor, the transmit module (*Transmit Electronics* and *Tx Amplifier*) usually stays in low-power sleep mode. It only wakes up when there is any bit that is required to be sent. On the other hand, the receiver module (*Receive Electronics*) wakes up only when waiting to receive messages.

According to first order model, the energy dissipated to transmit  $l$ -bit message for a distance  $d$  is calculated as in the (2):

$$E_{Tx}(l, d) = E_{elec} * l + E_{amp} * l * d^n \quad (2)$$

As mentioned before,  $E_{amp}$  is the energy needed by the amplifier circuit to transmit one bit of data to an area of radius  $d = 1$  meter.  $E_{amp}$  and  $n$  varies according to the distance between the source and the destination;  $E_{amp} = \epsilon_{fs}$  and  $n = 2$  assuming when the  $d < d_0$ , the free space radio energy dissipation model is used, while  $E_{amp} = \epsilon_{mp}$  and  $n = 4$  using the multipath radio energy dissipation model when  $d > d_0$ , where  $d_0$  is a threshold distance that depends on environment conditions.



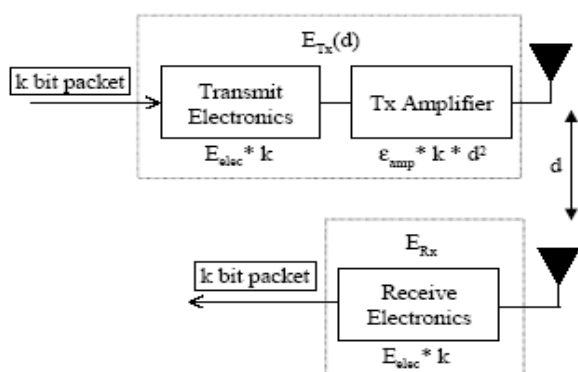

Fig.3. Radio Model of a Wireless Device. (Adapted [9])

The energy needed to receive or demodulate a  $k$ -bit message is calculated as in (3):

$$E_{Rx}(k) = E_{elec} * k \quad (3)$$

### 3.2 DCR, DSR and PEGASIS MODIFICATIONS

After CH election, each cluster head should construct a multi-hop path in order to deliver the gathered data to the sink. In our implementation of these protocols, we have made many modifications on the original versions of these protocols in order to make them suitable for our scenario. The following subsections demonstrate these modifications in details

#### 3.2.1 DSR Modifications

For DSR, after CHs election has been done, the BS will discover the closest CH to it by sending many discovering messages with increasing range until at least one CH replies. Upon determining the closest CH, the BS sends a MULTI-HOP-PATH constructing message to the closest CH. This constructing message will have an empty record (list) listing the address of nodes through which the constructing message have been forwarded. Thus, initially the BS will add its address to this list. When the closest CH receives this message, it will copy the accumulated path to its cache to be used as its multi-hop path in the current round of communication. After that, the closest CH will add its own address to the path list and then forwards the MULTI-HOP-PATH constructing message to its neighbours of CHs. Each receiving CH, who has not received this MULTI-HOP-PATH constructing message before, will also copy the accumulated path to its cache to be used as its multi-hop path and then forward the message to its neighbours after adding its own address to the path list, the process will be terminated when all CHs have received the MULTI-HOP-PATH constructing message.

#### 3.2.2 PEGASIS

For PEGASIS, at the beginning of a round, all the CHs should send a message to the BS using the highest available power level in order to measure their distances to the BS which in turn will send a reply message to the farthest CH from it telling this CH to begin constructing the chain. Then the CHs will use the nearest neighbour algorithm for chain constructing with the last node in the chain is elected to be the leader in the current round of communication.

#### 3.2.3 DCR

For DCR, we omitted the clustering part and used the routing part only. Each CH will firstly measure the distance to the BS using signal strength and then all the CHs will broadcast this information to their neighbours within inter-cluster communication range. After the information exchange has been done, each CH will choose the closest neighbour to the BS as its next-hop. Each CH need to measure its distance to the BS only once thought the network life-time.

### 3.3 Rotated HEED Clustering protocol

The proposed scheme builds on the success of HEED protocol. We have modified its clustering phase to be more energy-efficient. We called the modified version the Rotated HEED. In the Rotated HEED, the clustering operation is divided into rounds and each round has two phases; the setup phase in which the sensors are organized into clusters after receiving a clear request from the BS to construct the clusters and the steady-state phase in which the collected data are forwarded indirectly to the BS via the cluster heads as in HEED. The setup phase in turn is divided into three phases, the initialization phase, the main processing phase and the finalization phase. The following steps describe the proposed protocols which are depicted in Fig. 4.

- 1- At the setup phase in the first round all sensors constructs the cluster heads according to the steps stated in HEED protocol.
- 2- After constructing the clusters in the first round and before entering the steady-state phase, every CH will construct a turn schedule for its members telling every member when its turn to be a CH. So, in the setup phase in the next round there is no need to re-elect the CH as in HEED. Nodes in the cluster will take turns to be cluster heads.
- 3- The nodes within the same cluster in the next rounds will continue rotating the CH role between them until the current CH's residual

energy goes under a specific threshold.

- 4- When the current CH's residual energy goes under a specific threshold, it will send a re-clustering message to the BS via multi-hop route.
- 5- When the BS has received the re-clustering message from at least on CH, it re-broadcasts the re-clustering message to all nodes in the network.
- 6- After having all nodes received the re-clustering message they will goes to step 1 and re-cluster the network.

As in the previous steps the clustering process will be conducted on-demand after the residual energy of at least one CH has fall below a specific threshold. The threshold ( $Thes$ ) is computed using formula (4):

$$Thes = C * CHRE \quad (4)$$

Here,  $C$  is a constant between 0 and 1 which is chosen experimentally, and  $CHRE$  is the residual energy of the CH at the beginning of the last round in which the re-clustering has been occurred.

## 4 Performance Evaluation

Simulation is a flexible approach for performance evaluation of clustering and routing protocols under different conditions. In section 3, we proposed a clustering protocol that improves the network life-time. We also explain the routing protocols we plane to evaluate as inter-cluster routing protocols with our proposed scheme. In this section, we compare the performance of RHEED protocol with the HEED clustering protocol in terms of residual energy and network life-time.

### 4.1 Energy Consumption

As we explained in the previous sections, the units that consume the energy of the sensor node are the radio unit, the sensor unit and the controller unit. For the radio unit we have used the model described in section 3.1.2. In addition to the energy consumed by the radio unit for transmitting and receiving data, we also consider the energy consumed by the sensor unit and the controller unit in order to conduct a realistic performance evaluation of our protocols. The controller unit board and the sensor board work in two modes; the sleep mode and the full operation mode. According to [18] the energy consumed by the sensor board in the sleep mode is almost zero. The energy consumed by the sensor board in the full operation mode is shown in Table 1([18]) in which

mA means milli-ampere and  $\mu A$  means micro-ampere. From the table, we deduce that the current of the sensor unit board in the full operation mode is around  $2/3$  of the radio board current in the receiving mode while the current of the controller unit board, in the full operation mode, is equals to that of the radio in receiving mode.

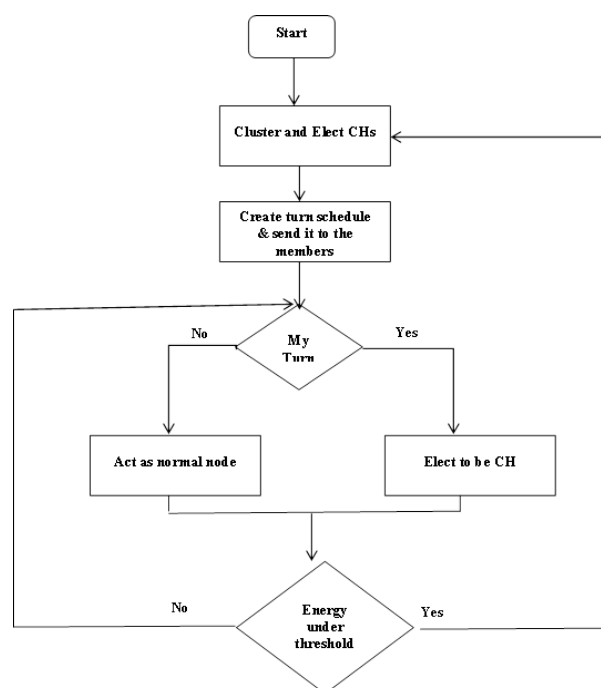

Fig.4. The steps of RHEED algorithm

### 4.2 Simulation Settings

Unless otherwise is specified, we have assumed that we uniformly deployed a network contains 200 nodes in a field with dimensions of 100m x 100m. The BS was located far away from the monitored field at location (50,200). The minimum probability ( $P_{min}$ ) for becoming a CH was set to be 0.0005 which is the same that of [30].

Table 1. Currents of boards in sensor node MICA2DOT

Currents	Example Duty
<b>Processor</b>	
Current (full operation)	1
Current (sleep)	99
<b>Radio</b>	
Current in receive	0.75
Current transmit	0.25
Current sleep	2 $\mu A$ 99
<b>Sensor Board</b>	
Current (full operation)	1
Current (Sleep)	99

The laws of wireless transmission direct that power attenuation of the sender is proportional to the distance square between the destination and the source. The power attenuation can be assumed to be linear with the transmission radius if the distances are small. In practical, there are other factors that could affect the received power, such as physical obstacles or noise. In our experiments, we ignore these factors and, thus, we use the distance between sensors to compute power consumption. This method for computation the power consumption was used in [30]. Table 2 lists the simulation parameters which indicate that most of them are similar to those in [30]. In addition to parameters stated in Table 4-2 the assumptions stated in section 3.1 should hold.

Table 2. List of simulation parameters used

The Parameter	The Value
Deployment Field	100 x 100 m
Data Packet Size	200 bytes
Control Packet	25 bytes
Number of nodes	200
Cluster Radius	30 meters
Sink Position	200
Initial Energy	2 J
$E_{elec}$	50nJ/bit
$efs$	10nJ/bit/m <sup>2</sup>
$E_{fus}$	5nJ/bit/signal
$e_{amp}$	0.0013nJ/bit/m <sup>4</sup>
Threshold Distance $d_0$	87 meters
Deployment Method	Uniform, Random
Round	20 seconds = 5 frames
$P_{min}$	10 <sup>-4</sup>
Constant C	0 – 1

### 4.3 Performance Metrics

The evaluation metrics used to evaluate the performance of the compared protocols are residual energy and network life-time. Some WSN applications require that each sensor should work to ensure that the network have a good coverage. Thus, the network life-time in these applications should be measured by the life-time of the shortest-living node. Some other applications require that only a specific per cent of the nodes should stay alive to achieve network objectives. Hence, in our simulation, the network life-time is measured by three different metrics; last node dies, half node die, and first node dies.

- Residual Energy (RE): we defined the residual energy metric as the average energy remaining in all nodes at specific round.

- First Node Dies (FND): it is the time elapsed in rounds until at least one of the nodes has consumed its whole energy.
- Half Nodes Die (HND): it is the time elapsed in rounds until half of the nodes have depleted their whole energy.
- Last Node Dies (LND): it is the time elapsed in rounds until all the nodes have exhausted their whole energy.

Here the round term refers to the time in seconds elapsed until a re-clustering for the network may occur. There is no difference between round concept in HEED and RHEED in term of time. The round time in HEED and RHEED could be in range of seconds, minutes or even hours. In our simulation, we specified the round time to be 20 seconds. The difference between HEED round and RHEED round is relating to type of actions performed at the beginning of each round. Generally, the round is divided in our simulation into two parts; the clustering time  $T_c$  and the operation time  $T_o$  as depicted in Fig. 5(a). In HEED at the clustering part ( $T_c$ ), the HEED clustering mechanism ( $H_c$ ) will be used at the beginning of each round as depicted in Fig. 5(b). In RHEED at the clustering part, the proposed clustering mechanism (Scheduling mechanism  $S_c$ ) and also HEED clustering mechanism both could be used depending on rules mentioned in previous sections. This case is depicted in Fig. 5(c).

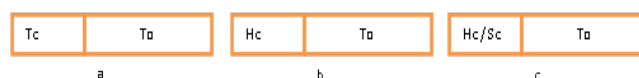

Fig.5. Round concept in HEED and RHEED

### 4.4 Results and Discussion

The results of our simulation are presented and discussed in this section. Every result presented is the mean of 5 experiments. First, we show the comparisons between single-hop RHEED and single-hop HEED. Then, we compare between multi-hop RHEED and multi-hop HEED using the previously discussed inter-cluster routing protocols.

#### 4.4.1 Single-hop RHEED vs. Single-hop HEED

In this set of experiments the nodes were deployed uniformly. Fig. 5 shows the number of live sensors in the network versus number of rounds. The constant C, which is used by RHEED to control the re-clustering process, was chosen to be 0.6 in this scenario. The results from Fig. 5 show that the proposed scheme RHEED performs better than

HEED.

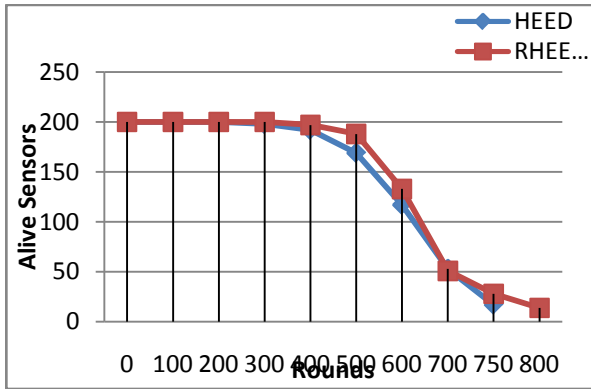

Fig.6. The comparison of the number of alive sensors in HEED and RHEED with a constant value of 0.6.

Fig. 6 depicts the results for both schemes in terms of number of alive nodes over time but with different choosing for the constant  $C$  to be 0.97. As you can notice, the proposed scheme outperforms the HEED protocol. The proposed protocol increased the network life-time for the LND metric by more than 100 rounds when the value of the constant  $C$  is 0.97. This improvement is due to the operation of rotating the CH within the same cluster which decrease the energy consumption and increase the network life-span. Rotation of the CH role within the same cluster instead of conducting a new clustering process as in the original HEED allows the energy consumed during the clustering phase to be saved and as consequently improving the network life-time.

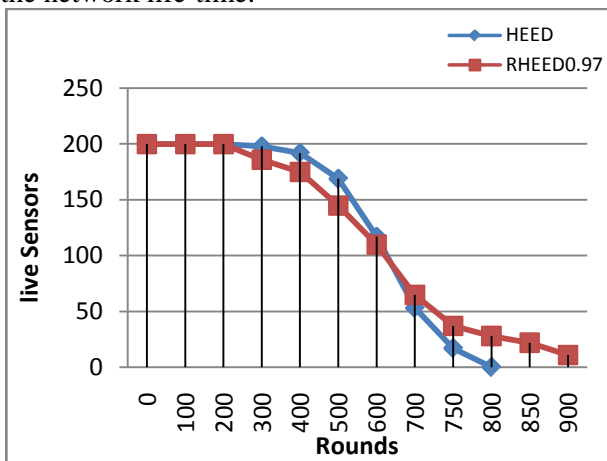

Fig.7. The comparison of the number of Alive sensors in HEED and RHEED with a constant value of 0.97.

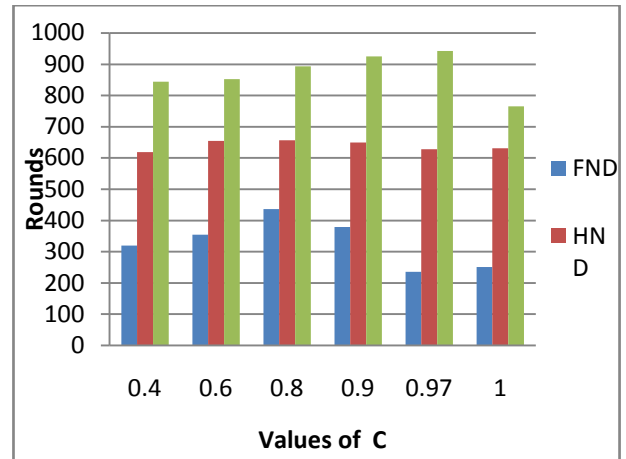

Fig.8. Fig.4.3: RHEED with Different Values of C.

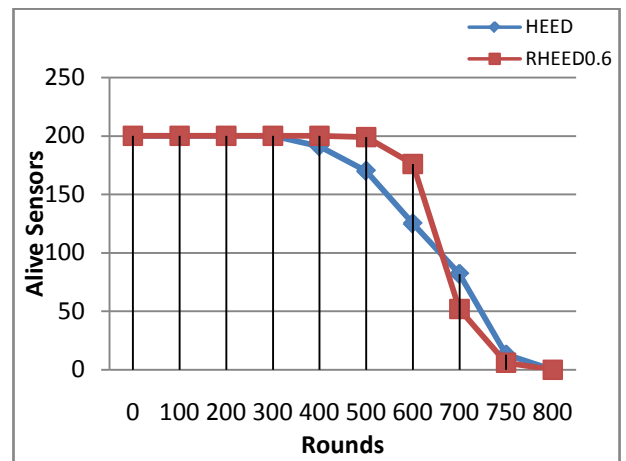

Fig.9. The comparison of HEED and RHEED with random distribution

In Fig. 7 we demonstrate how RHEED behave in term of the First Node Dies (FND), Half Nodes Die (HND) and the Last Node Dies (LND) with different values of the constant  $C$ . the constant value of 1 means that the clustering process will be conducted at every round as it exactly in HEED. The fig. shows that for the first node dies metric, the best choice for  $C$  is the value 0.8 while the best choice for the constant  $C$  when the LND metric used is the value 0.97. For the HND metric the best choice also occurs when the constant  $C$  equals 0.8.

We also compare between both schemas using the same parameters stated in table except that we have deployed the nodes randomly to see the effect of the random distribution on the results. In this scenario, we have put the constant  $c$  equal to 0.6. We show the results of this comparison in Fig. 8 the results show also that our proposed scheme performs better than HEED especially in the earlier rounds of simulation.

#### 4.4.2 Multi-hop RHEED vs. Multi-hop HEED

In this subsection we compare multi-hop HEED clustering protocol with multi-hop RHEED. Multi-

hop in this context means that the cluster heads do not communicate directly with the base station. They instead find their multi-hop path to the BS using a specific routing protocol (for example: DSR) and then use this path to send their aggregated data on to the BS. Before that, we should fig. out which is the most suitable routing protocol; DSR, DCR or PEGASIS, to be used for inter-cluster routing in HEED or RHEED. Fig.10 presents a comparison between HDSR, HDCR and HPEGASIS while Fig.11 presents a comparison between RDSR, RDCR and RPEGASIS. The first letter in the names of the protocols refers to the name of the clustering scheme used; H for HEED and R for RHEED, while the remaining letters refer to the name of the routing protocol that have been used for inter-cluster routing. The number on the right side of protocol name refers to the value of the constant C. For example, RDSR0.5, this means that the clustering scheme is RHEED, the multi-hop routing protocol used is DSR and the value of the constant C is 0.5.

Form both figs. we could observe that DSR and DCR show close behavior while they perform better than PEGASIS when they are used for inter-cluster routing. This is due to that PEGASIS construct one long chain for all CHs within the WSN. This long chain results in a multi-hop path which contains more hops than supposed, for some CHs, which in turn consume more energy and as a results shorten the network life-time. Another reason for the poor performance of PEGASIS protocol that it needs to know the farthest CH from the BS which require that every CH should communicate with the BS to determine the farthest CH at the beginning of each round. In fact, this communications among the sink and CHs will consume an extra energy which also will shorten the network life-time.

In Fig.12 we present the results of the comparison between the multi-hop HEED and our proposed multi-hop scheme RHEED in term of sensor alive over time. We used the DSR routing protocol as inter-cluster routing protocol for both scheme in this comparison. We have varied the values of the constant C in our scheme between 0.5, 0.8 and 0.97. Form the fig., it can be noticed that different choosing for the constant C value affect the network life-time in a different way. When the constant value of C is 0.97 the proposed scheme outperforms than HEED in the later rounds of simulation while it defeats HEED in most rounds of simulation when the constant value is equal to 0.5 or 0.8 especially in the earlier rounds. This fact also holds even if we used another protocol for the inter-cluster communication, PEGASIS, as depicted Fig. 13 consequently

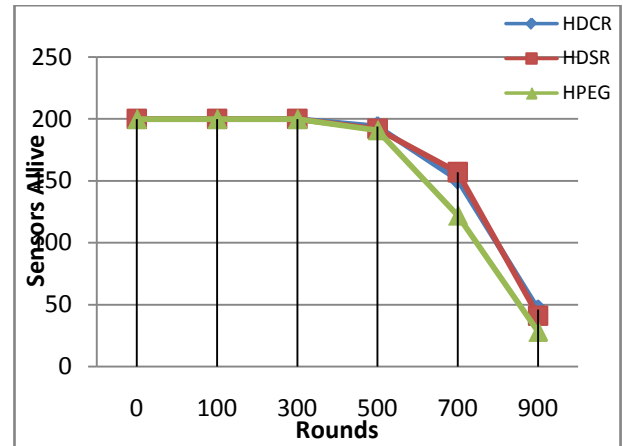

Fig.10. Number of alive sensors vs. number of rounds for HDCR, HDSR and HPEGASIS.

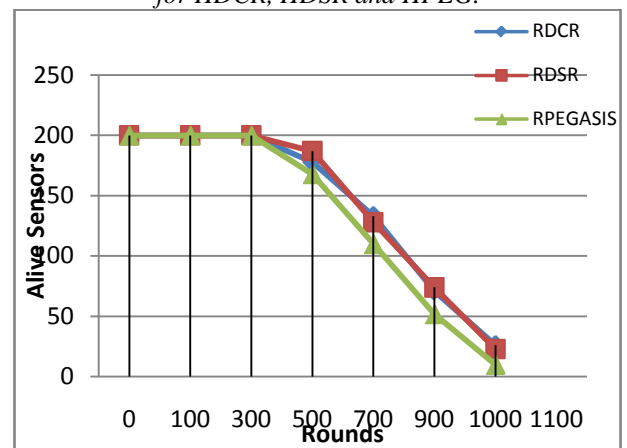

Fig.11. Number of live sensors vs. number of rounds for RDCR, RDSR and RPEGASIS.

Thus, for the application that requires that each sensor should work, we should choose C value to be suitable enough for improving the network life-time until the first node dies. If the requirement of the application is to increase the life-time of the network until the last node dies, then the values of the constant C between 0.9 and 1 will be preferable because they improve the time until last node dies significantly.

We also evaluate how increasing number of the nodes could effect on both schemes; multi-hop HEED and multi-hop RHEED. The inter-cluster routing protocol used in these experiments is DSR. Fig.14 compares the life-time of the network with HEED to RHEED, where the network life-time is the time until the first node die and when the number of nodes is varied between 150, 200, 250, 300 and 350 nodes. Similar comparisons are conducted for the number of rounds until half nodes die and for the number of rounds until the last node dies as depicted in Fig.15 and Fig.16 consequently. Both protocols improve the network life-time when the number of nodes increases. The figs. show that, in almost all cases, multi-hop RHEED performs

better than multi-hop HEED. This improvement is also due to the operation of rotating the cluster head within the same group (cluster). This leads to minimizing the energy consumption and increasing the network life-span.

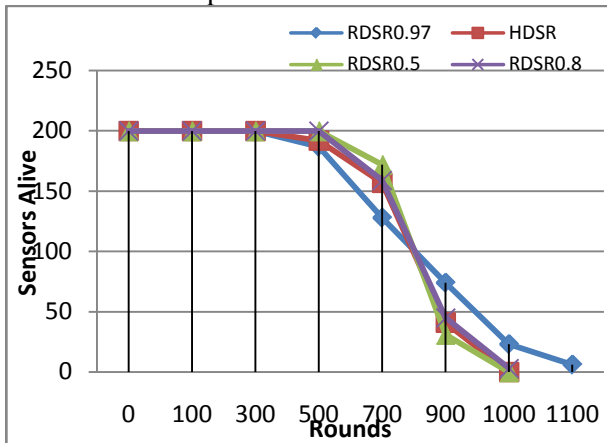

Fig.12. Alive sensors vs. number of rounds for multi-hop HEED and multi-hop RHEED using DSR.

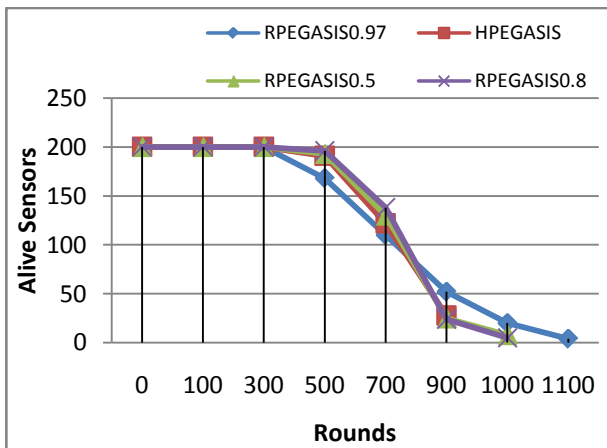

Fig.13. Live sensors vs. number of rounds for multi-hop HEED and multi-hop RHEED using PEGASIS.

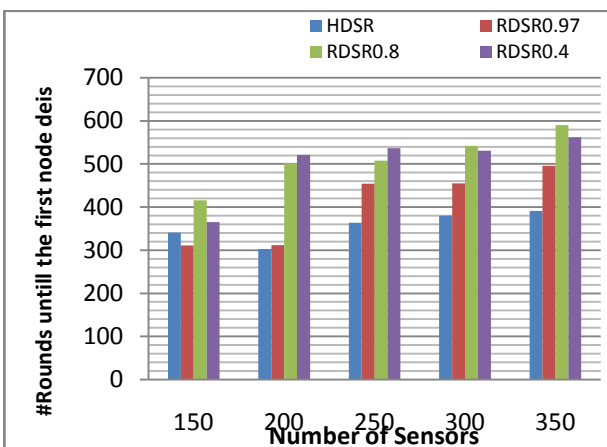

Fig.14. Comparing HEED and RHEED using different number of nodes for FND metric

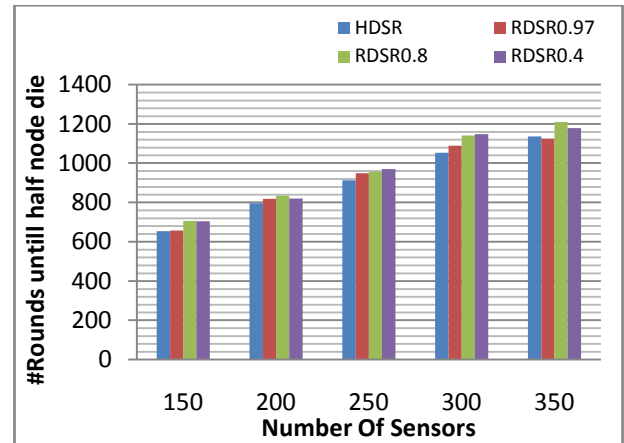

Fig.15. Comparing HEED and RHEED using different number of nodes for HND metric.

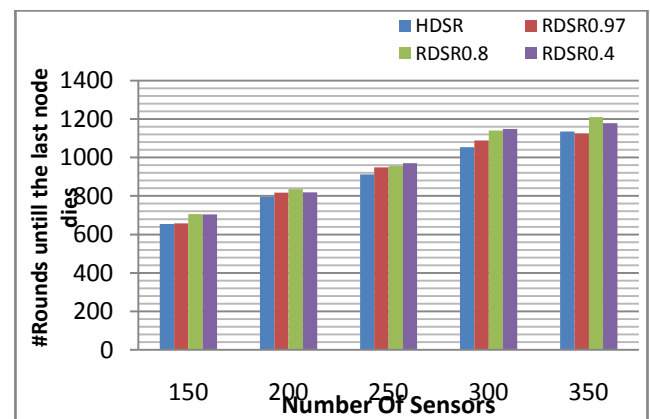

Fig.16. Comparing HEED and RHEED using different number of nodes for LND metric.

It can be easily observed from the figs. also that when the number of the nodes increases the percentage of improvement increase too. This could be justified as, when increasing number of the nodes, the amount of energy consumed during the clustering phase increases. Thus, the energy saved as a result of our powerful clustering scheme will be maximized which in turn will lead to improving the network life-time.

## 5 Conclusions and Future Work

In this paper, we proposed a clustering scheme for wireless sensor networks that appeared to be more energy-efficient than HEED in most cases. The protocol main contribution is to rotate the role of the CH between nodes in the same group until the residual energy of at least one cluster head fall below a specific threshold. We compared and evaluate the proposed protocol performance with the well-known clustering protocol (HEED) in terms of network lifetime, and energy consumption.

Simulation results show that the proposed algorithm performs better than HEED. The



percentage of improvement depends on the best choice of the constant C, the evaluation metric used and the characteristic of wireless sensor network. This improvement is due to that the proposed algorithm does not perform clustering at each round, it only perform it occasionally when the residual energy of at least one CH goes under a specific threshold. In addition to the proposed scheme, we also conduct a performance evaluation of using three different routing protocols for inter-cluster routing in our proposed schema and HEED. The three routing protocol compared here are DSR, DCR and PEGASIS. The simulation experiments show that using DSR or DCR for inter-cluster routing has the same impact on the energy consumption. The experiments also show that using PEGASIS for inter-cluster routing is poor choice because it consumes more energy than DCR and DSR and consequently shorten the network life-span. The poor performance of PEGASIS is due to that it constructs one long chain for CHs nodes in the network. This long chain results in a multi-hop path which contains more hops than supposed which in turn consume more energy and as a results shorten the network life-time. Another reason for the poor performance of PEGASIS protocol is the extra communications between the CHs and the BS required to determine the farthest CH from the BS.

During the time we have been working on this study, some ideas and questions regarding the subject arose to us. Here we outlined and presented some of these ideas to be pursued in order to improve our work.

The rotating of the cluster heads in our scheme was completely random. We think that using more controlled approach that takes in its consideration different parameters and conditions such as residual energy, received signal strength and the locations of the nodes is a good idea to be investigated.

The data aggregation of our proposed schema, like in HEED, is developed under the assumption that the close nodes sense similar data and as consequently there is a high data-correlation. For scenarios where there is not a correlation between the gathered data, aggregating the data into a single packet at the cluster head is not suitable. Thus, studying suitability of our proposed scheme under these scenarios is another good idea for future work.

In our implementation for PEGASIS as inter-cluster routing protocol, we have adopted a chain leader selection strategy in which the last node added to the chain was selected as a chain leader. Studying the effect of using other strategies for selection the chain leader is another good research area.

Finally, the performance metrics used in evaluation of the protocols were limited to the energy consumption. We propose for future work to evaluate the performance of our proposed scheme with other metrics such as packet delivery ratio and end-to-end delay.

### References

- [1] Akkaya, K., &Younis, M. (2005). A survey on routing protocols for wireless sensor networks. *Ad hoc networks*, 3(3), 325-349.
- [2] Abbasi, A. A., &Younis, M. (2007). A survey on clustering algorithms for wireless sensor networks. *Computer communications*, 30(14), 2826-2841.
- [3] Ahmed, B., Islam, M. K. B., &Rahman, J. (2011). Simulation, Analysis and Performance Comparison among different Routing Protocols for Wireless Sensor Network. *Computer Engineering and Intelligent Systems*, 2(4), 61-71.
- [4] Akyildiz, I. F., Su, W., Sankarasubramaniam, Y., &Cayirci, E. (2002). Wireless sensor networks: a survey. *Computer networks*, 38(4), 393-422.
- [5] Ali, M. S., Dey, T., &Biswas, R. (2008, December). ALEACH: Advanced LEACH routing protocol for wireless microsensor networks. In *Electrical and Computer Engineering, 2008.ICECE 2008. International Conference on* (pp. 909-914). IEEE.
- [6] Al-Karaki, J. N., & Kamal, A. E. (2004). Routing techniques in wireless sensor networks: a survey. *Wireless Communications, IEEE*, 11(6), 6-28.
- [7] Cerpa, A., Elson, J., Estrin, D., Girod, L., Hamilton, M., & Zhao, J. (2001). Habitat monitoring: Application driver for wireless communications technology. *ACM SIGCOMM Computer Communication Review*, 31(2 supplement), 20-41.
- [8] Eleburuik, I, &Adekunle. S., (2010). An Energy Efficient Protocol Based on Hierarchical Routing Technique for WSN. (Master thesis, Blekinge Institute of Technology). Retrieved from [http://www.bth.se/fou/cuppsats.nsf/all/6b6f6b72800ae835c1257749004a55a8/\\$file/Final%20Report\\_Report-Ismail%26Simeon.pdf](http://www.bth.se/fou/cuppsats.nsf/all/6b6f6b72800ae835c1257749004a55a8/$file/Final%20Report_Report-Ismail%26Simeon.pdf)
- [9] Heinzelman, W. R., Chandrakasan, A., & Balakrishnan, H. (2000, January). Energy-efficient communication protocol for wireless microsensor networks. In *System Sciences, 2000.Proceedings of the 33rd Annual Hawaii International Conference on* (pp. 10-pp). IEEE.
- [10] Ilyas, M., &Mahgoub, I. (2004). Performance and Design Aspects. *Handbook of sensor networks: compact wireless and wired sensing systems*. Boca Raton, Florida, USA. CRC Press.
- [11] Islam, K. (2010). Energy aware techniques for certain problems in Wireless Sensor Networks (Doctoral dissertation, Queen's University).
- [12] Karl, H., &Willig, A. (2007). *Protocols and*

architectures for wireless sensor networks. Wiley.com.

- [13] Krishnamachari, L., Estrin, D., & Wicker, S. (2002). The impact of data aggregation in wireless sensor networks. In *Distributed Computing Systems Workshops, 2002. Proceedings. 22nd International Conference on* (pp. 575-578). IEEE.
- [14] Lindsey, S., & Raghavendra, C. S. (2002). PEGASIS: Power-efficient gathering in sensor information systems. In *Aerospace conference proceedings, 2002. IEEE (Vol. 3, pp. 3-1125)*. IEEE.
- [15] Liu, G., Xu, B., & Chen, H. (2012). Decentralized estimation over noisy channels in cluster-based wireless sensor networks. *International Journal of Communication Systems*, 25(10), 1313-1329.
- [16] Liu, W., Sun, Y., Bai, Y., Yu, J., & Cao, B. (2009, February). DCR: An Energy-Efficient Distributed Clustering and Routing Protocol for Wireless Sensor Networks. In *Communication Software and Networks, 2009. ICCSN'09. International Conference on* (pp. 786-790). IEEE.
- [17] Madani, S. A., Hayat, K., & Khan, S. U. (2012). Clustering-based power-controlled routing for mobile wireless sensor networks. *International Journal of Communication Systems*, 25(4), 529-542.
- [18] Mainland, G., Parkes, D. C., & Welsh, M. (2005, May). Decentralized, adaptive resource allocation for sensor networks. In *Proceedings of the 2nd conference on Symposium on Networked Systems Design & Implementation-Volume 2* (pp. 315-328). USENIX Association.
- [19] Naghibzadeh, M., & Yaghmaee Moghaddam, M. H. (2011, February). A Hybrid Clustering Approach for Prolonging lifetime in wireless sensor networks. In *2011 international symposium on computer networks and distributed systems*.
- [20] Peiravi, A., Mashhadi, H. R., & Hamedjavadi, S. (2013). An optimal energy-efficient clustering method in wireless sensor networks using multi-objective genetic algorithm. *International Journal of Communication Systems*, 26(1), 114-126.
- [21] Perkins, C. E., Royer, E. M., Das, S. R., & Marina, M. K. (2001). Performance comparison of two on-demand routing protocols for ad hoc networks. *Personal Communications, IEEE*, 8(1), 16-28.
- [22] Pham, N. D., Le, T. D., Park, K., & Choo, H. (2010). SCCS: Spatiotemporal clustering and compressing schemes for efficient data collection applications in WSNs. *International Journal of Communication Systems*, 23(11), 1311-1333.
- [23] Postech Pohang University of Science and Technology. Mobile Networking Laboratory. Retrieved June 4, 2012, from <http://monet.postech.ac.kr/research.html>.
- [24] Saini, D. S., Dubey, C., Rathor, S., & Sisodia, R. (2009, August). Implementation and comparison of clustering techniques in wireless routing protocols. In *Computer Science and Information Technology, 2009. ICCSIT 2009. 2nd IEEE International Conference on* (pp. 159-162). IEEE.
- [25] Vasanthi, V., Nagarajan, P., Bharathi, B., & Hemalatha, M. A. (2010). Perspective Analysis of routing protocols in wireless sensor network. *International Journal on Computer Science and Engineering*, 2(8), 2511-2518.
- [26] Wang, X., & Qian, H. (2012). Hierarchical and low-power IPv6 address configuration for wireless sensor networks. *International Journal of Communication Systems*, 25(12), 1513-1529.
- [27] Wei Z, Hui-min C, Xue-fan Z. (2007). An energy efficient strong head clustering algorithm for wireless sensor networks. *Wireless Communications, Networking and Mobile Computing, 2007. Shanghai*, 2(58), 4-7.
- [28] Wei, D., Jin, Y., Vural, S., Moessner, K., & Tafazolli, R. (2011). An energy-efficient clustering solution for wireless sensor networks. *Wireless Communications, IEEE Transactions on*, 10(11), 3973-3983.
- [29] Xu, K., & Gerla, M. (2002, October). A heterogeneous routing protocol based on a new stable clustering scheme. In *MILCOM 2002. Proceedings (Vol. 2, pp. 838-843)*. IEEE.
- [30] Younis, O., & Fahmy, S. (2004). HEED: a hybrid, energy-efficient, distributed clustering approach for ad hoc sensor networks. *Mobile Computing, IEEE Transactions on*, 3(4), 366-379.
- Zhao, F., Shin, J., & Reich, J. (2002). Information-driven dynamic sensor collaboration. *Signal Processing Magazine, IEEE*, 19(2), 61-72.