

# A Hybrid Noise Cancelling Algorithm with Secondary Path Estimation

EDGAR LOPEZ-CAUDANA<sup>1</sup>, PABLO BETANCOURT<sup>1</sup>, ENRIQUE CRUZ<sup>1</sup>,  
MARIKO NAKANO-MIYATAKE<sup>2</sup>, HECTOR PEREZ-MEANA<sup>2</sup>

1. DIEM DIA, Tecnológico de Monterrey CCM  
Calle del Puente 222, CP16034, Mexico D.F.  
Mexico

edlopez@itesm.mx

2. Mechanical and Electrical Engineering School  
National Polytechnic Institute  
Av. Santa Ana 1000, 04030 Mexico D.F.  
MEXICO

hmpm@prodigy.net.mx <http://calmecac.esimecu.ipn.mx>

**Abstract:** - This paper presents a hybrid active noise canceling (HANC) algorithm to overcome the acoustic feedback present in most ANC system, together with an efficient secondary path estimation scheme. The HANC system provides a solution of two fundamental problems present in these kind of ANC systems: The first consists in a reduction of the acoustic feedback from the cancellation loudspeaker to the input microphone, using two FIR adaptive filters, one with a feedforward configuration and the other with a feedback adaptive filter configuration. To overcome the secondary path modeling problem, a modification of the method proposed by Akhtar is used. Computer simulation results are provided to show the noise cancellation and secondary path estimation performance of presented scheme.

**Key-Words:** - Active noise canceling, secondary path estimation, feed-forward ANC, feedback ANC, FxLMS, hybrid structure, Akhtar method.

## 1 Introduction

The need to eliminate unwanted noise is greater, as it is an expression of the limited tolerance that we have as individuals to the perception of sounds generated by industrial equipment, appliances and some general properties that are unpleasant for most people. Generators are just a few examples of processes or equipments that produce signals nuisance to human ear. Mechanical vibrations produced by engines in operation, digging machinery and electricity. While methods for mitigating these unwanted sounds already have been proposed, most of them based on passive elements, they offer a poor response to low frequency sounds. This drawback happens [1], when the wavelength of the signal is long compared to the size of the muffler liabilities. The relevance in the treatment of low-frequency sounds is that they produce fatigue and loss of concentration, thus affecting the people performance, machinery and equipment present. That is because low-frequency sounds produce very intense vibrations that can fracture structures during very long periods of exposure.

An adaptive filter responds to changes in its parameters, like for example: its resonance frequency, input signal or transfer function that varies with time. This behavior is possible due to the adaptive filter coefficients vary over time and are updated automatically by an adaptive algorithm.

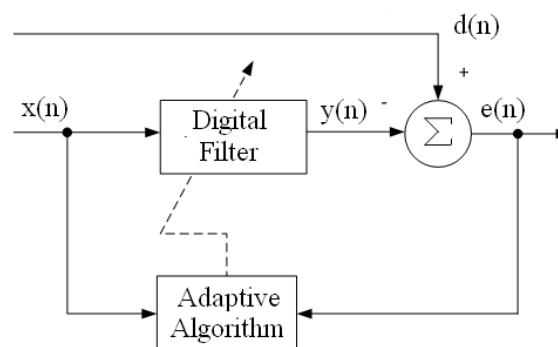

Fig. 1 Adaptive System

Therefore, these filters can be used in applications where the input signal is unknown or not necessarily stationary. An adaptive filter is made up of two parts: a digital filter and an adaptive algorithm. The block diagram of an adaptive filter is shown in Fig. 1, we can see that the adaptive algorithm needs two input signals,  $x(n)$  and  $e(n)$  as its references to set the parameters of the digital filter and update its coefficients.

On other hand, the ANC Systems must respond to time environment and varying frequency characteristics of the primary noise which must be tracked to get an acceptable noise cancellation performance:

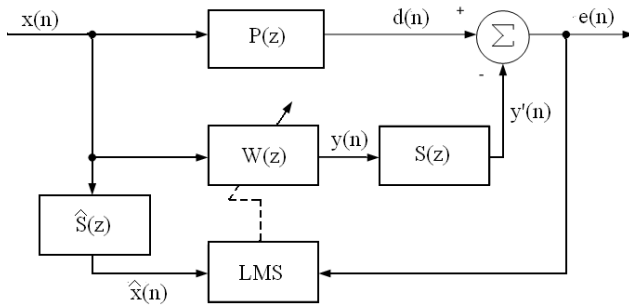

Fig. 2 Feedforward ANC System with FXLMS Algorithm

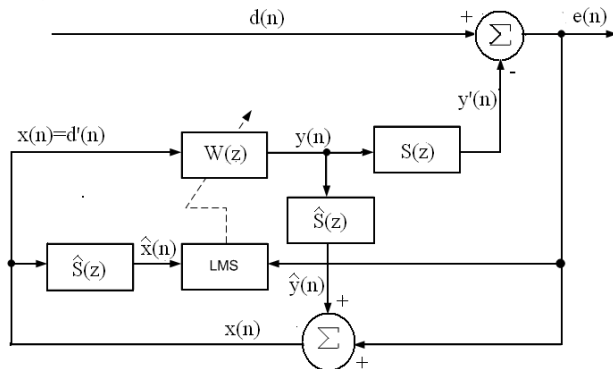

Fig. 3 Feedback ANC System with FXLMS Algorithm

Consider the ANC shown in Figs. 2 and 3 which are similar to the well known adaptive noise canceling proposed by Widrow and Stearns [2], although there are two important differences. Firstly in an ANC the cancellation process is carried out in the acoustic domain, while in adaptive noise canceling it is carried out in the electrical domain, doing it a more difficult task; and second the ANC output is filtered by a system  $S(z)$ , as shown in Figs. 2 and 3, which produces a delay of the filter output with respect to its input.  $S(z)$ , known as secondary path, which represent the effect of filters, A/D and D/A converters, loudspeakers, microphone and acoustic path between canceling loudspeaker and microphone must be estimated in order to avoid performance degradation.

Two configurations are widely used: the feedforward and feedback configurations, shown in Figs. 2 and 3 respectively, both of them with advantage and disadvantages depending on the noise signal and environment characteristics. The feedforward ANC structure is able to handle both, narrow band and wide band noise, however in many cases the canceling signal produced by the ANC also reach the input microphone. This fact produces significant performance degradation. On the other hand the feedback ANC structure does not present this kind of distortion because this structure does not use any input microphone, as shown in Fig 2. However, because this structure generates its own input signal though a linear prediction operation, its

performance degrades when the correlation among its samples weakens [3]. Because the feedforward ANC structure can be used to solve almost any noise cancelling problem, important efforts have been done to solve the feedback distortion problem [4]. Among them the hybrid structures which combine the properties of both realization forms appear to be a desirable alternative.

As mentioned before, the filter output signal  $y(n)$  reach the cancelling point to generate the output error,  $e(n)$ , through the so called secondary path,  $S(z)$ , which takes in consideration the digital to analog converter, reconstruction filters, the loudspeaker, amplifier, the acoustic from the loudspeaker to the microphone error, the error microphone, and analog to digital converter. Because the presence of  $S(z)$  causes that the input and the output error signals of adaptive algorithm be out of phase, to avoid distortion  $S(z)$  must be estimated in order that both, the filter output error and input signals be filtered by, in theory, the same system. There are two techniques for estimating the secondary path which are: offline and the online secondary path modeling. The first one is carried out using a Feedforward system where the plant now is  $S(z)$  and the coefficients of the adaptive filter are the estimated secondary path. This approach performs very well when  $S(z)$  is time invariant. However in practice this situation is seldom present in practice. When the secondary path is time varying, an online modeling approach must be used. Because an accurate estimation of  $S(z)$  is very important, several approaches have appear in the literature, among them the proposed by Eriksson [5], Bao [6], Zhang [6] and Akhtar [8], [9], in which a white noise sequence is used for  $S(z)$  estimation, are some of the more successful methods proposed in during the last several years.

This paper presents a hybrid structure which consists of a feedforward structure, used to estimate the noise path, and a feedback structure, used to cancel the feedback acoustic noise, as shown in Fig. 4. To avoid distortion due to the time varying conditions of  $S(z)$ , a secondary path estimation algorithm based on the Akhtar method [8], [9] is proposed.

This paper is organized as follows: In section 2 the general idea of a hybrid structure is described, together with some successful secondary path estimation methods. In section 3 the proposed structure is provided. Section 4 presents the evaluation results and finally the conclusions are provided in section 5.

## 2 Hybrid ANC Structures

Figure 4 shows the hybrid ANC structure output error is given by

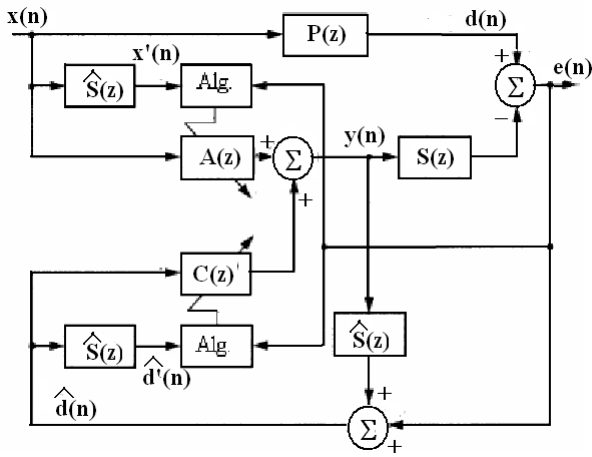

Fig. 4 Hybrid ANC structure

$$E(z) = (P(z) + (A(z)X(z) + D_s(z)C(z))S(z)) \quad (1)$$

where  $S(z)$  is the secondary path which is known in advance and then must be estimated from the input data; while  $A(z)$  and  $C(z)$  are the feed-forward and feedback sections which are updated using the FxLMS algorithm [1]. Because an accurate estimation of  $A(z)$  and  $C(z)$  highly depends on  $S(z)$  several algorithms have been proposed to it, some of them are describe in the next subsections

### 2.1 Modified Erickson Method

To analyze the behavior of a modified Erickson method for secondary path estimation, suitable for using in a hybrid ANC, consider the output error given by [5], [7], [10]

$$E(z) = D(z) + Y_s(z), \quad (2)$$

where

$$Y_s(z) = (Y(z) + R(z))S(z) \quad (3)$$

$$Y(z) = A(z)X(z) \quad (4)$$

and  $R(z) = X_p(z) - V(z)$ . Here  $v(n)$  is a white noise sequence. Thus, substituting (2)- (4) in (1) it follows that

$$E(z) = (P(z) + A(z)S(z))X(z) + S(z)R(z) \quad (5)$$

From (5) it follows that the noise  $S(z)R(z)$  is also present in the output error, and then the power of  $R(z)$  must be small to avoid distortion on the ANC output [9]. On the other hand, as  $S(z)R(z)$  increase respect to  $X(z)$ , the convergence factor should be smaller [9], [16].

Next consider the output error used to estimate  $S(z)$ , which from Fig. 5 is given by

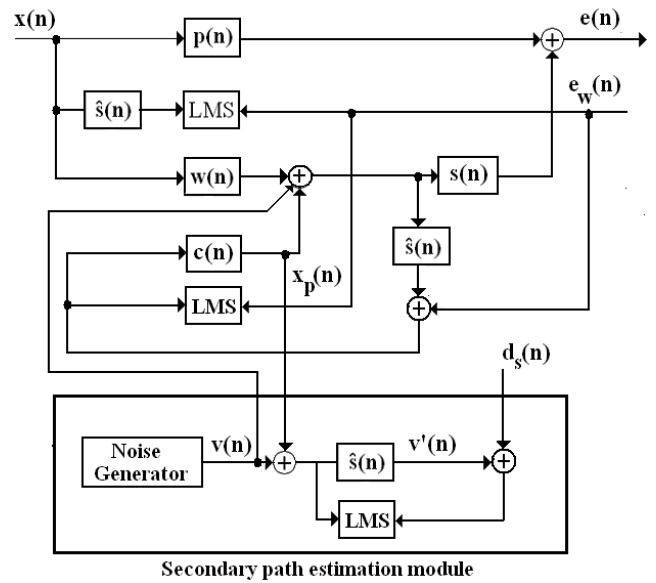

Fig. 5 Hybrid ANC with secondary path estimation using the Erickson method.

$$E_s(z) = E(z) - V'(z) \quad (6)$$

$$V(z) = \hat{S}(z)R(z) \quad (7)$$

$R(z) = X_p(z) + V(n)$  and  $V(n)$  is a white noise sequence. Substituting (5) and (7) in (6) we

$$E_s(z) = (P(z) + W(z)S(z))X(z) + (S(z) - \hat{S}(z))R(z) \quad (8)$$

From (8) it follows that the first term of the right side of this equation denotes the additive noise present during the secondary path estimation, which must be larger than  $R(z)$ . This fact do more difficult the secondary path estimation because, in this situation, the convergence factor must be very small to achieve the required performance [6], [7]. Here  $S(z)$  is updated using the LMS algorithm [2]. To solve this problem, which also degrades the noise path estimation,  $A(z)$ , several proposal have appeared in the literature. Some of them are described in the next subsections.

### 2.2 Modified Bao Method

One of the methods developed to overcome the problems present in the method proposed by Erickson is the Bao secondary that estimation method.

Consider the ANC output error,  $E(z)$ , shown in Fig. 3 which is given [11]

$$E(z) = D(z) + Y_s(z) \quad (9)$$

where

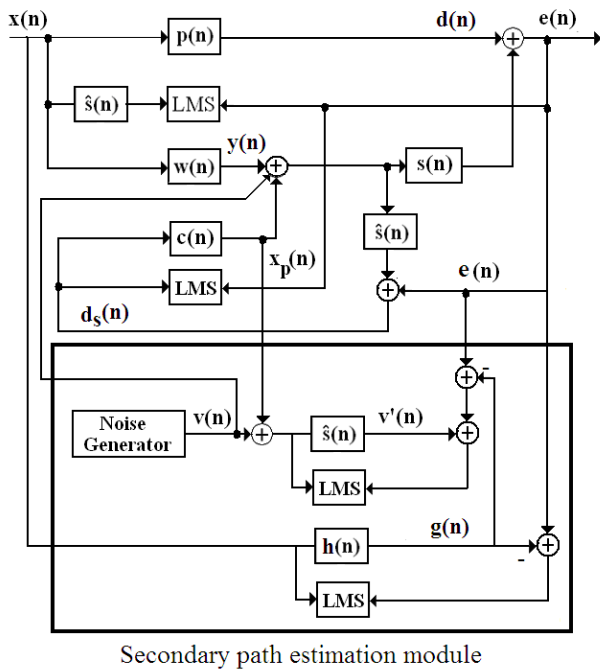

Fig. 6 Hybrid ANC with secondary path estimation using the Erickson method.

$$Y_s(z) = (Y(z) + R(z))S(z) \tag{10}$$

$$D(z) = P(z)X(z) \tag{11}$$

$$Y(z) = A(z)X(z) \tag{12}$$

and  $R(z)=X_p(z)+V(z)$ , where  $V(z)$  is a white noise sequence. Then substituting (10)-(12) in (11) it follows that

$$E(z) = (P(z) + A(z)S(z))X(z) + S(z)R(z) \tag{13}$$

From (13) it follows that the noise  $S(z)R(z)$ , is present in the output error and then the  $R(z)$  power must be small in order to avoid distortion at the system output. Thus as the power of  $S(z)R(z)$  becomes larger than  $X(z)$  the convergence factor must decrease. This condition is contradictory with the conditions required to estimate the secondary path, when a system identification configuration is used, as suggested by Erickson. To solve this problem consider  $E'(z)$  given by [5], [7]

$$E'(z) = E(z) - G(z) \tag{14}$$

where

$$G(z) = H(z)X(z) \tag{15}$$

Substituting (13) and (15) in (14) we get

$$E'(z) = (P(z) + W(z)S(z) - H(z))X(z) + S(z)R(z) \tag{16}$$

Next consider the output error  $E_s(z)$  which is given by [7]

$$E_s(z) = (P(z) + A(z)S(z) - H(z))X(z) + (S(z) - \hat{S}(z))R(z) \tag{17}$$

From (17) it follows that, if  $H(z)$  provides a good approach of  $P(z)+W(z)S(z)$ , the error  $E_s(z)$  used for estimating  $S(z)$  becomes

$$E_s(z) = (S(z) - \hat{S}(z))R(z) + \varepsilon(z) \tag{18}$$

where  $\varepsilon(z)$  is the residual error produced during the  $H(z)$  estimation. Thus if the additive noise used for  $S(z)$  estimation is reduced, the power of  $R(z)$  required will be lower than the power of  $R(z)$  required by the Erickson method, producing in this situation a less distortion at the ANC output  $E(z)$ . The adaptive filters used for secondary path estimation  $S(z)$  and  $H(z)$  are updated using the LMS algorithm. Figure 6 shows the block diagram of Bao estimation method.

### 2.3 Modified Zhang Method

Other approach used to solve some of the limitations existing in the Erickson method in the method proposed by Zhang [11].

Consider the output error  $E(z)$  given by

$$E(z) = D(z) + Y_s(z) \tag{19}$$

where

$$Y_s(z) = (Y(z) + R(z))S(z) \tag{20}$$

$$D(z) = P(z)X(z) \tag{21}$$

$$Y(z) = A(z)X(z) \tag{22}$$

$R(z)=X_p(z)+V(z)$ , and  $V(z)$  is a white noise sequence. Substituting (20)-(22) en (19) it follows that

$$E(z) = (P(z) + A(z)S(z))X(z) + S(z)R(z) \tag{23}$$

From (23) it follows that the noise  $S(z)R(z)$ , is present in the output error and  $R(z)$  should be small to not distort the output signal. Additionally as  $S(z)R(z)$  becomes larger than  $X(z)$  the convergence factor should be smaller. This is opposite to the conditions required for accurate secondary path estimation using system identification configuration. To avoid this problem, consider  $E'(z)$  which is given by

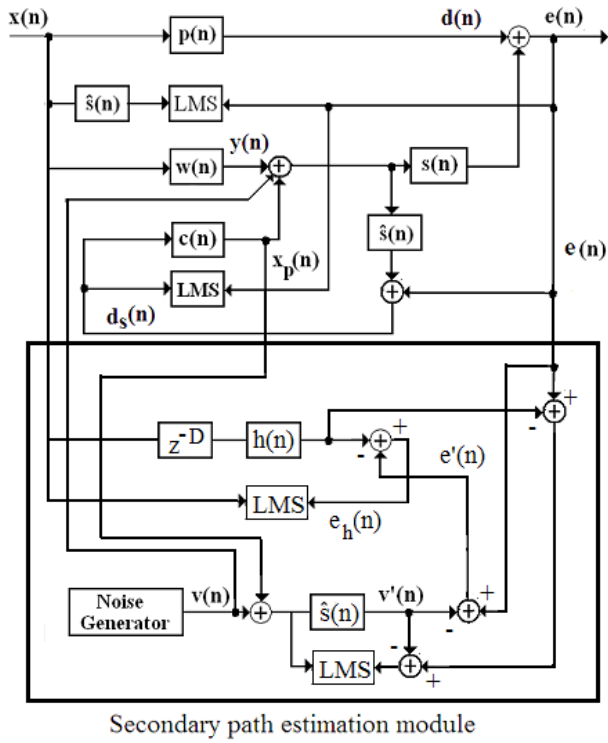

Fig. 7 Hybrid ANC with secondary path estimation using the Erickson method.

$$E'(z) = E(z) - \hat{V}(z) \quad (24)$$

$$\hat{V}(z) = \hat{S}(z)R(z) \quad (25)$$

Substituting (13) y (15) in (14) it follows that

$$E'(z) = (P(z) + W(z)S(z))X(z) + (S(z) - \hat{S}(z))R(z) \quad (26)$$

Next consider  $E_h(z)$  which is given by

$$E_h(z) = E'(z) - Y_h(z) \quad (27)$$

where

$$Y_h(z) = z^D H(z)X(z) \quad (28)$$

Substituting (26) and (28) in (27) it follows that

$$E_h(z) = (P(z) + A(z)S(z) - z^D H(z))X(z) + (S(z) - \hat{S}(z))R(z) \quad (29)$$

Equation (29) shows that the additive noise present in the estimation of  $H(z)$  is reduced as compared with Bao method, given by (16). Next consider the output error  $E_s(z)$  which is given by [5], [8]

$$E_s(z) = G(z) - \hat{V}(z) \quad (30)$$

where

$$G(z) = E(z) - Y_h(z) \quad (31)$$

Substituting (23) and (28) in (31) it follows that

$$G(z) = (P(z) + A(z)S(z) - z^D H(z))X(z) + S(z)R(z) \quad (32)$$

Finally substituting (25) y (32) in (30) get

$$E_s(z) = (P(z) + A(z)S(z) - z^D H(z))X(z) + (S(z) - \hat{S}(z))R(z) \quad (33)$$

From (33) it follows that if  $z^D H(z)$  provides a good estimation of  $P(z) + W(z)S(z)$ , the error  $E_s(z)$  used to estimate  $S(z)$  I approximately given by

$$E_s(z) = (S(z) - \hat{S}(z))R(z) + \varepsilon(z) \quad (34)$$

where  $\varepsilon(z)$  is the residual error produced by the estimation of  $z^D H(z)$  [8]. Thus because the additive noise used for estimation of  $S(z)$  can be reduced, the power  $R(z)$  may be smaller than the required by the Erickson method, resulting in a smaller distortion in the system output  $E(z)$ . Again the filters involved in the secondary path estimation are updated using the LMS algorithm. Figure 7 shows the block diagram of Zhang secondary path estimation method.

### 3. Proposed ANC Structure

Figure 8 shows the bock diagram of proposed hybrid ANC structure with online on-line secondary path modeling. Proposed hybrid ANC structure consists of a feedforward stage,  $W(z)$ , which is used to estimate the noise path,  $P(z)$ , and a predictive structure,  $M(z)$ , which is used to cancel the distortion due to the acoustic feedback path,  $F(z)$ . The main idea is that, because the samples of feedback distortion are strongly correlated among them, they can be predicted.

As shown in Fig. 8 the same signal,  $a(n)$ , is used as the error signal to update the adaptive filter,  $W(z)$ , which corresponds to the feedforward stage used to identify the noise path, as well as to update the linear predictive filter  $M(z)$ , which intends to cancel the distortion produced by the feedback propagation from the canceling loudspeaker to the input microphone through the system  $F(z)$ , as shown in Fig. 8; and to estimate  $\hat{S}(z)$  that represents the online secondary path modeling adaptive filter. From Fig. 8, we can see that the error signal of all the ANC system is given by:

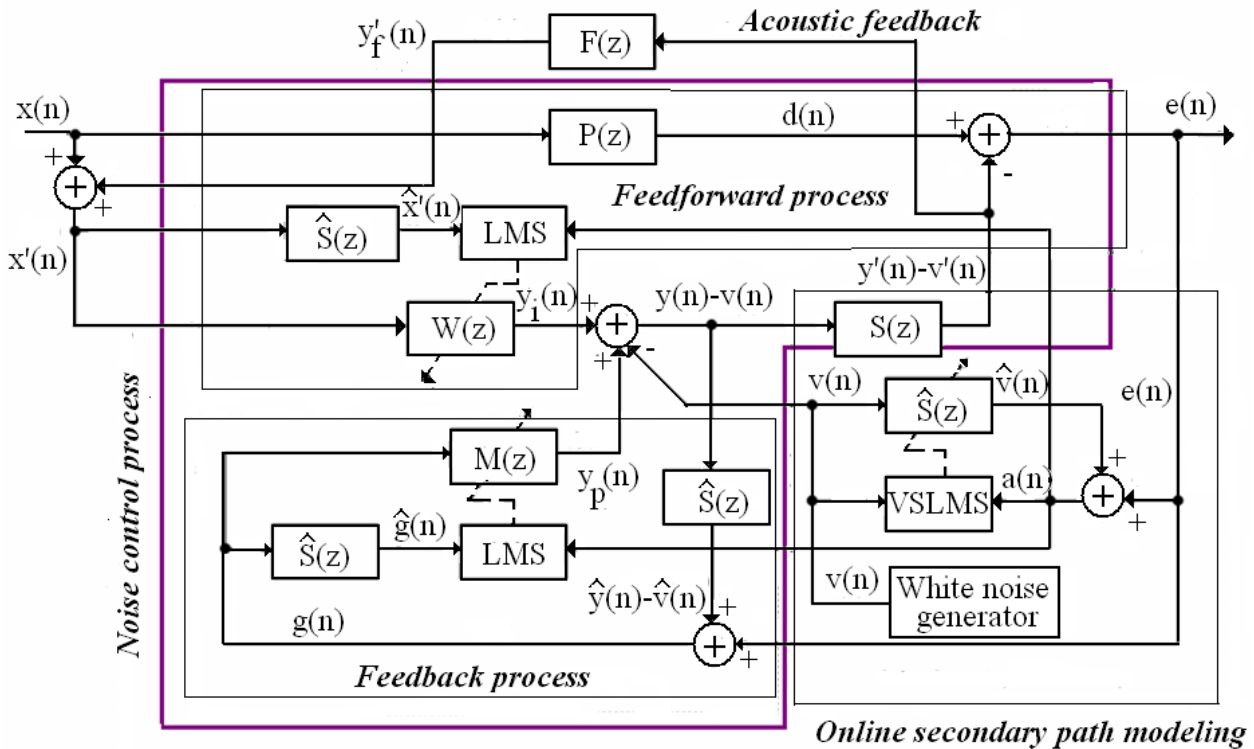

Fig. 8 Proposed hybrid ANC structure

$$e(n) = d(n) + [v(n) - y(n)] * s(n) \tag{35}$$

where  $d(n)$  is the desired response,  $v(n)$  is a white noise signal,  $s(n)$  is the finite impulse response of the secondary path and  $y(n)$  is the secondary path input signal used to produce the acoustic noise that achieves the attenuation of the primary noise. Thus from Fig. 8 it follows that

$$y(n) = y_i(n) + y_p(n) \tag{36}$$

$$y_i(n) = \bar{w}^T(n) \bar{x}'(n) \tag{37}$$

$$\bar{w}(n) \equiv [w_0(n), w_1(n), \dots, w_{L-1}(n)]^T, \tag{38}$$

$$\bar{x}'(n) \equiv [x'(n), x'(n-1), \dots, x'(n-L+1)]^T \tag{39}$$

$$x'(n) = x(n) + y'_f(n) - v'_f(n) \tag{40}$$

Here (40) denotes the reference signal that already considers the effects of the acoustic feedback. Thus taking in account the acoustic feedback consideration it follows that:

$$y'_f(n) = y'(n) * f(n) \tag{41}$$

$$v'_f(n) = v'(n) * f(n) \tag{42}$$

Both equations (41) and (42) contains  $f(n)$ , the finite

impulse response of the acoustic feedback filter; moreover  $y'(n)$  and  $v'(n)$  are the signals that have already been filtered by  $S(z)$ . Next consider the predictive stage whose output signal is given by

$$y_p(n) = \bar{m}^T(n) \bar{g}(n) \tag{43}$$

$$\bar{m}(n) \equiv [m_0(n), m_1(n), \dots, m_{M-1}(n)]^T \tag{44}$$

$$\bar{g}(n) \equiv [g(n), g(n-1), \dots, g(n-M+1)]^T \tag{45}$$

$$g(n) = e(n) + \hat{y}(n) - \hat{v}(n) \tag{46}$$

$$\hat{v}(n) = v(n) * \hat{s}(n) \tag{47}$$

$$\hat{y}(n) = y(n) * \hat{s}(n) \tag{48}$$

From (37) and (38) it follows that during the estimation of ANC coefficients vectors it is necessary to use the signals  $y(n)$  and  $v(n)$  once both of them already have been filtered by the estimated secondary path  $\hat{S}(z)$ . Thus an accurate estimation of  $\hat{S}(z)$  is required. To this end Akhtar method will be used.

The advantages of using the Akhtar's method [8], [9] for the secondary path modeling in proposed ANC system are reflected in the VSS-LMS algorithm [12], [13], that allows the modeling process to select initially a larger step size,  $\mu_s(n)$  which decreases to a minimum value according with the decreasing of  $[d(n) - y'(n)]$ . If the filter  $W(z)$  is slow in

reducing  $[d(n) - y'(n)]$ , then the step size may remain to small value for more time. Furthermore, the signal  $a(n) = e(n) - \hat{v}(n)$  is the same error signal use to update all the adaptive filters involved in the ANC system,  $W(z)$ ,  $M(z)$  and  $\hat{S}(z)$ . The reason to use this signal is that for  $W(z)$ ,  $[v'(n) - v(n)] < v'(n)$  compared with the Eriksson's method. So when  $\hat{S}(z)$  converges, that is

$$\hat{S}(z) \approx S(z), \tag{49}$$

ideally

$$v'(n) \approx v(n) \Rightarrow v'(n) - v(n) \rightarrow 0. \tag{50}$$

Thus, using the Akhtar method [8] for secondary path estimation, the proposed hybrid structure in updated as follows:

$$\begin{aligned} \bar{w}(n+1) = & \bar{w}(n) + \mu_w \bar{\hat{x}}(n)[d(n) - y'(n)] \\ & + \mu_w \bar{\hat{x}}(n)[v'(n) - \hat{v}(n)] \end{aligned} \tag{51}$$

$$\begin{aligned} \bar{m}(n+1) = & \bar{m}(n) + \mu_m \bar{\hat{g}}(n)[d(n) - y'(n)] \\ & + \mu_m \bar{\hat{g}}(n)[v'(n) - \hat{v}(n)] \end{aligned} \tag{52}$$

$$\begin{aligned} \bar{s}(n+1) = & \bar{s}(n) + \mu_s \bar{v}(n)[v'(n) - \hat{v}(n)] \\ & + \mu_s \bar{v}(n)[d(n) - y'(n)] \end{aligned} \tag{53}$$

Although (37) shows that when  $\hat{S}(z)$  converges, the whole control noise process of the system is not perturbed by the estimation process of  $\hat{S}(z)$ , it is significant to identify that the online secondary path modeling is degraded by the perturbation of  $\eta(n) = \mu_s \bar{v}(n)[d(n) - y'(n)]$ .

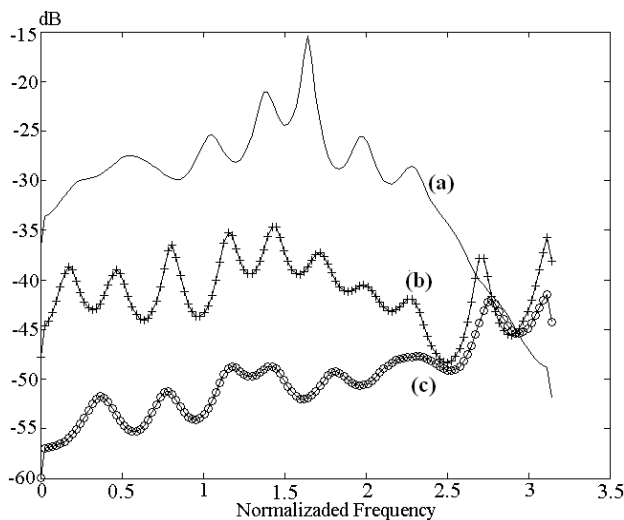

Fig.9 Power spectral density of (a) airplane noise, (b) power spectral density obtained using a feed-forward structure, (c) Power spectral density obtained using the hybrid structure.

#### 4. Computer Simulations

To evaluate the performance of hybrid noise cancelling together with the online secondary path estimation process, several computer simulations were carried out. Fig.9 shows the power spectrum of an airplane motor noise (a), the output error power spectrum obtained using a feed-forward system of order 40 (b) and the power spectrum of the output error obtained using the hybrid structure when it is required to identify an unknown acoustic path of order 40 (c). In both cases (b) and (c) the feedback acoustic path was of order 40.

Next, the evaluation of proposed system by computer simulation using synthetic as well as actual acoustic noise signals of the proposed secondary path estimation method is presented. The modeling error for secondary path estimation was defined as [14], [15]

$$\Delta S(dB) = 10 \log_{10} \left[ \frac{\sum_{i=0}^{M-1} [s_i(n) - \hat{s}_i(n)]^2}{\sum_{i=0}^{M-1} [s_i(n)]^2} \right] \tag{54}$$

An offline modeling was used to obtain FIR representations of tap weight length 20 for  $P(z)$  and of tap weight length 20 for  $S(z)$ . The control filter  $W(z)$  and the modeling filter  $\hat{S}(z)$  are FIR filters of tap weight length of  $L=20$  both of them. A null vector initializes the control filter  $W(z)$ . To initializes  $\hat{S}(z)$ , offline secondary path modeling is performed which is stopped when the modeling error has been reduced to -5dB. The step size parameters are adjusted by trial and error for fast and stable convergence [16], [17].

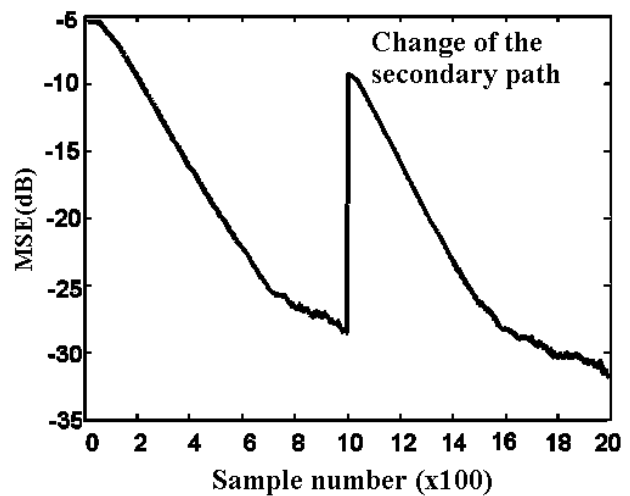

Fig.10 Convergence of performance of secondary path estimation algorithm when the noise to be cancelled is a sinusoidal signal. In iteration 1000 there is an abrupt change on  $S(z)$ .

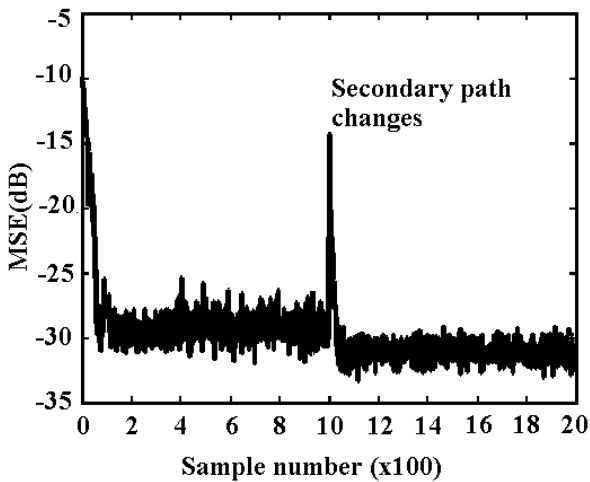

Fig.11 Convergence performance of proposed ANC when the noise to be cancelled is a sinusoidal signal. In iteration 1000 there is an abrupt change on  $S(z)$ .

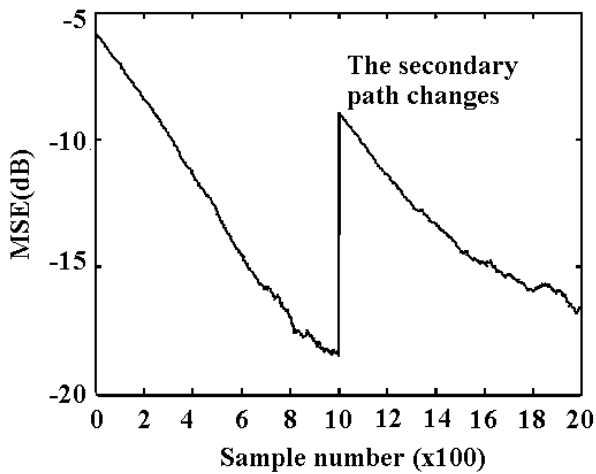

Fig. 12 Convergence performance of proposed ANC when the noise to be cancelled is a sinusoidal signal and the order is 32. In iteration 1000 there is an abrupt change on  $S(z)$ .

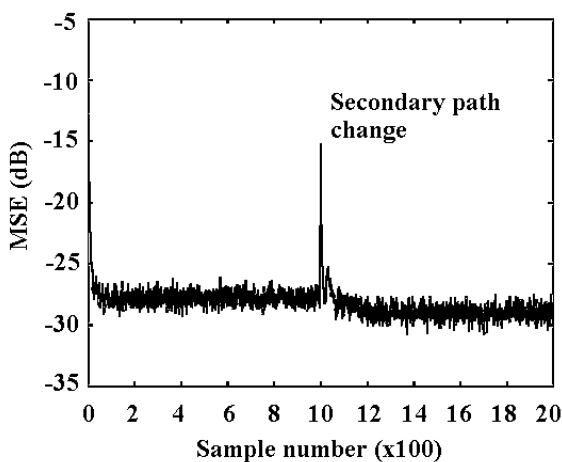

Fig. 13 Convergence performance of proposed ANC when the noise to be cancelled is a sinusoidal signal and the order is 32. In iteration 1000 there is an abrupt change on  $S(z)$ .

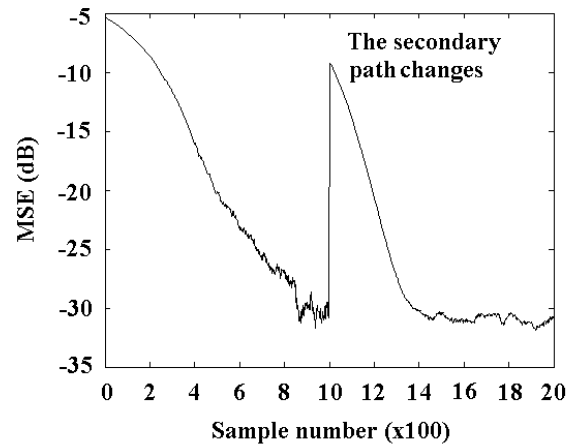

Fig.14 Convergence performance of secondary path estimation algorithm, when the noise to be cancelled is a narrow band noise. In iteration 1000 there is an abrupt change on  $S(z)$ .

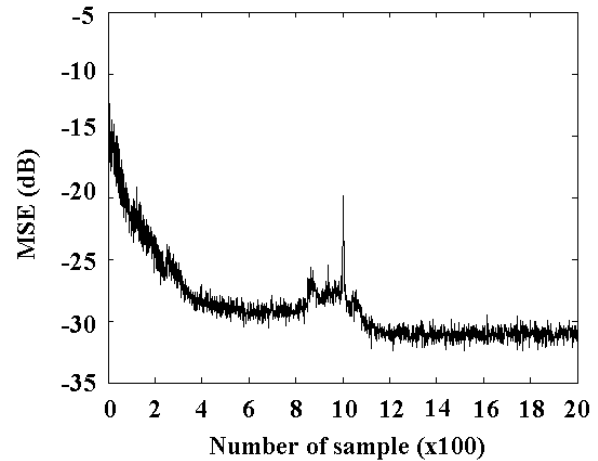

Fig.15 Convergence performance of proposed ANC when the noise to be cancelled is a narrow band noise. In iteration 1000 there is an abrupt change on  $S(z)$ .

Figure 10 shows the performance of proposed secondary path estimation algorithm, when the noise to be cancelled is a sinusoidal signal of 200 Hz. A zero mean uniform white noise is added with SNR of 20dB, and a zero mean uniform white noise of variance 0.005 is used in the modeling process. The corresponding curve for the cancellation process is shown in Fig. 11. The order of  $P(z)$ ,  $W(z)$  and  $S(z)$  and  $F(z)$  was in all cases equal to 20. Figs. 12 and 13 show the convergence performance of secondary path estimation and the noise cancellation performance of proposed system, respectively, when the noise to be cancelled is a sinusoidal signal. Here the order of  $P(z)$ ,  $W(z)$  and  $S(z)$  and  $F(z)$  was in all cases equal to 32.

Figures 14 and 15 show the convergence performance of proposed secondary path estimation and ANC algorithms, respectively, when it is required to cancel a narrow band noise signal that consists of 4 sinusoidal signals of frequencies 100, 200, 400, 600



Hz. A zero mean uniform white noise is added with SNR of 20dB, and a zero mean uniform white noise of variance 0.005 is used in the secondary path modeling process. Here in the iteration 1000 it is performed an abrupt change with the secondary path. The order of  $P(z)$ ,  $W(z)$  and  $S(z)$  and  $F(z)$  was in all cases equal to 20.

Figures 16 and 17 shows the secondary path estimation and noise cancellation performance, respectively, of proposed system when the order of  $P(z)$ ,  $W(z)$  and  $S(z)$  and  $F(z)$  was in all cases equal to 32 and the cancellation noise a narrow band random signal. Figures 18 and 19 shows the convergence performance of proposed structure when is required to cancel an actual noise motor signal (mixed band noise). A zero mean uniform white noise of variance 0.005 is used in the modeling process. In iteration 600 it is performed an abrupt change on the secondary path. The order of  $P(z)$ ,  $W(z)$  and  $S(z)$  and  $F(z)$  was in all cases equal to 20. Finally Figs. 20 and 21 show the convergence performance of proposed algorithm when it is required to cancel an actual motor noise signal. A zero mean uniform white noise of variance 0.005 is used in the modeling process. In iteration 600 it is performed an abrupt change on the secondary path  $S(z)$ . The order of  $P(z)$ ,  $W(z)$  and  $S(z)$  and  $F(z)$  was in all cases equal to 32.

Simulation results show that proposed ANC performs fairly well it is required to cancel both synthetic and actual noise signals. Evaluation results also show that proposed secondary path estimation algorithm also performs fairly well, providing an accurate secondary path,  $S(z)$ , estimation even if  $S(z)$  changes during the identification process.

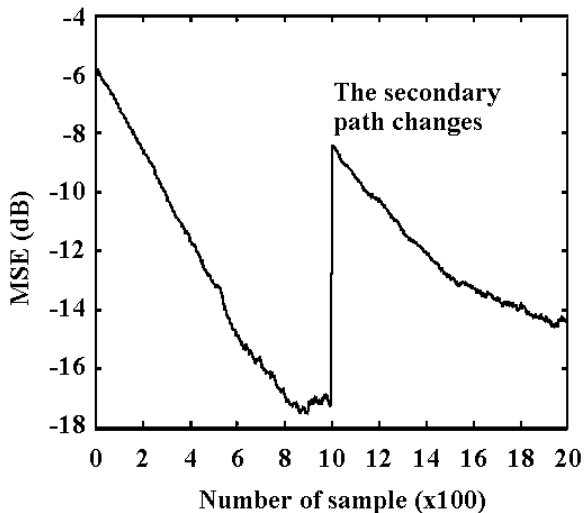

Fig.16 Convergence performance of secondary path estimation algorithm, when the noise to be cancelled is a narrow band noise with order 32. In iteration 1000 there is an abrupt change on  $S(z)$

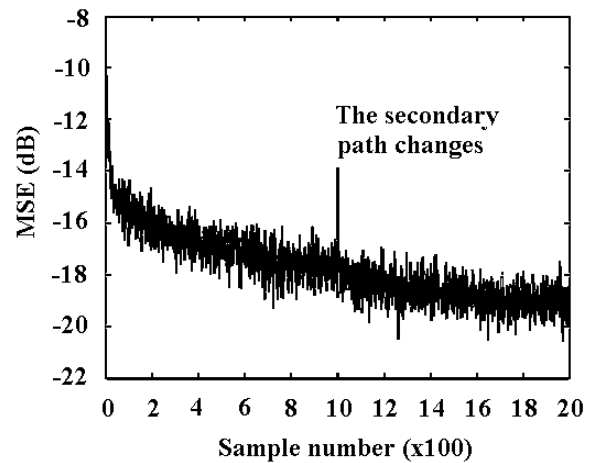

Fig.17 Convergence performance of proposed ANC when the noise to be cancelled is a narrow band noise and order 32. In iteration 1000 there is an abrupt change on  $S(z)$ .

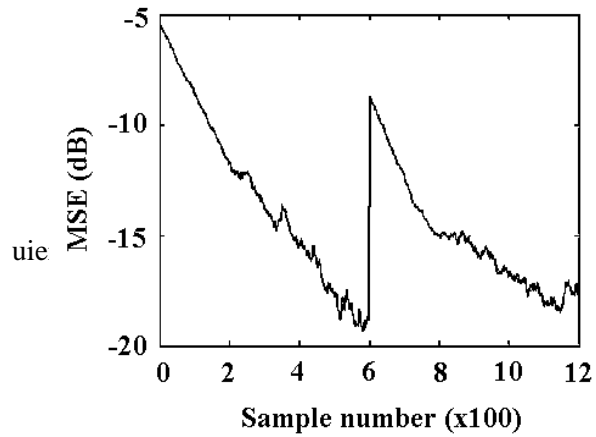

Fig.18 Convergence performance of secondary path estimation algorithm, when the noise to be cancelled is a motor noise signal. In iteration 600 there is an abrupt change on  $S(z)$ .

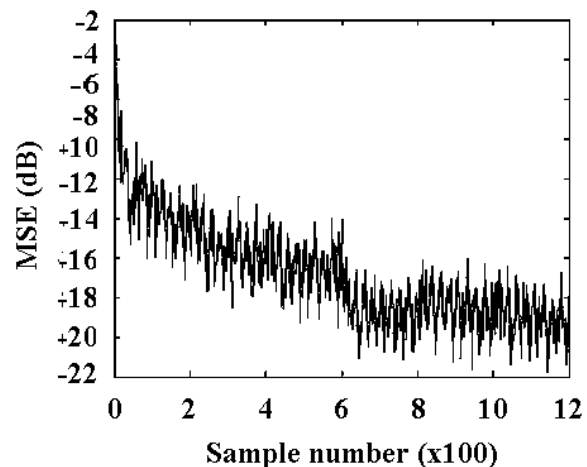

Fig.19 Convergence performance of proposed ANC when the noise to be cancelled is a motor noise signal. In iteration 600 there is an abrupt change on  $S(z)$ .

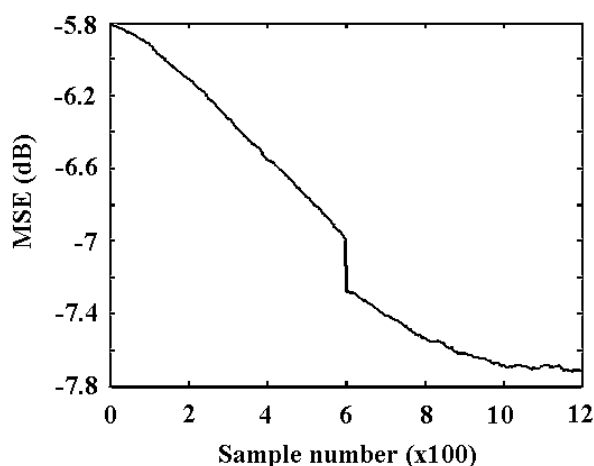

Fig.20 Convergence performance of secondary path estimation algorithm, when the noise to be cancelled is a motor noise signal and the order is 32.

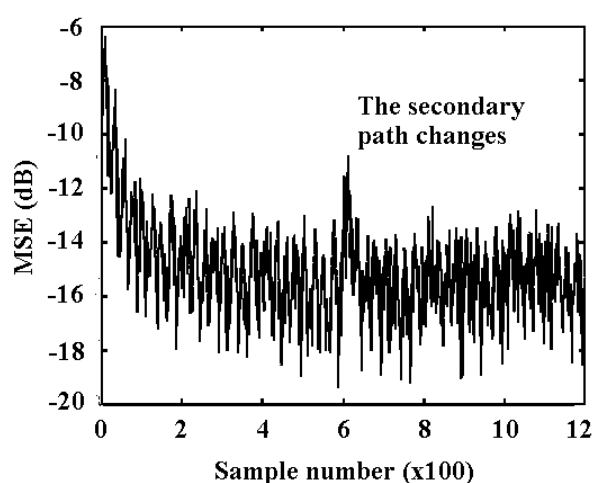

Fig.21 Convergence performance of proposed ANC when the noise to be cancelled is a motor noise signal and the order is 32. In iteration 600 there is an abrupt change on  $S(z)$ .

## 5. Conclusions

This paper proposed a hybrid ANC system that combines the feedforward and feedback structures, updated using the FxLMS, to improve the performance of ANC in presence of acoustic feedback distortion. Because reliable secondary path estimation is greatly important in the performance of any ANC system, proposed ANC also include a secondary path estimation algorithm which is able to carry out a reliable estimation even if it changes during the estimation process. Thus the use of a feedback section together with the online secondary path modeling allows the system to be adjustable for any kind of secondary path change (gradual ideally). Computer simulations show that proposed system provides an improved performance, at somewhat increased computational cost compare with the Akhtar's online secondary path method, but this method compensates the noise control process for the feedforward and feedback stages.

## References

- [1] S. M. Kuo, D. R. Morgan. *Active noise control systems: Algorithms and DSP Implementations* Wiley Series in Telecommunications and Signal Processing Editors, New York, 1996.
- [2] B. Widrow and S. Stearns, *Adaptive signal processing*, Prentice Hall, Englewood Cliffs, NJ, 1985.
- [3] D. Tapia Sánchez, R. Bustamante, H. Pérez Meana, M. Nakano Miyatake, Single Channel Active Noise Canceller Algorithm Using Discrete Cosine Transform, *Journal of Signal Processing*, Vol. 9, No. 2, 2005 pp. 141-151.
- [4] H. Pérez-Meana, M. Nakano-Miyatake, Active Noise Canceling: Structures and Adaptation Algorithms, *Advances in audio and Speech Signal Processing: Technologies and Applications*, Ed. H. Pérez-Meana, Idea Group Publishing, Hershey, 2007, pag. 286-308,.
- [5] L. J. Eriksson, M. C. Allie, y C. D. Bremigan, Active noise control using adaptive digital signal processing, *Proc. ICASSP*, 1988, pp. 2594-2597.
- [6] M. Zhang, H. Lan and W. Ser, *IEEE Trans on Speech and Audio Processing*, vol. 11 No. 1, 2003, pp. 45-53.
- [7] A. Romero, M. Nakano-Miyatake, H. Perez-Meana, A Hybrid Noise Canceling Structure with Secondary Path Estimation, *WSEAS Recent Advances in Systems, Communications and Computers*, 2008, pp.194-199.
- [8] M. T. Akhtar, M. Abe, and M. Kawamata, A Method for Online Secondary Path Modeling in Active Noise Control Systems, *Proc. of Int. Conf. on Circuits and Systems*, vol. 1, 2005, pp. 264-267.
- [9] M. Tahir Akhtar, M. Abe, and M. Kawamata, Modified-filtered-x LMS algorithm based active noise control system with improved online secondary-path modeling, *Proc. IEEE Int. Midwest Symp. on Circuits Systems*, vol. 1, 2004, 13-16.
- [10] L. J. Eriksson, and M. C. Allie, Use of random noise for on-line transducer modeling in an adaptive active attenuation system, *J. of Acoust. Soc. Am.*, vol. 85, No. 2, 1989, pp. 797-802..
- [11] M. Zhang, H. Lan, and W. Ser, On Comparison of Online Secondary Path Modeling Methods With Auxiliary Noise. *IEEE Transactions On Speech And Audio Processing*, Vol. 11, 2003, pp. 45-53.
- [12] M. Nakano, H. Perez, A Time Varying Step Size Normalized LMS Algorithm for Adaptive Echo Canceller Structure, *IEICE Trans. on Fundamentals of Electronics Computer Sciences*, Vol. E-78-A, 1995, pp. 254-258.
- [13] F. Casco, H. Perez, M. Nakano, M. Lopez, A Variable Step Size (VSS-CC) NLMS Algorithm,

*IEICE Trans Fundamentals of Electronics Computer Sciences*, Vol. E78-A, 1995, pp. 1004-1009.

- [14] A. D. Streeter, L. R. Jay and R. D. Collier, Hybrid Feedforward-feedback active noise control, *Proc. of the 2004 American Control Conference ACC*, June, 2004.
- [15] X. Kong, P. Liu and S. M. Kuo, Multiple channel hybrid active noise control systems, *IEEE Trans. On Control Systems Technology*, vol. 6 No 6, 1998, pp. 719-729.
- [16] E. Lopez-Caudana, P. Betancourt, E. Cruz, M. Nakano-Miyatake, H. Perez-Meana, A Hybrid Active Noise Cancelling with Secondary Path Modeling, *Proc. of IEEE Midwest Symposium on CAS*, 2008.
- [17] E. Lopez-Gaudana, P. Betancourt, E. Cruz, M. Nakano-Miyatake, H. Perez-Meana, "An Active Noise Cancelling Algorithm with Secondary Path Modeling", *12<sup>th</sup> WSEAS Int. Conf. on Computers*, July 23-25, Grecia, 2008.