

Active Power Influence on the Electrical Parameters of an Electro Thermal Installation with Electromagnetic Induction

CAIUS PANOIU*, RALUCA ROB*, MANUELA PANOIU*, GABRIEL POPA*

* Electrical Engineering and Industrial Informatics Department, Timisoara Polytechnic University, Faculty of Engineering Hunedoara, Revolutiei street, no 5, Hunedoara, cod 331115, Romania, { c.panoiu, raluca.rob, m.panoiu, g.popa}@fih.upt.ro

Abstract: - In this paper followed the variation of the electrical parameters that characterize the functioning of an electro thermal installation with electromagnetic induction. The measurements were made using a three phase power quality analyzer, CA 8334B. There were presented two different situations: the HF transformer with 5:1 and 3:1 transformation ratio. In order to recover the recordings, the transients, the alarms and the screen copies, there was used the QualiStar View software.

Key-Words: - Electro thermal installation, electrical parameters.

1. Introduction

Electromagnetic induction heating has a very wide spread applications in industry because the heating speed is higher then using another heating methods.

Electro thermal installations with electromagnetic induction contain supply sources that induce harmonic distortions in power distribution [6].

The frequency converters that are used in electro thermal installation sources lead to negative effects in the power distribution such as:

- distortion of the voltage waveform in power distribution;
- additional heating due to the rising of the current effective value;
- improper functioning of the protection relays [4]

These problems can generate a decreasing in productivity and a quality diminution in products or services, lead to high costs for industrial and commercial activities.

Electro thermal installation that is analyzed in this paper contains an inverter source supplied by a diode bridge rectifier.

2. Technical characteristics of the electro thermal installation

The measurement set was made during the functioning of an electro thermal installation with electromagnetic induction that is composed by a converter CTC100K15 and an inductor designed for hardening the materials. CTC100K15 has the following electric characteristics [1]:

- supplying voltage 3x400V, 50Hz;

- rated current 27A;
- control voltage 24Vdc;
- consumed power at high frequency 15kW;
- voltage at medium frequency 500Vac.

For supplying the hardening inductor, there are two high frequency toroidal transformers:

- T1: 660/500V, 40kVA, 70-100 kHz;
- T2: 150 kVA, 70-120 kHz with primary winding voltage of 500V and variable transformation ratio of 3:1, 5:1, 6:1, 10:1.

Figure 1 presents the simplified scheme of the electro thermal installation.

3. Measurement technique

3.1 General description

CA 8334B, a Chauvin Arnoux mark, is a three phase power quality analyzer [2] that can offer an instant image of a network principal characteristics and monitors the variation of the electrical parameters over a period of time or in transient mode. It can memorise the current screen and access screens already stored in the memory. The analyzer can represent the harmonic ratios of voltage, current and power and determine the harmonic current produced by non-linear loads.

The electrical parameters can be computed and represented as bar charts or curves on a LCD color screen. The measurements results can be printed on an external printer and data can be transfered in bidirectional mode to a personal computer using the RS232 serial interface.

CA 8334B can measure and compute the following electrical parameters: electrical network

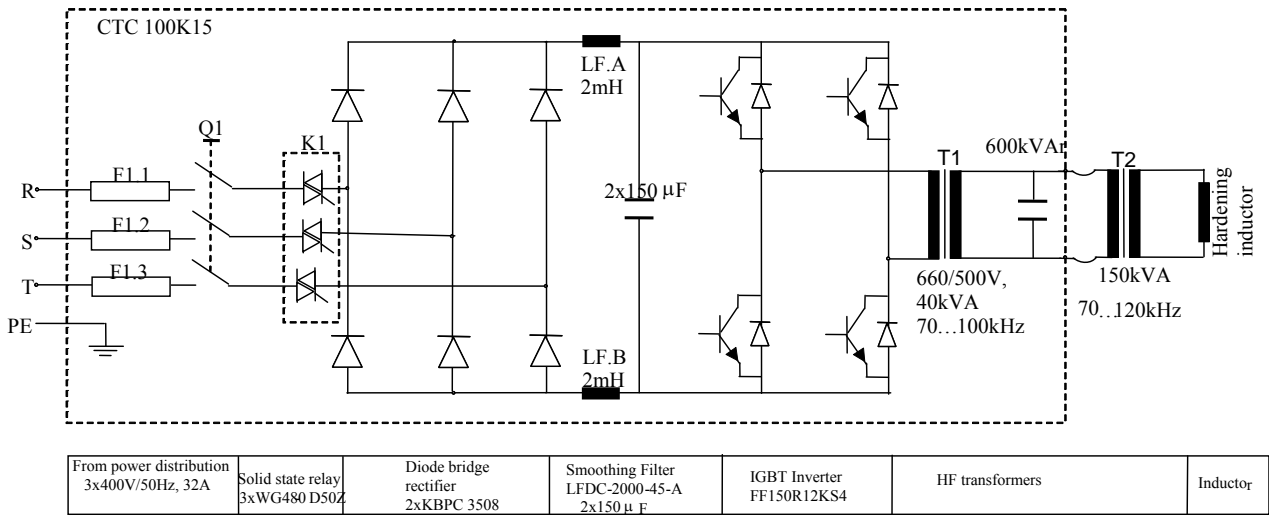

Fig.1. Hardening electrothermal installation.

frequency, RMS values for line and phase voltages and currents, crest factor and THD generated by line and phase voltages and currents, active, reactive and apparent powers, power factor and displacement power factor. All these electrical parameters have graphical representations selecting different channels [2].

3.2 Electrical parameters computing

In the following paragraph, the authors present the mathematical relations used in computing the measured electrical parameters.

Measurement for RMS voltage and currents are computed according to the following relations [5]:

$$V_{rms}(i) = \sqrt{\frac{1}{N} \cdot \sum_{n=0}^{N-1} V(i,n)^2} \quad (1)$$

where: V_{rms} - RMS phase voltage;

$$U_{rms}(i) = \sqrt{\frac{1}{N} \cdot \sum_{n=0}^{N-1} U(i,n)^2} \quad (2)$$

where: U_{rms} - RMS line voltage;

$$A_{rms}(i) = \sqrt{\frac{1}{N} \cdot \sum_{n=0}^{N-1} A(i,n)^2} \quad (3)$$

where: $A_{rms}(i)$ - Effective phase current;

In relations (1) – (3) N represents the number of samples for one periode of the input signal and i represents the number of the phase.

Peak factor for voltage and currents are computed according to the following relations [5]:

$$V_{cf}(i) = \frac{\max(V_{max+}(i), V_{max-}(i))}{\sqrt{\frac{1}{N} \cdot \sum_{n=0}^{N-1} V(i,n)^2}} \quad (4)$$

$$U_{cf}(i) = \frac{\max(U_{max+}(i), U_{max-}(i))}{\sqrt{\frac{1}{N} \cdot \sum_{n=0}^{N-1} U(i,n)^2}} \quad (5)$$

$$A_{cf}(i) = \frac{\max(A_{max+}(i), A_{max-}(i))}{\sqrt{\frac{1}{N} \cdot \sum_{n=0}^{N-1} A(i,n)^2}} \quad (6)$$

In relations (4) – (6) V_{max+} , U_{max+} and A_{max+} represent the maximum value of the positive half-period of the phase voltage, line voltage and phase current and V_{max-} , U_{max-} and A_{max-} represent the minimum value of the negative half-period of the same parameters.

Distortion factor can be computed taking into consideration that there are two global values that give the relative quantity of harmonics: total harmonic distortion (THD) against the fundamental and the distortion factor (DF) against the effective value (RMS).

$$V_{thd}(i) = \frac{\sqrt{\sum_{n=2}^{50} V_{harm}(i,n)^2}}{V_{harm}(i,1)}, \quad V_{df}(i) = \frac{\sqrt{\sum_{n=2}^{50} V_{harm}(i,n)^2}}{V_{rms}(i)} \quad (7)$$

$$U_{thd}(i) = \frac{\sqrt{\sum_{n=2}^{50} U_{harm}(i,n)^2}}{U_{harm}(i,1)}, \quad U_{df}(i) = \frac{\sqrt{\sum_{n=2}^{50} U_{harm}(i,n)^2}}{U_{rms}(i)} \quad (8)$$

$$A_{thd}(i) = \frac{\sqrt{\sum_{n=2}^{50} A_{harm}(i,n)^2}}{A_{harm}(i,1)}, \quad A_{df}(i) = \frac{\sqrt{\sum_{n=2}^{50} A_{harm}(i,n)^2}}{A_{rms}(i)} \quad (9)$$

The three phase electric powers are computing with relations [5]:

$$P(i) = \frac{1}{N} \cdot \sum_{n=0}^{N-1} V(i,n) \cdot A(i,n) \quad (10)$$

$$S(i) = V_{rms}(i) \cdot A_{rms}(i) \quad (11)$$

$$Q(i) = \frac{1}{N} \cdot \sum_{n=0}^{N-1} V\left(i, n - \frac{N}{4}\right) \cdot A(i,n) \quad \text{or} \quad (12)$$

$$Q(i) = \sqrt{S(i)^2 - P(i)^2}$$

where: $P(i)$ is the active power, $Q(i)$ is the reactive power and $S(i)$ is the aparent power on the i phase.

The power factor is computed based on electric powers using the relation:

$$PF(i) = \frac{P(i)}{S(i)} \quad (13)$$

3.3 QualiStar View software, version 2.5

By RS232 serial interface, data can be transferred to a personal computer in order to be analyzed using a dedicated software, like QualiStar View.

QualiStar View [3] can create different types of files (transient mode, permanent mode, recorded alarms, screen copies). Data aquisition in transient mode needs a sampling period $T=0.1ms$ and in permanent mode $T=1s$.

Data can be exported to Microsoft Excel files in order to be analyzed in tables form. Using appropriate formulas it can be obtained variations of the other electrical parameters.

4. Measurement set of electrical parameters

In this chapter the authors present a measurement set of the electrical parameters recorded during the functioning of the electro thermal installation with electromagnetic induction.

In the followings, the authors present the variation of electrical parameters measured with the HF transformer T2 at 5:1 transformation ratio (500/100V) and 3:1 transformation ratio (500/167V) made in transient mode and permanent mode. The consumed active power can be adjusted in stages, so the chosen values for making the measurements are 4,5kW, 9kW and 15kW.

Figures 2, 3, 4 present the variation of the phase voltage and currents in transient mode on phase 1, 2 and 3 for active power $P=4,5kW$, 9kW and 15kW at 5:1 transformation ratio. Figures 5, 6, 7 present the variation of the phase voltage and currents in transient mode on phase 1, 2 and 3 for active power $P=4,5kW$, 9kW and 15kW at 3:1 transformation ratio.

In permanent mode the authors choose to represent the following electrical parameters [3]: (the name of parameters are generated by QualiStar View)

$-U_{RMS}$ [V] is line voltage (RMS value), 3 phase representation



Fig. 2. Variation of the phase voltage and currents in transient mode for $P = 4,5kW$, 5:1 transf.ratio.



Fig. 3. Variation of the phase voltage and currents in transient mode for $P = 9kW$, 5:1 transf.ratio.

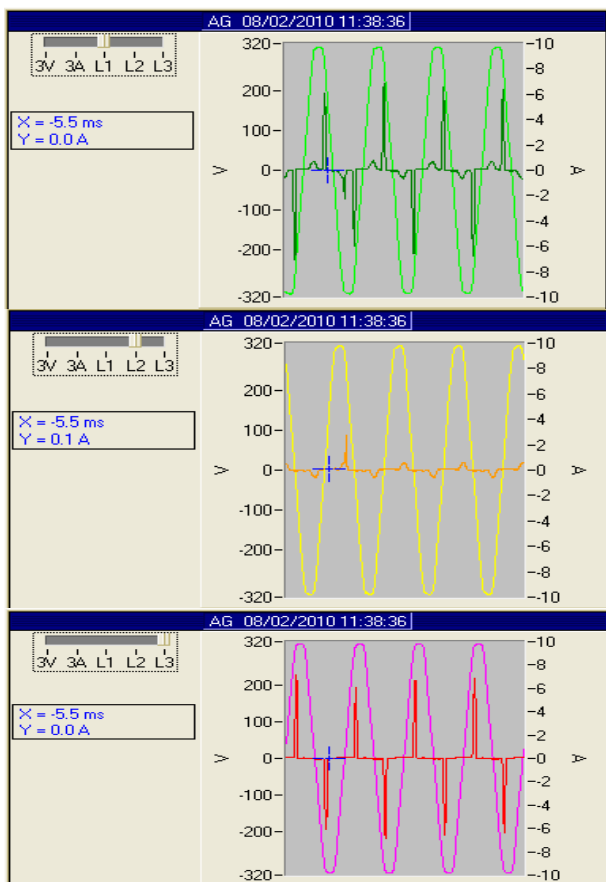

Fig. 4. Variation of the phase voltage and currents in transient mode for $P = 15\text{kW}$, 5:1 transf.ratio.

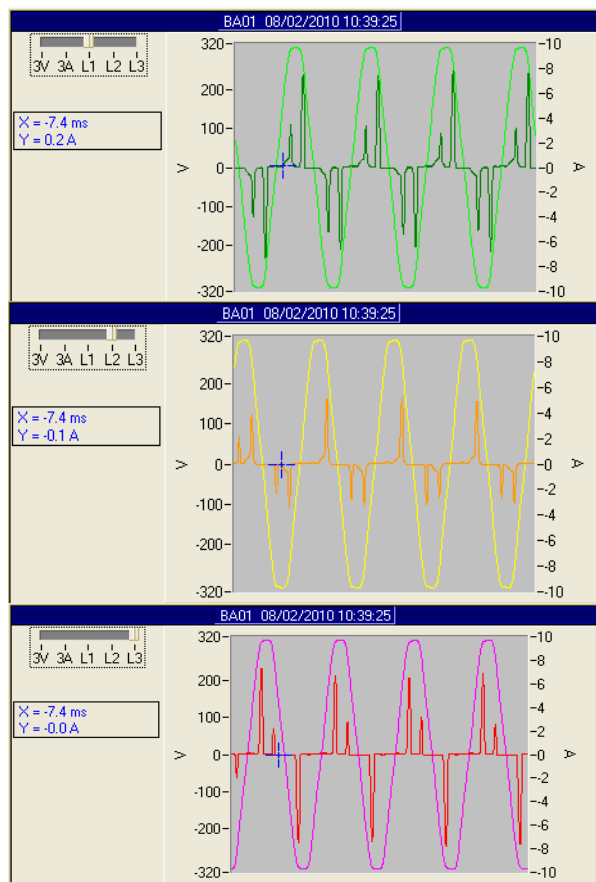

Fig. 6. Variation of the phase voltage and currents in transient mode for $P = 9\text{kW}$, 3:1 transf.ratio.



Fig. 5. Variation of the phase voltage and currents in transient mode for $P = 4,5\text{kW}$, 3:1 transf.ratio.

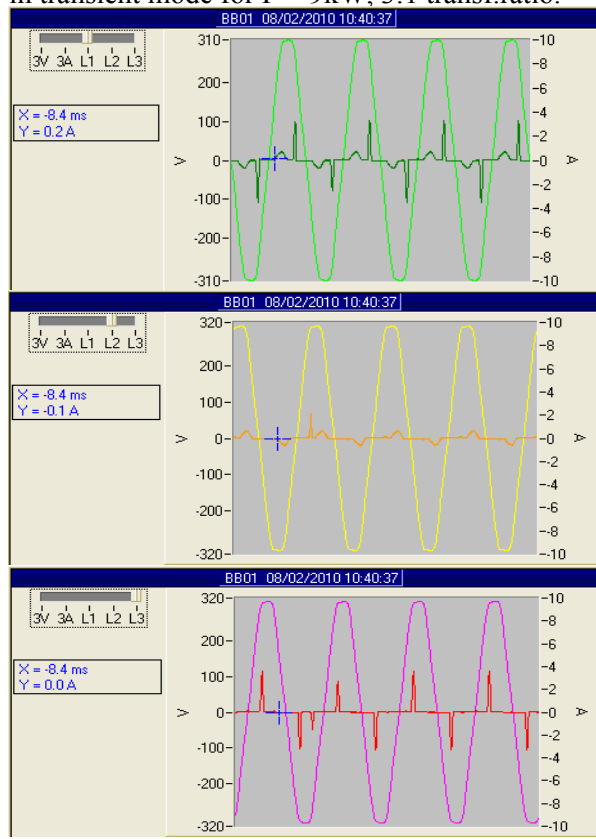

Fig. 7. Variation of the phase voltage and currents in transient mode for $P = 15\text{kW}$, 3:1 transf.ratio.

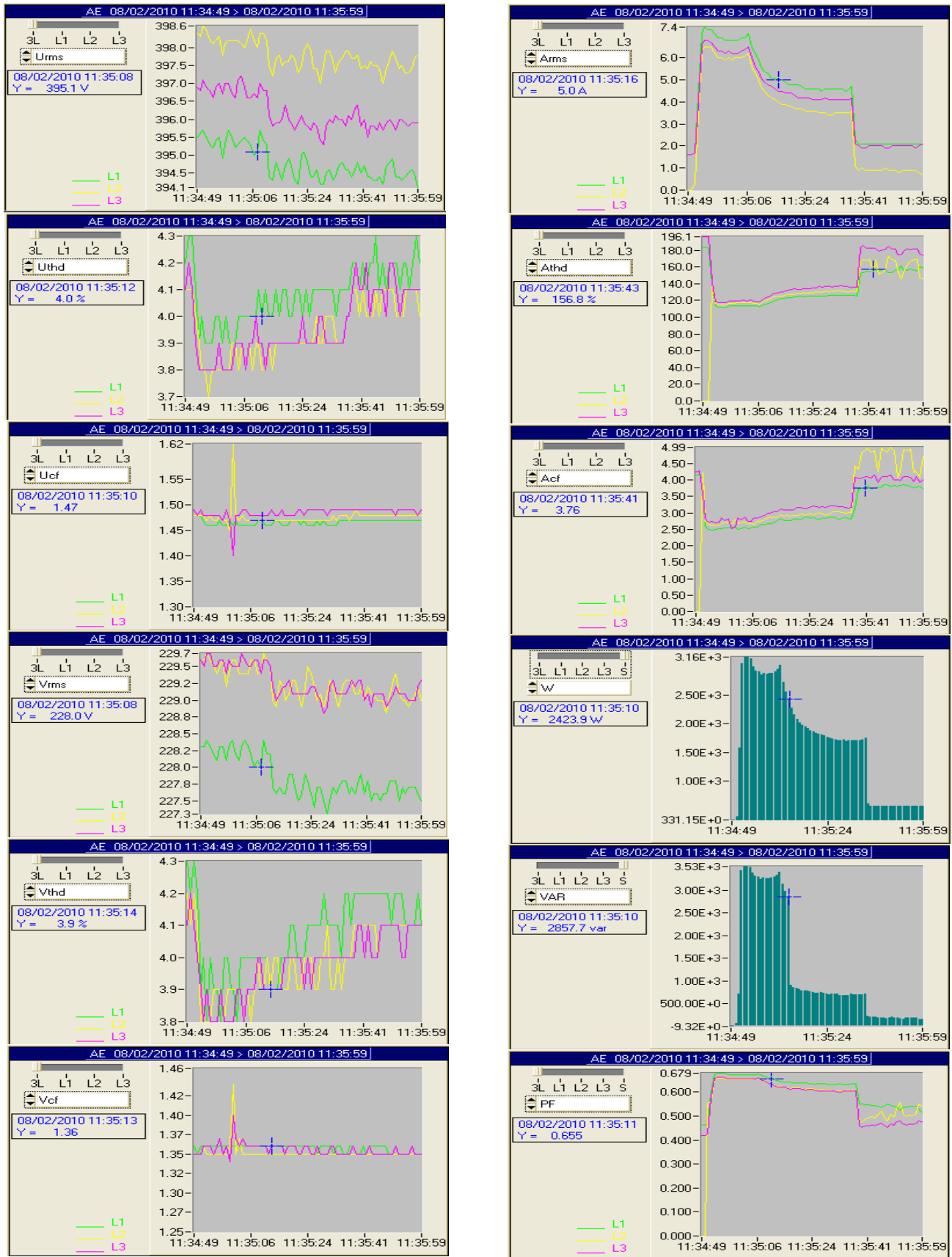

Fig. 8. Variation of the electrical parameters in permanent mode for $P = 4.5kW$, 5:1 transformation ratio.

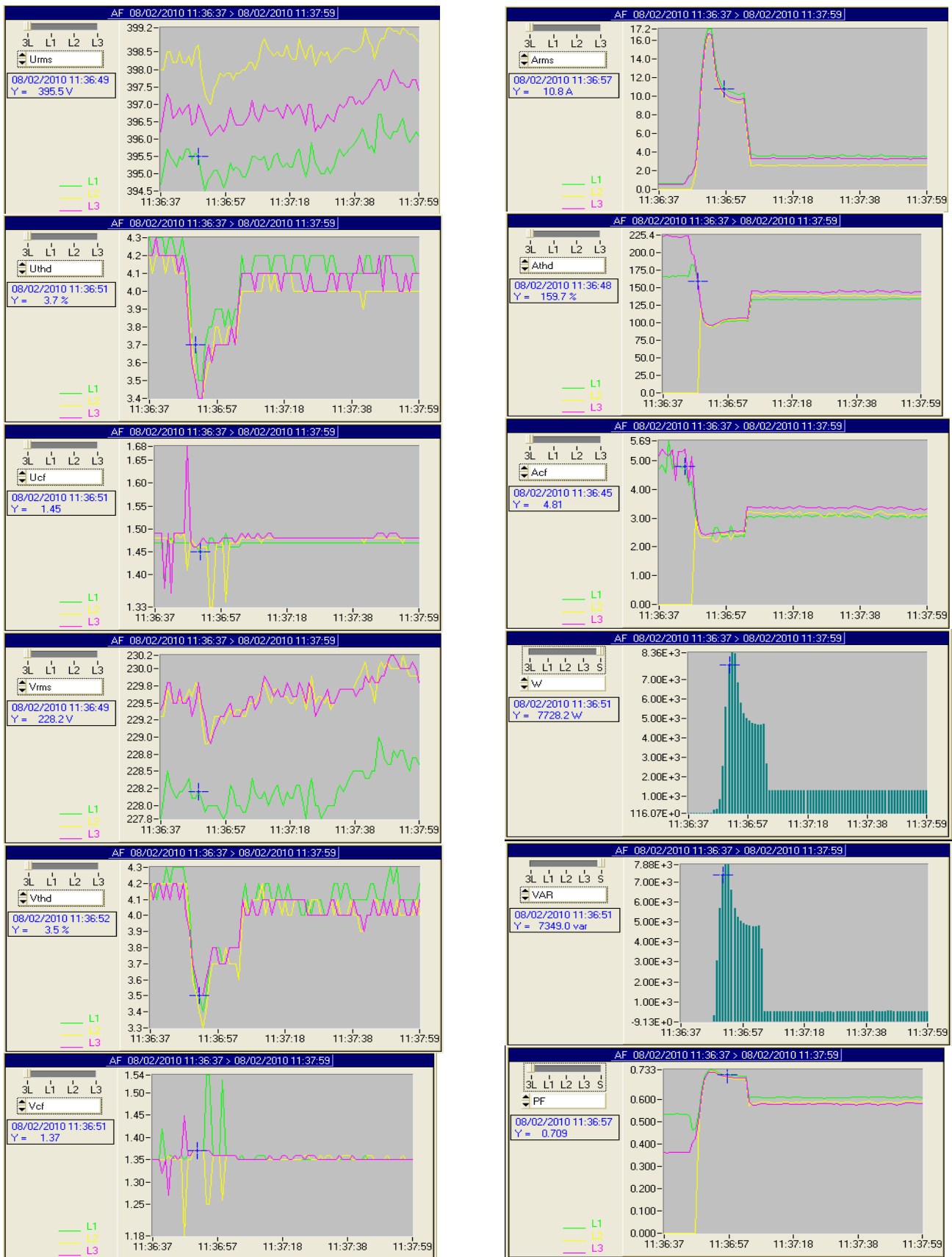

Fig. 9. Variation of the electrical parameters in permanent mode for $P = 9\text{kW}$, 5:1 transformation ratio.

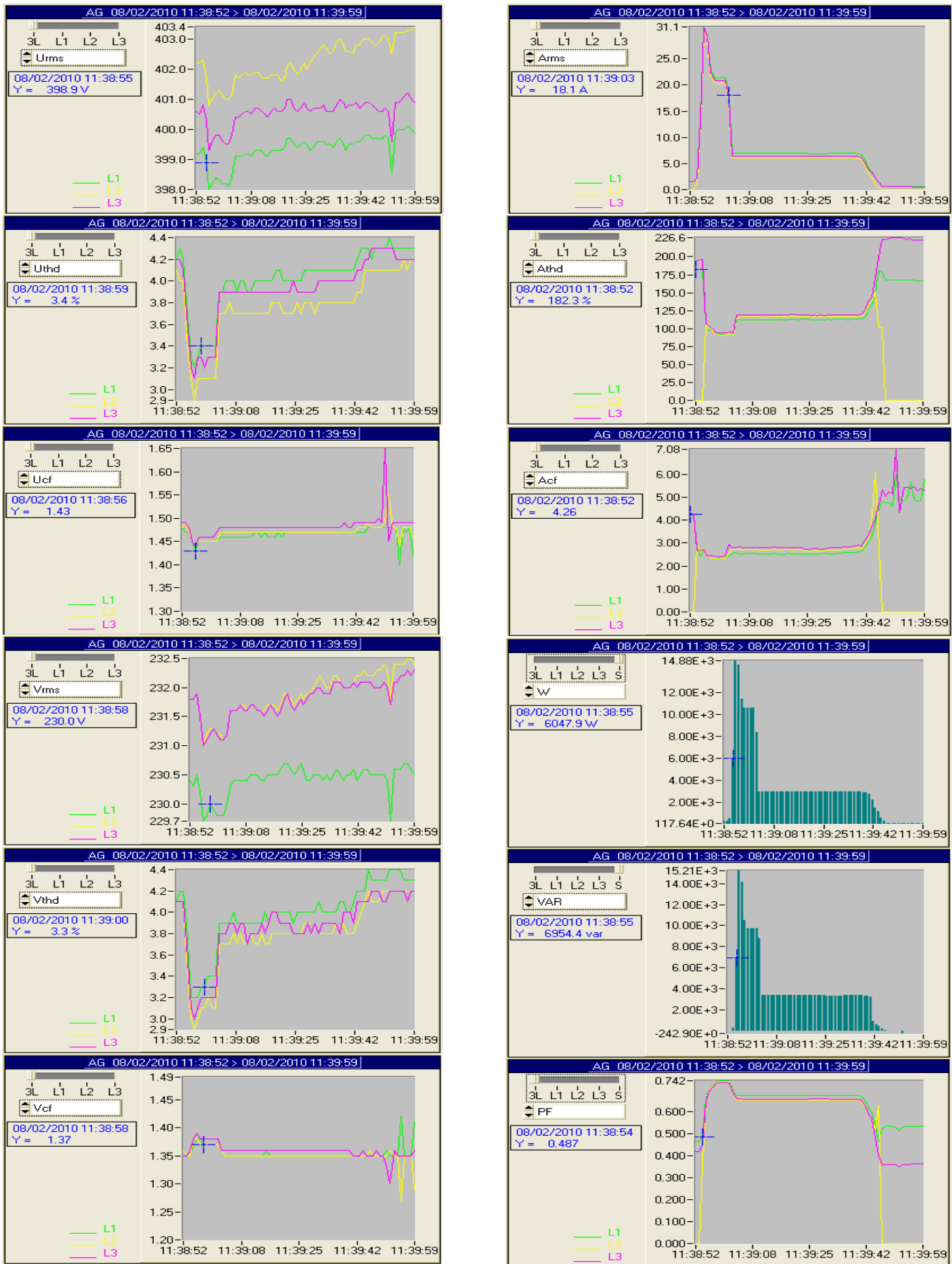

Fig. 10. Variation of the electrical parameters in permanent mode for P = 15kW, 5:1 transformation ratio.

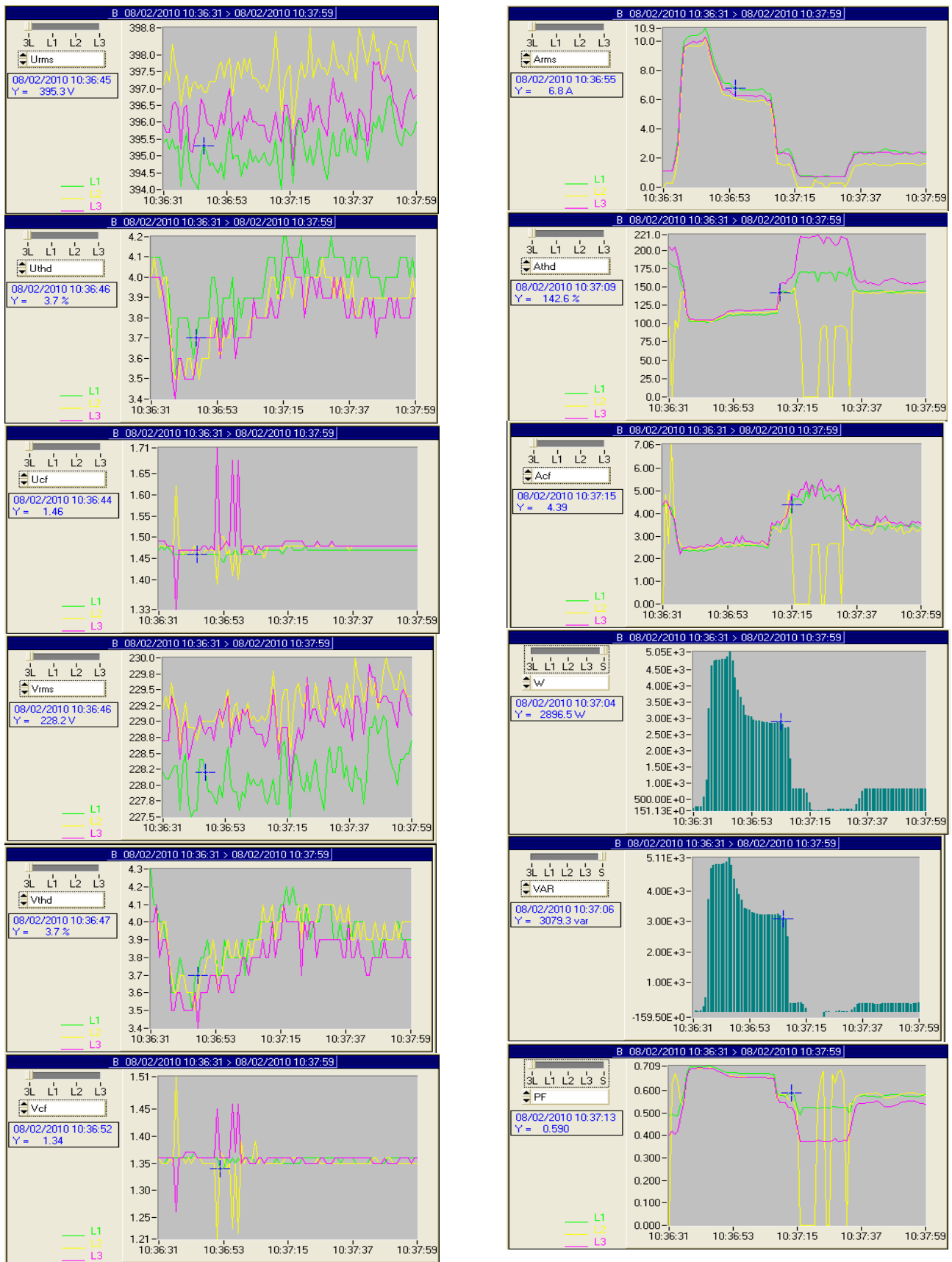

Fig. 11. Variation of the electrical parameters in permanent mode for $P = 4,5kW$, 3:1 transformation ratio.

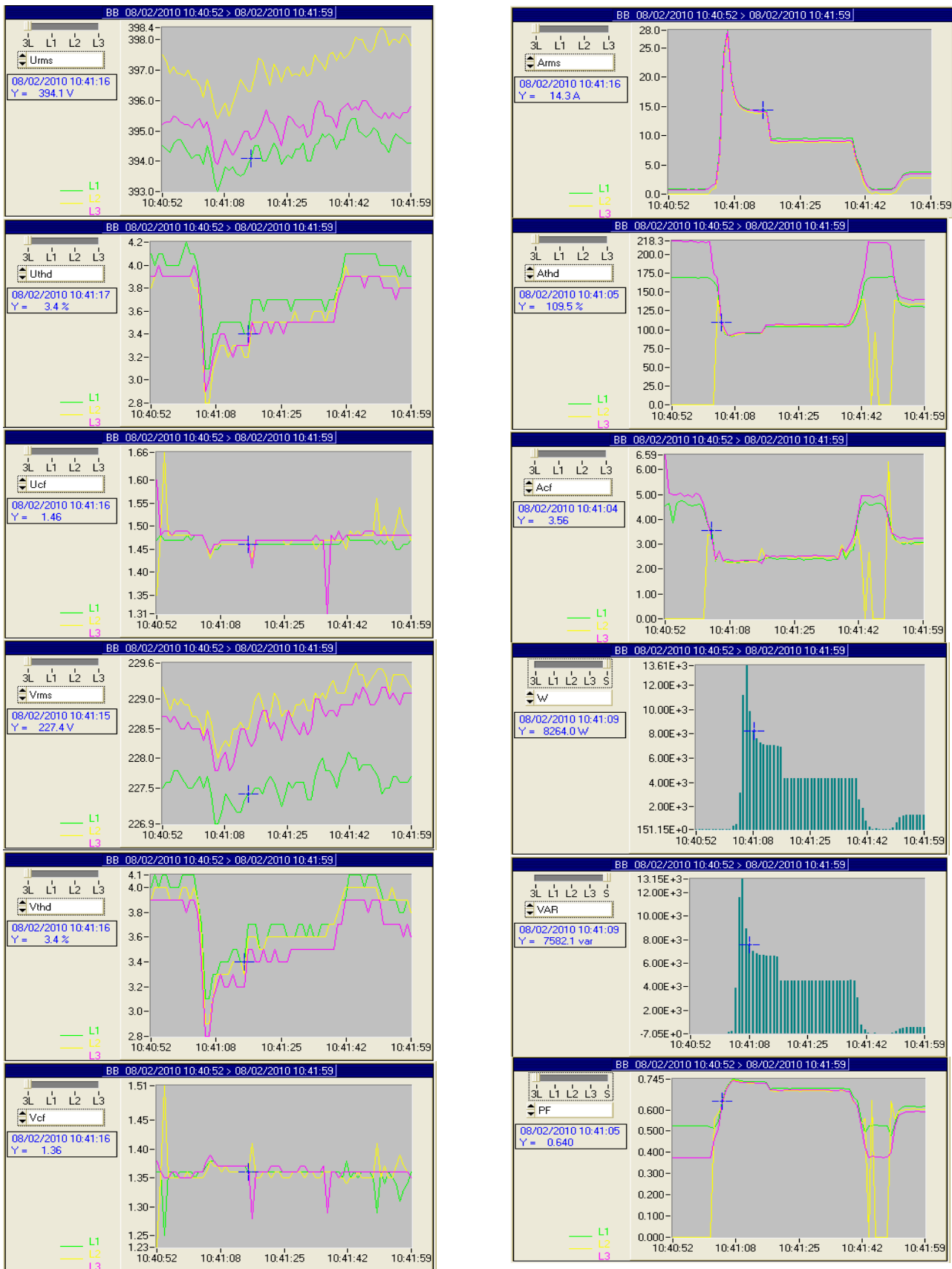

Fig. 12. Variation of the electrical parameters in permanent mode for P = 15kW, 3:1 transformation ratio.

- U_{THD} [%] is THD generated by line voltage, 3 phase representation
- U_{CF} [-] is the peak amplitude of line voltage divided by the RMS value of line voltage
- V_{RMS} [V] is phase voltage (RMS value), 3 phase representation
- V_{THD} [%] is THD generated by phase voltage, 3 phase representation
- V_{CF} [-] is the peak amplitude of phase voltage divided by the RMS value of phase voltage
- A_{RMS} [A] is phase current (RMS value), 3 phase representation
- A_{THD} [%] is THD generated by phase currents, 3 phase representation
- A_{CF} [-] is the peak amplitude of phase currents divided by the RMS value of line currents
- W [W] is active power, sum of the 3 phase values.
- VAR [VAR] is reactive power, sum of the 3 phase values
- PF [-] is power factor, 3 phase representation

Figures 8, 9 and 10 represent the variation of the electrical parameters described above in permanent mode for $P = 4,5kW$, $9kW$ and $15kW$ at 5:1 transformation ratio. Figures 11 and 12 represent the variation of the electrical parameters described above in permanent mode for $P = 4,5kW$ and $15kW$ at 3:1 transformation ratio.

5. Conclusions

Measurements in transient mode

Studying the variation of the electrical parameters in transient mode, it can be seen that the phase voltages are sinusoidal and have the same amplitudes on three phases. The current waveform is typically, there are two positive and two negative peaks in one period. This type of variation is very obvious on phases L1 and L2. On phase L3 the peak with the lower amplitude is missing.

Measurement in permanent mode at $P=4,5kW$

Examining the variation of the electrical parameters from fig. 8 and 11, it can be observed that the power system is unbalanced, the effective values for line voltages U_{RMS} are varying from 394.1V to 398.6V. THD generated by the line voltages U_{THD} oscillates around 4%. When U_{RMS} is decreasing, it can be observed an increasing for U_{THD} .

THD generated by the phase voltages V_{THD} has the same variation as U_{THD} . Studying the variation of the phase voltages, V_{RMS} , it can be seen that only phase L1 is unbalanced from phases L2 and L3. THD generated by the phase voltages V_{THD} is around 4%.

It is very important to notice that it has been recorded

a value for THD generated by line currents of 120-180%. A_{THD} varies in reverse proportion with A_{RMS} . The increasing of A_{THD} generates a decreasing of active power. Total active power on 3 phases is maximum 3.1kW and reactive power is maximum 3.5kVAR. Power factor varies between 0.45 and 0.7.

The amplitude variation of phase and line voltage at 3:1 transformation ratio is higher than in case of 5:1 and the active power is increasing at 3:1 transformation ratio.

Measurement in permanent mode at $P=9kW$

The power system is unbalanced, the line voltages varies from 394V to 399V. After some variations, the active power remains constant at 2kW and the power factor at 0.6.

Measurement in permanent mode at $P=15kW$

The effective value for line voltage U_{THD} changes between 398 and 403V, the power system is unbalanced, like in case with $P=4,5kW$, phase L1 has the lowest voltage value and phase L2 has the highest value.

THD generated by the line voltages U_{THD} varies proportionally with U_{THD} . This case is recorded as well in variation of THD generated by the phase voltages V_{THD} . The maximum effective value for line current is 31.1A. When A_{RMS} is decreasing, A_{THD} is increasing. The maximum value for active power is 14.8kW and for reactive power is 15.2kVAR. Power factor varies between 0.4 and 0.74.

References

- [1] SC AAGES Ltd. Târgu Mureș, *Transistor based frequency converter type CTC 100K15. Electrical documentation.*
- [2] Chauvin Arnoux, *Three phase power quality analyzer CA 8332B, CA 8334B. User's manual.*
- [3] www.chauvin.arnoux.com
- [4] N. Golovanov, I. Șora ș.a., *Electro-thermia and electro-technologies*, Tehnical publishing, București, 1997.
- [5] Baciú I., Cuntan C., Panoiu C., Popa G., *Using passive filters for reducing the current harmonics introduced in the line voltage supply by DC motors functioning*, Proceedings of the 13th WSEAS International Conference On Systems, Rhodes, Greece, pp. 260-265.
- [6] Rob R., Sora I., Panoiu C., Panoiu M., *Researches regarding the electric energy quality on high frequency electrothermal installation with electromagnetic induction*, Proceedings of the 8th WSEAS International Conference On Systems Science and Simulation, Genova, Italy, pp. 288-293.