

Minimization of Shaft Torsional Oscillations by Fuzzy Controlled Braking Resistor Considering Communication Delay

MOHD. HASAN ALI, MINWON PARK, AND IN-KEUN YU

Department of Electrical Engineering
Changwon National University
9 Sarim-Dong, Changwon, Gyeongnam, 641-773
SOUTH KOREA
hasansim@changwon.ac.kr

Abstract: - This paper analyzes the effect of the fuzzy logic-controlled braking resistor (BR) on minimizing shaft torsional oscillations of the generators in a multi-machine power system. The influence of communication delay associated with the fuzzy controller input calculation on minimizing shaft torque oscillations is investigated. Global Positioning System (GPS) is proposed for the practical implementation of the calculation of the input of the fuzzy logic controller. Communication delays may affect the control system, and consequently the performance of minimizing shaft torsional oscillations also. A prediction function is proposed to reduce the negative effect caused by the communication delay on minimizing shaft torsional oscillations. Simulation results of a balanced fault at different points in the power system show that the fuzzy logic-controlled braking resistor can minimize the shaft torsional oscillations of synchronous generators well. Moreover, the communication delay has an influence on minimization of shaft torque oscillations. Also, the negative effect caused by the communication delay on minimizing shaft torsional oscillations can be reduced by the prediction method.

Key-Words: - Braking resistor, Communication delay, Fuzzy controller, Global positioning system (GPS), Minimizing shaft torsional oscillations, Prediction function, TKED.

1 Introduction

Usually, in the analysis of power system dynamic performance, the rotor of the turbine-generator is assumed to be made of a single mass. However, in reality, a turbine-generator rotor has a very complex mechanical structure consisting of several predominant masses (such as rotors of turbine sections, generator rotor, couplings, and exciter rotor) connected by shafts of finite stiffness. Therefore, when the generator is perturbed, torsional oscillations result between different sections of the turbine-generator rotor. The torsional oscillations in the subsynchronous range could, under certain conditions, interact with the electrical system in an adverse manner [1]. Again, certain electrical system disturbance can significantly reduce the life expectancy of turbine shafts. Therefore, sufficient damping is needed to reduce turbine shaft torsional oscillations.

Braking resistor (BR) is known to be a very effective device for transient stability control [2-5]. It can be viewed as a fast load injection to absorb excess transient energy of an area which arises due to severe system disturbances. The braking resistor can be used to damp shaft torsional oscillations of

synchronous generator also [6-7]. But in [6-7], conventional controllers were used to switch in and out the BR. As a result, these strategies are inflexible and are not adaptive to the changing operating condition of the system. To surmount such drawbacks, fuzzy logic-controlled BR was proposed for damping shaft torsional oscillations [8-10]. However, in all of the results [6-10], the analysis of damping shaft torsional oscillations was carried out in case of a single machine power system only.

This paper analyzes the effect of the fuzzy logic-controlled braking resistor on minimizing shaft torsional oscillations of synchronous generators in case of a large multi-machine power system. The total kinetic energy deviation (TKED) of the synchronous generators is used as the input to the fuzzy controller for BR switching [2] in this work. However, a communication delay is introduced in online calculation of the TKED, which may fatally affect the control system. Consequently, minimization of shaft torsional oscillations of the generators would be affected. So, the communication delay phenomenon associated with the online calculation of the fuzzy controller input should be considered for the actual analysis of shaft

torsional oscillations minimization. In [2-10], such communication delays are not considered.

The most important and novel feature of this work is that it analyzes the effect of communication delays introduced in online calculation of the input variable of the fuzzy controller for braking resistor switching on the shaft torque oscillations minimization of synchronous generators in a multi-machine power system. Global Positioning System (GPS) [11-12] is proposed for the practical implementation of the calculation of the input of the fuzzy logic controller. Furthermore, a prediction function is proposed to reduce the negative effect caused by the communication delay on shaft torque oscillations minimization by the fuzzy controlled braking resistor.

The organization of this paper is as follows: Section 2 describes the model system for the proposed study. Section 3 explains the procedure for the online calculation of TKED using GPS. In section 4, the design of the fuzzy logic controller is explained. Section 5 describes the simulation results. Finally, section 6 provides conclusions regarding this work.

2 Model System

For the simulation, the IEEJ West 10-machine model system [2], [4] as shown in Fig. 1 has been used. The “WEST 10-machine system” model is a 10-machine tandem model that is a prototype of the Japanese 60 Hz systems. It presents the long time oscillation characteristics of a tandem system [2], [4]. The model system has 10 generators, G1 to G10, as shown in Fig.1. Generator G10 is considered as the swing generator in the system. All lines in Fig.1 represent 2 circuits of 3-phase transmission line. In this work, two braking resistors are installed at the terminal busses of generators G1 and G10. The conductance values of these two braking resistors are selected from the viewpoint that they can absorb an amount of power equal to the rated capacity of the machines at full conduction. The system base is 1000 MVA. Therefore, the conductance values of the braking resistors BR1 and BR10 are considered to be 15.0 pu and 30.0 pu, respectively. Fig. 2 shows that a braking resistor BR with a conductance value of G_{TCSBR} is connected to a generator terminal bus through a thyristor switching circuit.

In this work, the difference between the total kinetic energy (W_{total}) of the generators at transient state and that at steady state is defined as total kinetic energy deviation, TKED, i.e., $TKED = (W_{total} \text{ at transient state}) - (W_{total} \text{ at steady state})$. The BR

will be switched in following a fault clearing and the switching condition of BR is such that when TKED exceeds 0.80 pu, BR is switched on the generator terminal bus. On the other hand, when TKED is below or equal to 0.80 pu and also in the steady state, BR is removed from the generator terminal bus by the thyristor switching circuit. The dead band of the BR operation i.e. the threshold value of TKED is determined by trial and error in order to obtain the best system performance. The AVR (Automatic Voltage Regulator) and GOV (Governor) control system models for the IEEJ West 10-machine model system [2] have been included in the present simulation. Various parameters of the generators used for the simulation are described in [2].

It is considered that each turbine-generator shaft model has 6 (six) masses namely high-pressure (HP) turbine, an intermediate-pressure (IP) turbine, two low-pressure turbines (LPA, LPB), the generator (GEN) and exciter (EXC) as shown in Fig. 3. Rotor spring mass constants as shown in Table 1 are described in [9-10].

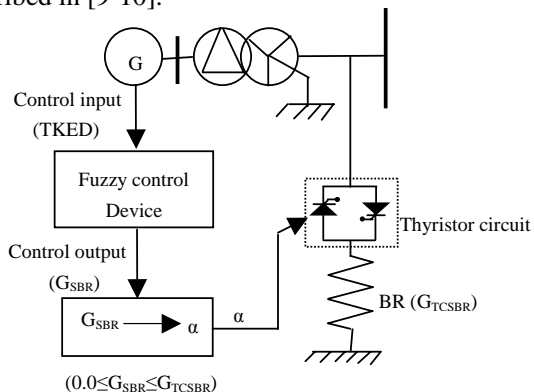

Fig. 2. BR with thyristor switching circuit.



Fig. 3. Turbine-generator shaft model.

Table 1. Rotor spring mass parameters

Mass	Shaft	Inertia H (second)	Spring constant	
			K (pu)	pu Torque/rad
HP		0.225	7.277	19.303
	HP-IP			
IP		0.376	13,168	34.929
	IP-LPA			
LPA		2.077	19,618	52.038
	LPA-LPB			
LPB		2.139	26,713	70.858
	LPB-GEN			
GEN		2.101	1,064	2.822
	GEN-EXC			
EXC		0.082		

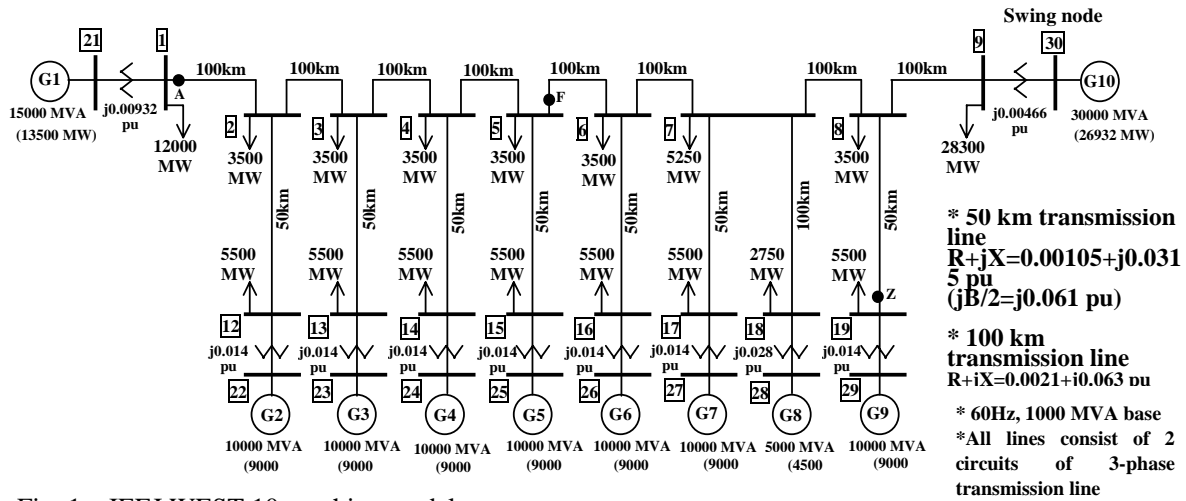

Fig. 1. IEEJ WEST 10-machine model system.

3 Online Calculation of TKED Using GPS

In this work, TKED is used as the fuzzy controller input for BR switching. TKED is already defined in section 2. According to the definition, in order to calculate TKED, W_{total} is needed, which can be determined easily by knowing the rotor speed of each generator and is given by:

$$W_{total} = \sum_{i=1}^N W_i \quad (J) \quad (1)$$

where $W_i = \frac{1}{2} J_i \omega_{mi}^2 \quad (J) \quad (2)$

denotes kinetic energy in joule for a generator, W_{total} total kinetic energy in joule, i generator number, and N total number of generators. Again, in (2) $J_i = (H \times MVA \text{ rating}) / \{5.48 \times 10^{-9} \times (N_s)^2\}$ denotes moment of inertia in $Kg.m^2$ where N_s and H are synchronous angular speed in rpm and inertia constant respectively and $\omega_{mi} = 2 \times \pi \times (N/60)$ rotor angular velocity in mechanical rad/sec where N is rotor speed in rpm.

3.1 GPS Method for the Online Calculation of TKED

The online calculation of TKED using the speed signal of each generator, and then again using the signal of TKED as the input to each fuzzy controller can be accomplished by using GPS (Global Positioning System) [11-12] which provides time synchronization of signals. It has recently been recognized that synchronized measurement of power system quantities is feasible using the GPS, since GPS can easily and precisely provide a time signal,

with a $1\mu s$ accuracy, at any location on the power network [12].

Fig. 4 shows a simplified functional block diagram where the GPS receiver collects the digitalized speed equivalent signals of the generators, and synchronizes the signals in a common timing reference. The synchronized signals are then sent to a central control office where W_{total} as well as TKED is calculated. Data output i.e. the signal of TKED is then sent to each fuzzy controller input. In this case, signals may be transmitted and received through microwave or optical fibre.

3.2 Communication Delays

During online calculation of TKED, time delays are introduced mainly due to signal transmission through optical fibre or microwave, A/D conversion, calculation of W_{total} as well as TKED, and time synchronization of signals by GPS. The communication delays may affect the control logic, and consequently minimization of shaft torsional oscillations of the generators also. So, such communication delays should be considered for the actual analysis of shaft oscillations minimization.

Usually, communication delays may range from several microseconds to few hundred milliseconds [13-15]. In this work, extensive simulations are carried out considering various values of communication delays. Some of the simulation cases are shown in Figs. 6-8.

3.3 Implementation of Communication Delay in the Control System

In this work, simulations are carried out by using EMTP (Electro-Magnetic Transients Program), a special transient simulation program which can

predict variables of interest in electric power networks as functions of time, typically following some disturbances such as the switching of a circuit breaker, or a fault [16]. During the simulations, various values of communication delays are applied to the controller input signal through the EMTP TACS (Transient Analysis of Control Systems) code no. 53 i.e. the transport delay code of EMTP.

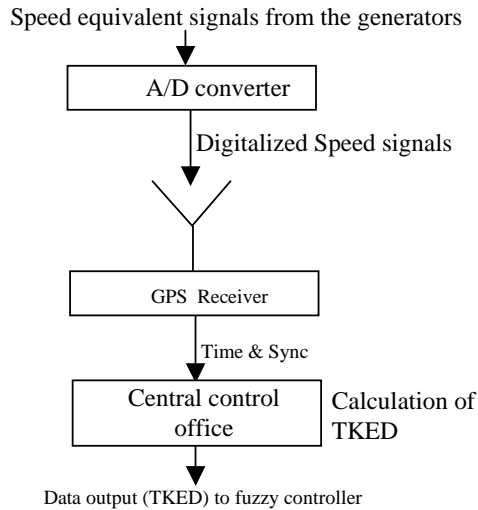

Fig. 4. GPS functional block diagram.

4 Design of Fuzzy Logic Controller

The design of the proposed FLC (Fuzzy Logic Controller) is described in the following:

4.1 Fuzzification

For the design of the proposed fuzzy logic controller, TKED of the generators and conductance value of BR, G_{SBR} ($0.0 \leq G_{SBR} \leq G_{TCSBR}$), are selected as the input and output respectively. The use of single input and single output variable makes the fuzzy controller very straightforward [2-4]. We have selected the triangular membership functions for TKED as shown in Fig. 5 in which the linguistic variables Z, PS, and PB stand for Zero, Positive Small, and Positive Big respectively. It is important to note that the membership functions for TKED are determined by trial and error in order to obtain the best system performance. The equation of the triangular membership function used to determine the grade of membership values is as follows [17-18]:

$$\mu_A(TKED) = 1/b(b-2/TKED-a) \quad (3)$$

where $\mu_A(TKED)$ is the value of grade of membership, 'b' is the width, 'a' is the coordinate of

the point at which the grade of membership is 1, and 'TKED' is the value of the input variable.

4.2 Fuzzy Rule Table

The proposed control strategy is very simple because it has only 3 control rules for each controller. The control rules are shown in Table 2 where the numerical values of G_{SBR} represent the output of the fuzzy controller. It is important to note that the control rules have been developed from the viewpoint of practical system operation and by trial and error.

Table 2. Fuzzy rule table

TKED [pu]	G_{SBR} [pu]	
	BR1	BR10
Z	5.0	0.1
PS	10.0	0.2
PB	15.0	2.0

4.3 Fuzzy Inference

For the inference mechanism of the proposed fuzzy logic controller, Mamdani's method [17-18] has been utilized. According to Mamdani, the degree of conformity, W_i , of each fuzzy rule is as follows:

$$W_i = \mu_A(TKED) \quad (4)$$

where $\mu_A(TKED)$ is the value of grade of membership and i is rule number.

4.4 Defuzzification

The Center-of-Area method is the most well-known and rather simple defuzzification method [17-18] which is implemented to determine the output crispy value (i.e. the conductance value of BR, G_{SBR}). This is given by the following expression.

$$G_{SBR} = \frac{\sum W_i C_i}{\sum W_i} \quad (5)$$

where C_i is the value of G_{SBR} in the fuzzy rule table.

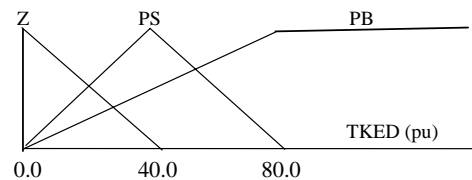

Fig. 5. Membership functions of TKED.

The firing control signal can be determined from the conductance value, G_{SBR} , and then sent to the thyristor switching unit to modify the real power absorbed by the braking resistor in the transient condition. The method of calculating firing-angle

from the output of the fuzzy controller is described in detail in [3].

5 Simulation Results and Discussion

In this work, simulations have been carried out considering a balanced (3LG: three-phase-to-ground) fault at points A, F, and Z as shown in Fig. 1. In all of the cases the fault occurs at 0.1 sec, the circuit breakers on the faulted lines are opened at 0.17 sec, and at 1.003 sec the circuit breakers are closed. It is assumed that the circuit breaker clears the line when the current through it crosses the zero level. The time step and simulation time have been chosen as 0.00005 sec and 10.0 sec respectively.

Figs. 6 and 7 show the effects of the fuzzy logic-controlled BR on minimizing shaft torsional oscillations of generator G1 in case of 3LG fault at point A without considering and considering a communication delay of 20 msec, respectively. From the responses of Figs. 6 and 7 it is clear that the fuzzy controlled braking resistor can minimize the shaft torsional oscillations well during a severe fault. It is also observed that the minimizing performance of BR considering a communication delay of 20 msec as demonstrated in Fig. 7 is worse than that without considering a communication delay as demonstrated in Fig. 6. This fact indicates that the communication delay has an effect on minimizing shaft torsional oscillations by the fuzzy controlled BR.

During the simulations it was observed that, if the communication delay was greater than 500 msec, the system performance was not good.

5.1 Control Methodology to Reduce the Negative Effect Caused by Communication Delay on Minimizing Shaft Torsional Oscillations

Usually, the time delay problem can be solved or compensated by the well-known Smith Predictor [19-20] method. However, the Smith Predictor method uses the transfer function of the entire system. On the other hand, fuzzy logic controller does not require a transfer function of the system. In this work, since fuzzy logic controller is used for braking resistor switching, the Smith Predictor method cannot be used for time delay compensation. Therefore, in this work, the prediction function [21-22] as shown in (6) is used to reduce the negative effect caused by the communication delay on minimizing shaft torsional oscillations by the fuzzy controlled braking resistor.

$$W_{totalP} = W_{total} + (t_d \times \frac{dW_{total}}{dt})K \quad (6)$$

In (6), W_{totalP} is the predicted value of total kinetic energy, t_d is the time delay, and K is a coefficient determined by trial and error in order to obtain the best system performance. In this work, K is chosen 0.01.

As already explained in section 3.3, before applying to the controller, the input signal is delayed by an amount of communication delay. In the proposed prediction method, at first W_{total} is delayed by an amount of communication delay and then it is modified to W_{totalP} using (6), and finally the W_{totalP} is applied to the fuzzy controller input. Fig. 8 shows the shaft torsional oscillation responses using the proposed prediction function in case of a communication delay of 20 msec. It is seen that the oscillation minimization performance using fuzzy controlled braking resistor as shown in Fig. 8 is better than that as shown in Fig. 7. Moreover, the torque responses using fuzzy controlled braking resistor as shown in Fig. 8 are almost the same as those shown in Fig. 6. These facts indicate that the negative effect caused by the communication delay on minimizing shaft torsional oscillations can be reduced by using the proposed prediction method.

6 Conclusion

This paper analyzes the influence of communication delays associated with the online input calculation of the fuzzy controller for braking resistor switching on minimizing shaft torsional oscillations of the generators in a multi-machine power system. From the simulation results of a balanced fault at different points in the system, the following conclusions can be drawn.

- The fuzzy logic-controlled braking resistor can minimize the shaft torsional oscillations of synchronous generators in a multi-machine power system well.
- Minimization of shaft torsional oscillations by the fuzzy controlled braking resistor is affected by the communication delay.
- The negative effect caused by the communication delay on minimizing shaft torsional oscillations can be reduced by the proposed prediction method.

Future research will focus on the design of an adaptive fuzzy logic controller for BR by the application of genetic algorithm technique or other optimization technique. Moreover, we are interested in investigating another methodology of reducing the negative effect caused by the communication delay on minimizing shaft torsional oscillations. We

hope to publish our research results in the near future.

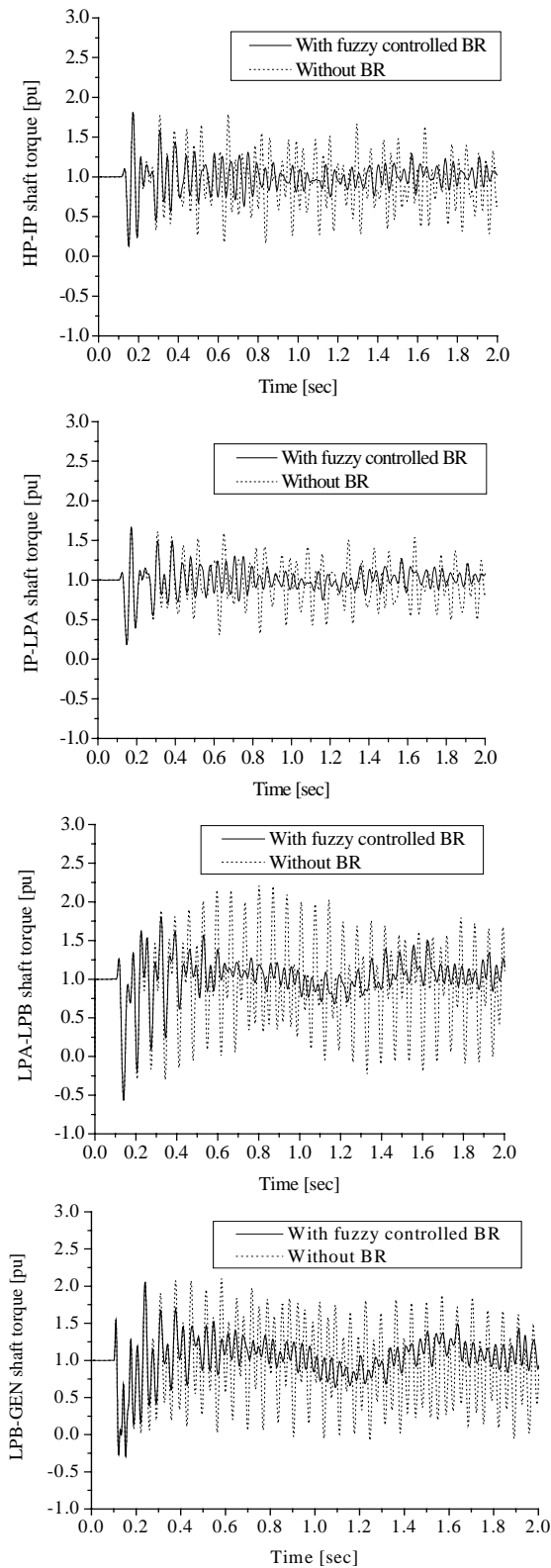

Fig. 6. Shaft torsional torque responses of generator G1 for 3LG fault at point A without considering communication delay.

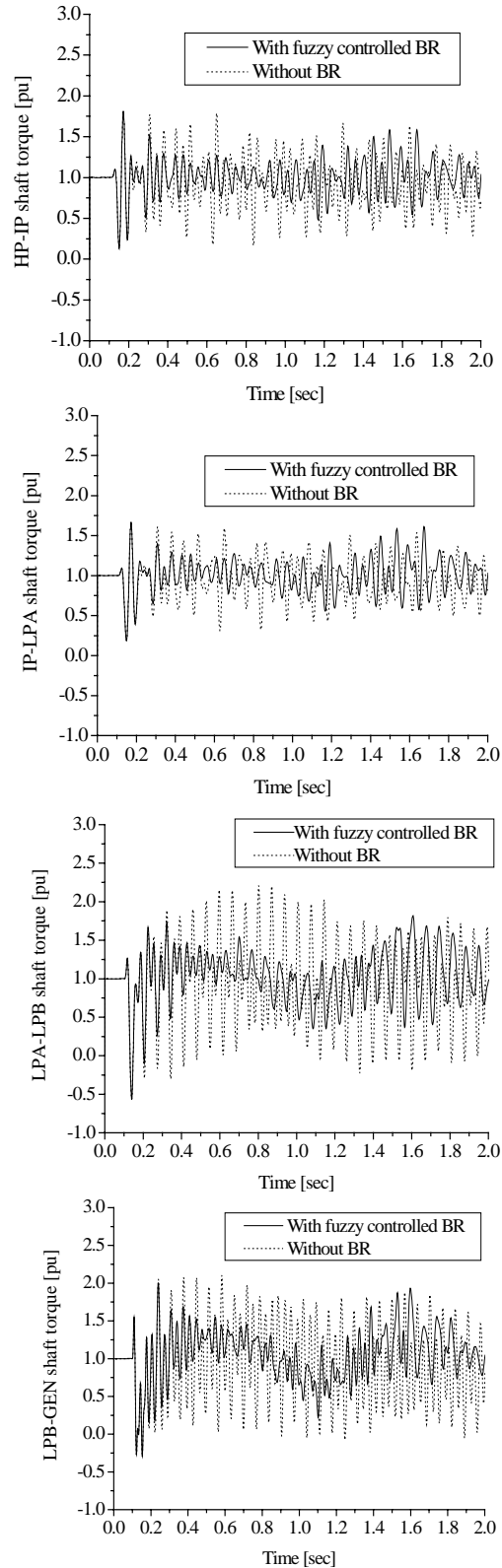

Fig. 7. Shaft torsional torque responses of generator G1 for 3LG fault at point A considering a communication delay of 20 msec.

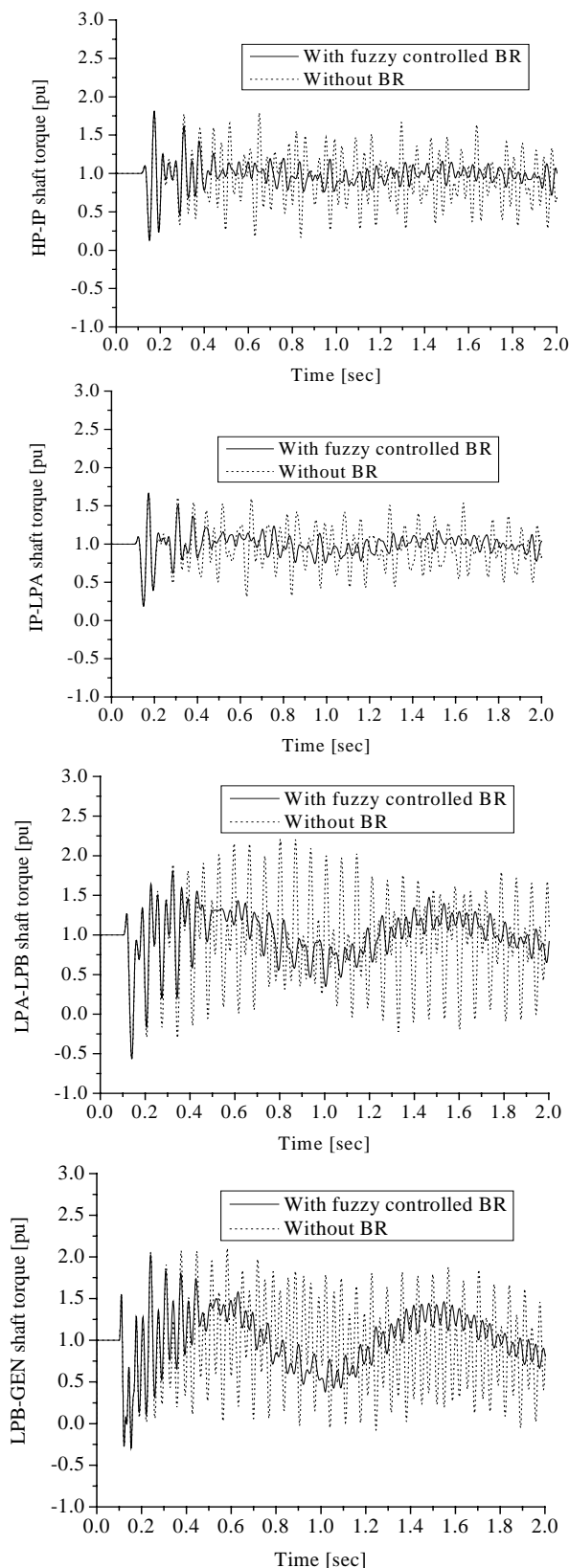

Fig. 8. Shaft torsional torque responses of generator G1 for 3LG fault at point A using prediction function method and considering a communication delay of 20 msec.

References:

- [1] P. Kundur, *Power System Stability and Control*, McGraw-Hill, Inc., 1994.
- [2] M. H. Ali, T. Murata, and J. Tamura, The Effect of Temperature Rise of the Fuzzy Logic-Controlled Braking Resistors on Transient Stability, *IEEE Transactions on Power Systems*, Vol.19, No.2, pp.1085-1095, May 2004.
- [3] M. H. Ali, Y. Soma, T. Murata, and J. Tamura, Transient Stability Improvement By Fuzzy Logic Controlled Braking Resistor, *International Journal of Power and Energy Systems*, Vol. 25, No.3, pp. 143-150, 2005.
- [4] M. H. Ali, T. Murata, and J. Tamura, Effect of Coordination of Optimal Reclosing and Fuzzy Controlled Braking Resistor on Transient Stability During Unsuccessful Reclosing, *IEEE Transactions on Power Systems*, Vol. 21, No. 3, pp.1321- 1330, August 2006.
- [5] R. Patel, T. S. Bhatti, and D. P. Kothari, A Modified Approach to Transient Stability Enhancement with Fast Valving and Braking Resistor Applications, *Electrical Power and Energy Systems*, Vol. 28, pp. 729-738, 2006.
- [6] M. K. Donnelly, J. R. Smith, R. M. Johnson, J. F. Hauer, R. W. Brush, and R. Adapa, Control of a Dynamic Brake To Reduce Turbine-Generator Shaft Transient Torques, *IEEE Transactions on Power Systems*, Vol. 8, No.1, pp. 67-73, February 1993.
- [7] A. H. M. A. Rahim and H. M. Al-Maghraby, Control of SSR Oscillations Through A Quasi-Optimum Dynamic Braking Strategy, *International Journal of Power and Energy Systems*, Vol. 23, No. 2, pp. 90-95, 2003.
- [8] A. H. M. A. Rahim, A Minimum-Time Based Fuzzy Logic Dynamic Braking Resistor Control for Sub-Synchronous Resonance, *Electrical Power and Energy Systems*, Vol. 26, pp. 191-198, 2004.
- [9] M. H. Ali, T. Mikami, T. Murata, and J. Tamura, A Fuzzy Logic Controlled Braking Resistor Scheme for Damping Shaft Torsional Oscillations, *IEEJ Transactions on Power and Energy*, Vol. 124, No. 2, pp. 207-214, February 2004.
- [10] M. H. Ali, T. Murata, and J. Tamura, Effect of Fuzzy Controlled Braking Resistor on Damping Turbine Generator Shaft Torsional Oscillations During Unsuccessful Reclosing, *International Review of Electrical Engineering (IREE)*, Vol. 1, No. 5, pp. 711-718, December 2006.
- [11] Working Group H-8 of the Relay Communications Subcommittee of the IEEE

- Power System Relaying Committee, IEEE Standard For Synchrophasors For Power Systems, *IEEE Transactions on Power Delivery*, Vol.13, No.1, pp.73-77, January 1998.
- [12] H. Y. Li, E. P. Southern, P. A. Crossley, S. Potts, S. D. A. Pickering, B. R. J. Counce, and G. C. Weller, A New Type of Differential Feeder Protection Relay Using the Global Positioning System for Data Synchronization, *IEEE Transactions on Power Delivery*, Vol.12, No.3, pp.73-77, July 1997.
- [13] C. W. Taylor, D. C. Erickson, K. E. Martin, R. E. Wilson, and V. Venkatasubramanian, WACS—Wide-Area Stability and Voltage Control System: R&D and Online Demonstration, *Proceedings of the IEEE*, Vol. 93, No. 5, pp. 892-906, May 2005.
- [14] X. Xie, J. Xiao, C. Lu, and Y. Han, Wide-Area Stability Control for Damping Interarea Oscillations of Interconnected Power Systems, *IEE Proc.-Gener. Transm. Distrib.*, Vol. 153, No. 5, pp. 507-514, September 2006.
- [15] F. Okou, L.-A. Dessaint, and Q. Akhrif, Power Systems Stability Enhancement Using a Wide-Area Signals Based Hierarchical Controller, *IEEE Transactions on Power Systems*, Vol. 20, No.3, pp.1465-1477, August 2005.
- [16] *EMTP Theory Book*, Japan EMTP Committee, 1994.
- [17] H. Ying, *Fuzzy Control And Modeling, Analytical Foundations and Applications*, The Institute of Electrical and Electronics Engineers, Inc., 2000.
- [18] D. Driankov, H. Hellendoorn, and M. Reinfrank, *An Introduction to Fuzzy Control*, Springer-Verlag, Berlin-Heidelberg, New York, 1993.
- [19] P. C. Chau, *Process Control, A First Course with MATLAB*. Cambridge University Press, 2002.
- [20] J. G. Balchen and K. I. Mumme, *Process Control, Structures and Applications*. Van Nostrand Reinhold Company, New York, 1988.
- [21] B. H. Zhang , Z. Q. Bo, Y. Z. Ge, R. K. Aggarwal, and A. T. Johns, The Design and Application of an Optimal Reclosure Technique for Transmission Lines, *1995 North American Power Symposium*, Montana State University, Bozeman, MT, USA, pp. 415-421, 1995.
- [22] M. Yagami, T. Murata, and J. Tamura, An Analysis of Optimal Reclosing for Enhancement of Transient Stability, *Electrical Engineering in Japan*, Vol. 147, No. 3, pp. 32-39, 2004.