

Renewable Energy Sources in Combined Systems - On-line System for Measuring and Collecting Data -

MASTNY PETR ⁽¹⁾, MATOUSEK ANTONIN ⁽²⁾, MACHACEK JAN ⁽³⁾

Department of Electrical Power Engineering
Brno University of Technology
Faculty of Electrical Engineering and Communication
Technicka 2848/8, 616 00 Brno
CZECH REPUBLIC

⁽¹⁾mastny@feec.vutbr.cz <http://www.ueen.feec.vutbr.cz/~mastny>

⁽²⁾matousek@feec.vutbr.cz, ⁽³⁾machacek@feec.vutbr.cz

Abstract: Research on the Department of Electrical Power Engineering FEEC, Brno University of Technology is among other things focused on the utilization of alternative power sources. The present situation within the field of power engineering positively encourages the research development of alternative power sources. Great attention is paid to increasing the efficiency and effectivity of power system operation. The paper presents results of the research in the field of alternative power sources utilization. It mainly points the possibilities of increasing the efficiency of alternative power sources operation by its mutual cooperation. Aspects of the cooperation are evaluated mainly from the energy point of view but the economic parameters of these systems are pointed as well. The paper also presents results of long-term measuring on active solar system connected into one unit together with a heat pump- the system has been installed in the university laboratories. The parameters of the measuring system that has been installed in the laboratories of the Department of Power Engineering are described as well.

The research proved that new approach to the cooperation of heat pump and solar system working in common power unit results in higher heating factor of a heat pump and high efficiency of a solar system which finally decreases prime energy demand. The conclusions presented in this paper started up thanks to the Grant Agency of the Czech Republic and the Ministry of Education of the Czech Republic.

Key-Words: solar system, combined heating system, heating factor, measuring system, heat pump, environment

1 Introduction

The aim of contemporary energy policy is mainly decreasing the consumption of primary power sources while keeping the growing energy production. Consequently the development and research is focused on increasing the efficiency of energy systems and on integration of renewable power sources into the energy production. Europe shows great interest in alternative power sources such as solar energy, heat pumps, wind energy etc.

Results of research within the field of utilization and application of renewable power sources presented in this paper establish new possibilities of cooperation of alternative power sources and therefore lead to increasing efficiency of its operation. Operation efficiency of renewable power sources is very important and fundamental issue for its further development.

The research gives answers to questions about possible cooperation of solar system and heat pump in common power unit. The result is the design of new conception of alternative power sources connection and based on the results of applied analysis it has more preferable operation parameters from the energy and economic

point of view than presently used systems. The paper also describes the measuring system used for on-line analysis and measuring on monitored energy unit.

2 Optimized connection of heat pump with solar system

At present within the technical field there appear common installations of active solar system and heat pump, however both systems in such connections work generally separately. This fact means that the systems have common storage reservoir and solar system „only“ increases the temperature of heating medium in the reservoir. [1, 3]

Disadvantage of such designed system is that the solar system has to work with the temperature of medium that is useful for heating (temperature on the input of heating system). This fact fundamentally lowers the efficiency of solar system itself during winter time. Another disadvantage of the system described above is its price. Whole system has to be over-dimensioned which is the cause of higher costs. Over-dimensioning also results in a very long payback period caused by improper usage of

solar panels over the year namely thanks to both the high output temperature and insufficient (fluctuating) value of solar radiation intensity. The main contribution of optimized connection is high operational efficiency of solar system and increased heating factor of heat pump. These facts influence positively decreasing the consumption of primary energy necessary for operation of heat pump.

In the system there is used the combined solar collector which provides to use air and water as heat carrier. This appears as a great advantage. The optimization is realized on the system assembled thanks to grant support of Ministry of Education. Functional model of air-to-air heat pump together with added solar system has been assembled so the original hypothesis of proper cooperation of these power sources. Optimized system (see Fig. 1) works on following principle.

- During the heating season the solar system is activated when the temperature falls below the temperature of bivalent. The solar system is then used for increasing the temperature at the heat pump input. Increasing the input temperature causes increasing the heating factor of whole system and at the same time it lowers the demands on primary energy necessary for heat pump operation.
- Solar system is used for heating water beyond the heating season. Combined solar collectors allowing fluent conversion between heat carriers (air and water) are used.

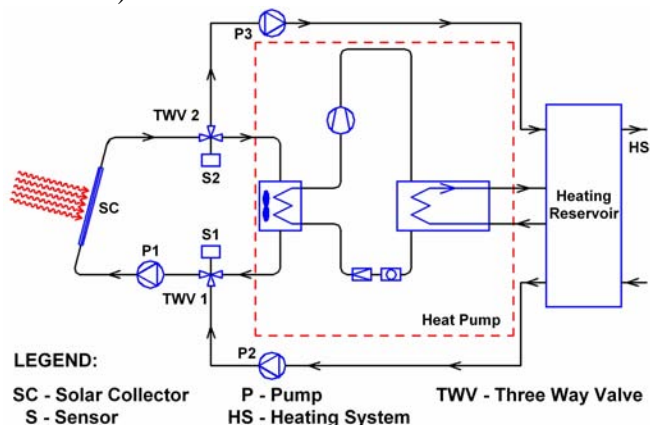

Fig. 1 [1, 2]

The basic idea is to use the solar system for pre-heating the input medium (air) of heat pump during the heating season and therefore achieve better operational parameters of the system. The presumption is the input temperature increase within the limits of $\Delta T = 5 - 10^{\circ}\text{C}$. Within the applied research there is for the defined input temperature gradient determined the optimal area of added solar system and its direct influence on heating factor. The area of solar system is determined on the basis of applied analysis of measured data on combined system of heat pump (air-to-water) and allocated solar

system and on the basis of long-term measuring of solar radiation intensity in Brno, Czech Republic. Evaluation of combined system is completed on the basis of energy-economic analysis of the operation.

2.1 Results of measuring on combined system

Bivalent source in designed connection (see Fig. 1) is solar system. The primary task is to determine the operational parameters (such as efficiency, temperature gradients, operating temperatures) of solar system for required working conditions. The demand is increase the temperature of heat carrier within the limits of $\Delta T = 5 - 10^{\circ}\text{C}$. To determine these parameters it is essential to ensure long-term measuring of operation states. It is very important to determine the distribution of solar radiation intensity during the day for area in view. For this purpose the methodics based on period of sunshine is used. Information about sunshine serve as input data for setting radiation characteristics.

This method consists in determining the average month amount of global, diffusion and direct insolation. After determination of these characteristics it is possible to provide daily amount and subsequently average daily behaviour of global, diffusion and direct insolation flow. The figures 2 and 3 show behaviour of solar radiation intensity for monthly (December and January) middle days. For each day there is marked out average air temperature T_{ave} and average intensity of solar radiation I_{ave} . [4, 1]

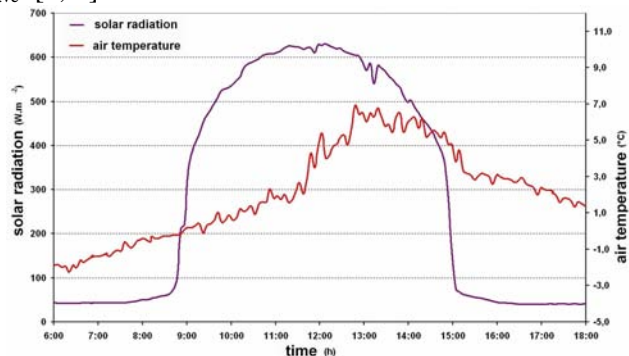

Fig. 2 Behaviour of solar radiation intensity in December 2005

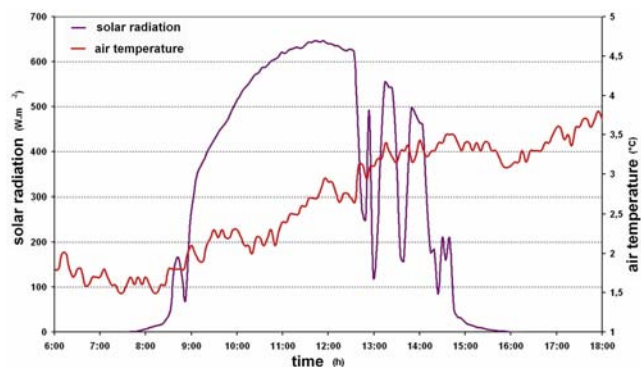

Fig. 3 Behaviour of solar radiation intensity in January 2006

According to provided temperature rise of input medium in heat pump ($\Delta T = 5 - 10^\circ\text{C}$) there is the average

efficiency of solar system η_{ave} determined. Measured and calculated values are mentioned in Table 1.

month	day	T_{ave}	I_{ave}	T_{A1}	T_{A2}	T_{A3}	$\eta_{1\text{ave}}$	$\eta_{2\text{ave}}$	$\eta_{3\text{ave}}$
		$^\circ\text{C}$	$\text{W}\cdot\text{m}^{-2}$	$T_{\text{ave}} + 5^\circ\text{C}$	$T_{\text{ave}} + 8^\circ\text{C}$	$T_{\text{ave}} + 10^\circ\text{C}$	%	%	%
December	16.12.2005	2,1	292	7,1	10,1	12,1	75	69	64
January	16.1.2006	2,7	336	7,7	10,7	12,7	76	71	67

T_A – temperature of air at output of solar system

Table 1

3 System for measuring and Collection of data

Regarding research of cooperation of heat pumps with solar collectors there has been developed automatic measuring system within the research project. Basic information about the system have been presented on the RES'07 conference in France, October 2007.

Measuring system was originally developed only for measuring the intensity of solar radiation and temperature but considering great progress in using renewable power sources the system has been upgraded also for measuring on photovoltaic panels.

The fundamental reason for upgrading the measuring system is great development of alternative power sources – mainly photovoltaic panels – in the Czech Republic. During a year-long period there has been installed 800% higher performance of photovoltaic systems working into power system of the Czech Republic (0,5 MWp in 2006 – 4,3 MWp in October 2007).

Following text describes the system for measuring and collecting data from the solar collectors.

Functionality of measuring system was experimentally verified in the laboratories of the Department of Electrical Power Engineering, VUT in Brno. For the verification there has been used photovoltaic panel with rated capacity $P_N = 100 \text{ Wp}$.

It is necessary to mention that very the measuring system described bellow was used for decisive experimental measuring on new concept of connection of heat pump and solar system. And also thanks to this measuring system it is possible to specify advantages and disadvantages of newly assembled combined system and to define optimal energy and economic characteristics of operation of combined system.

3.1 Structure of the measuring system

Measuring system monitors following characteristics:

- intensity of solar radiation
- instantaneous panel power
- air temperature
- temperature of photovoltaic panel

To have the full picture, we also measure the temperature of the bottom (non-illuminated) side of the

panel. Both the real and the optimized instantaneous panel power are measured. The real power is measured in the usual PV panel – accumulator connection.

3.2 Principle of measuring and connection

The data being measured is transferred, using a separating multiplexer, from nine sensors (see Fig. 4) into a measuring system formed by the NI-6023E plug-in card. Signals from all the measuring sensors are conveyed in a defined time loop to the analog inputs of the measuring card. The card will digitize this data and forward the rough data to the control program (in the Matlab script). This script not only communicates with the measuring card, thus controlling the whole measurement but, in addition, it controls the run of the optimization circuit via the digital outputs of the card. To enable the data to be archived in a clear way and to be further processed, the data is sent by the script to the MySQL database on the server, and the whole loop is repeated. The data held in the databáze can be further processed independently of the measurement in progress, i.e. sorting and additional calculations can be performed. Data modified and prepared in this way can be presented on-line on the Internet practically in real time.

More detailed description of each part of measuring system and its control programme is pointed in [3].

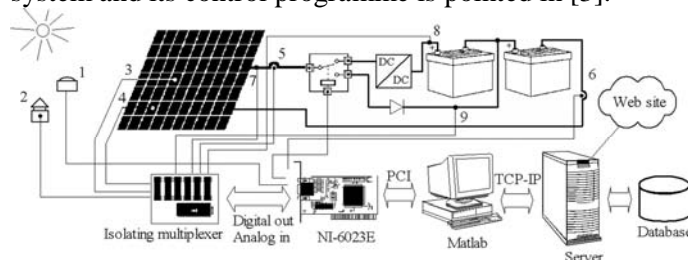

Fig. 4 Connection and positron of measuring sensor

3.3 Evaluation of measuring

Saving the data measured into the database is not enough, it has to be processed. This means conducting complementary calculations (if need be), sorting the data, evaluating the results, and displaying them.

In our case we perform several complementary calculations. For example for the powers measured,

intensity of incident solar radiation and temperatures we also calculate:

- daily energy generated by the panel,
- cumulative and instantaneous efficiency of the energy conversion by PV panel,
- monthly summarization of energy generated by the panel and next.

The above calculations, their results, graphs, and further complementary information are given on the web pages of our laboratory.

An advantage can be seen in that the presentation of measuring results has been conceived in such a way that it is possible to display not only the measuring just taking place but also the history of all the measurements that have been conducted for a given task. Examples of the graphs of measured and calculated values are given in the following Figures.

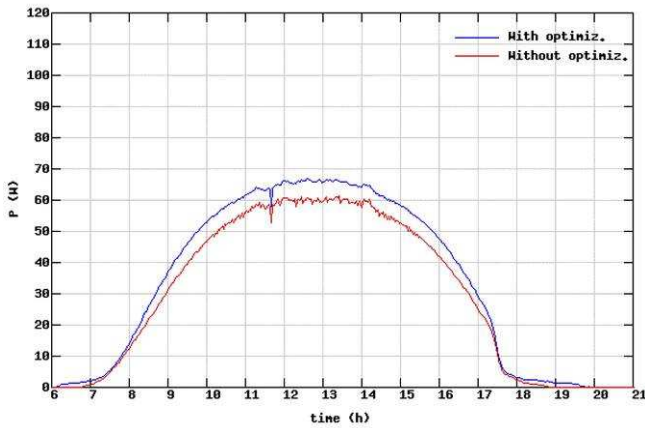

Fig. 5 Power characteristic of PV panel

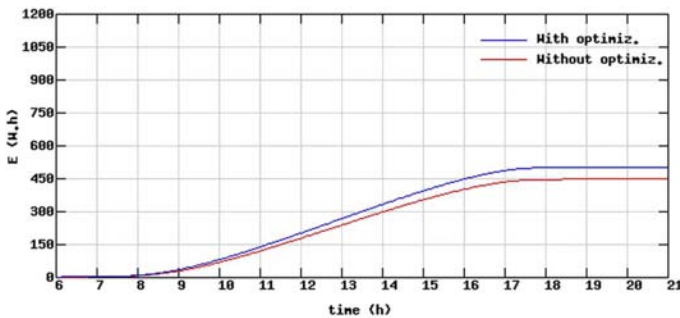

Fig. 6 Daily energy generation

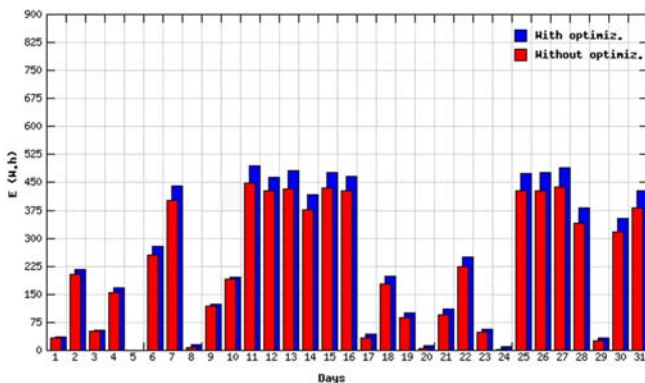

Fig. 7 Course of power generation on March 2007 [3]

4 Evaluation of influence of sources cooperation on heating factor

As the results of measuring proved, the added solar system in combined connection has positive influence on operational characteristics of heat pump mainly on its heating factor. This fact is most apparent in Figure 8.

The picture presents percentage growth of heating factor (Δ COP) which is valid for particular area of added solar system $S = 10, 14, 20$ and 24 m^2 .

Operational characteristics pointed in Figure 9 explain the influence of added solar system on heating factor. Characteristics are valid for the output temperature from the heat pump $T_{\text{out}} = 16^\circ\text{C}$ and the parameter of each course is the area of added solar system ($S = 10, 14, 20$ and 24 m^2).

Introduced heating factor COP (*Coefficient of Performance*) result from real energy flows measured on combined system and it is determined according to the equation pointed below (1).

$$COP = \frac{\Delta T \cdot Q_m \cdot C_p}{P_p} \quad (-) \quad (1)$$

4.1 Evaluation of combined system operation

Economical-technical evaluation of operation of combined heat pump and solar system is based on the analysis of operational parameters. Energy evaluation results from measured values on the combined system.

Economical evaluation is an integral part of the general evaluation.

The result of economical-technical analysis is to find the optimal area of solar system for increasing the medium temperature on the input of the heat pump in required range $\Delta T = 5 - 10^\circ\text{C}$.

To compare heating with the heat pump and other possible power sources, the existing family house project in Brno is used. The newly built-up low-energy house of $8,4 \text{ kW}$ heat loss and of $Q_{\text{anecd}} = 22,4 \text{ MWh}\cdot\text{year}^{-1}$ total energy demand (heating - $Q_{\text{Heat, year}}$ and hot service water $Q_{\text{HW, year}}$).

For evaluation of proper connection and possible cooperation of these sources the heat pump air to water with rated thermal capacity of $5,3 \text{ kW}$ has been used.

The heat rate of heat pump at the temperature of primary source 2°C and output temperature 35°C is $P_t = 5,8 \text{ kW}$ and heating factor $\epsilon = 3,6$. The type of the heat pump is designed so the ratio of heat pump performance to heat loss of the building is 63% that correspond to 90% of supplied thermal energy for heating the building [2].

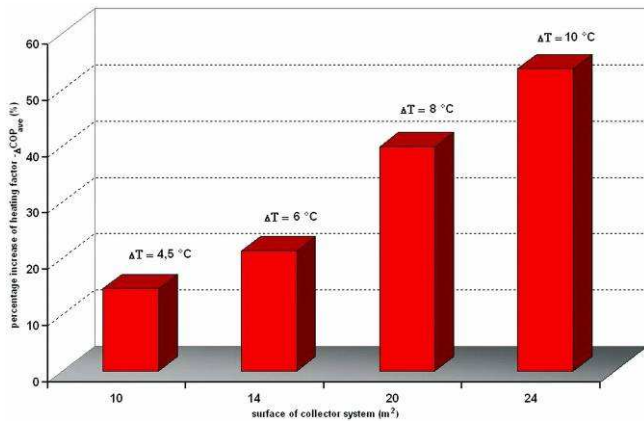

Fig. 8 Percentage increase of heating factor [1]

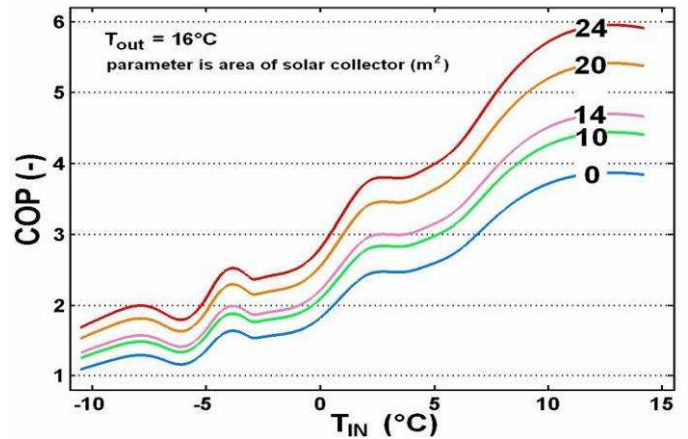

Fig. 9 Influence of added solar system on heating factor

The remaining thermal energy necessary for heating and hot service water is ensured by the cooperation of heat pump and solar system. As it is mentioned above, the solar system is for a fraction of a year used as a bivalent power source to the heat pump where it increases the temperature at the input of the heat pump. In this case air is the working medium. In case it is not necessary to increase the heat pump performance then the solar system is used for heating hot service water. Water is the working medium in such case.

Very important issue when regarding operation of the system is the comparison of yearly costs of heating for newly assembled combined system and for system using common connection of heat pump - see [1, 5]. The advantage of combined system can be seen in Figure 10. As it is mentioned in the beginning of this paper, the heat demand for the monitored building is 17,0 MWh.year⁻¹ and the heat demand for heating hot service water is 5,4 MWh.year⁻¹. The heat pump covers the heat demand up to 90% which conform to 15,3 MWh.year⁻¹. To cover the entire heat demand for heating and hot service water it is necessary to supply 7,1 MWh.year⁻¹ from the solar system. Economical-technical evaluation regards the energy demands of the building and the economic parameters as well. The results of the analysis are presented in the Figure 11.

The results clearly define the possibility and the field of energy and economic usage of a solar system in connection with a heat pump for monitored building with total heat loss $Q_c = 8,4$ kW determined on the basis of average monthly values of solar radiation intensity measured in the laboratories of Unconventional Transformations at the Department of Electrical Power Engineering, Brno University of Technology, Czech Republic.

The analysis of operation of combined system (its graphic visualization can be seen in Fig. 11) has been from the energy and economic point of view described in the paper presentation on the RES'07 conference in France

and it also has been published in the conference proceedings [5] and in the scientific proceedings of Brno University of Technology [1]

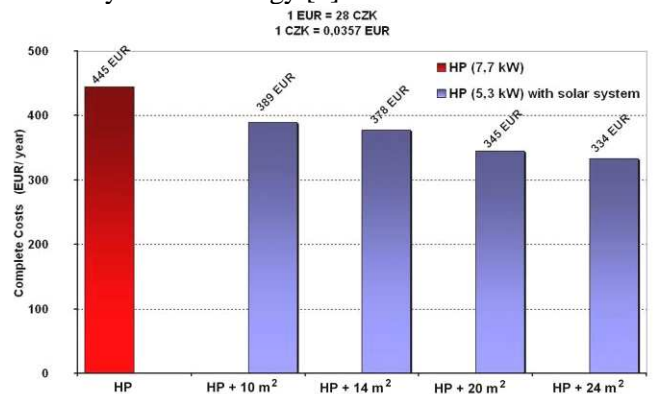

Fig. 10 Confrontation of operating costs

5 Conclusion

The results of the research pointed in this paper, which is focused on increasing the efficiency of operation of alternative power sources, present new possibilities of alternative power sources cooperation. The research is focused on the cooperation of active solar systems and heat pumps. As the presented results explain, the cooperation of these sources is well-founded from the energy and economic point of view. In comparison with presently used system, the new connection of these sources is much more effective. Solar collectors in the new connection work with high efficiency which moves around 70%. The reason for such favourable operational parameters is mainly the new system of connection. Another important result is high heating factor of cooperating heat pump. The measuring system has been designed for the purpose of measuring on the assembled combined system. The measuring system allows on-line monitoring of measured characteristics on both the solar system and the heat pump.

Measuring system is at present used for analysis of influence of operating conditions of solar energy convertors with optimization of its charge during full operation. The research is still focused on verifying and upgrading the functions of the system. Obtained great amount of data allow calculations for which a long-term measured data are required. Great advantage of the measuring system is its simplicity and easy modification on different measuring assignments.

The essential contribution of this research is the increase of operational efficiency of combined system. This fact has direct influence on the consumption of prime energy of combined system. New connection allows to use heat pump with lower load which decrease the consumption of prime energy. This fact positively influences reducing the CO₂ concentration. It is true that present world-wide

interest in broader utilization of renewable power sources greatly encourages its development but it is essential to understand that such power sources cannot be applied in all localities. Renewable power sources have its specific character and it is necessary to pay attention to it regarding practical installations. It is proper to ask a question whether the renewable power sources could solve the energy demands of mankind and whether there are proper conditions for its usage all over the world. Surely not but renewable power sources have its steady position in the energy conceptions of EU member states and other countries.

The whole research follows the demands of the EU on the usage of alternative power sources. And it is supported by the Ministry of Education of the Czech Republic.

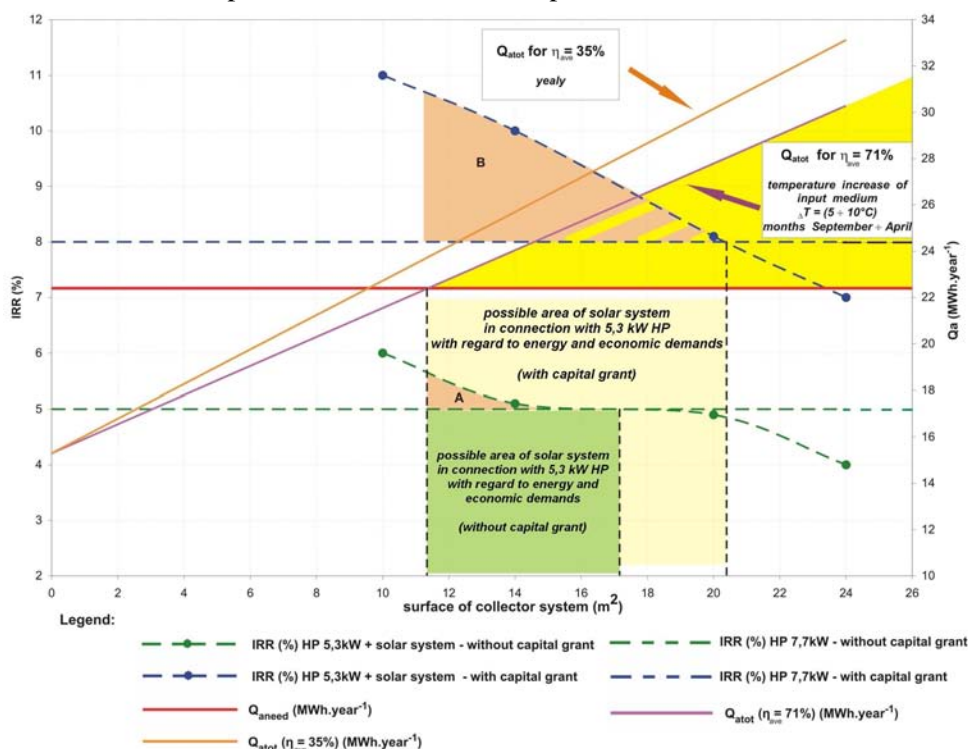

Fig. 11 [1, 2]

Acknowledgments:

This paper contains the result of research works funded from project No. MSM0021630516 of the Ministry of Education, Youth and Sports of the Czech Republic.

References:

[1] Mastny, P. *Tepelná čerpadla v kombinovaných tepelných systémech*. Scientific tracts Brno University of Technology, Edice PhD Thesis, sv. 392, ISSN 1213–4198, Brno 2006

[2] Mastny, P. *Cooperation of Heat Pump and Solar System in the Common Power Unit*. WSEAS - Proceedings of the WSEAS International Conferences: EE'07, Slovenia, ISSN 1790-5095, 2007, roč. 1, č. 1, s. 186 - 194

[3] Machacek J., Prochazka Z., Drapela J. *System for Measuring and Collecting Data from Solar-cell Systems*. 9th International Conference Electrical Power Quality and Utilisation, Barcelona, October 2007, ISBN: 978-84-690-9441-9

[4] Mastný P., *Tepelná čerpadla v kombinovaných tepelných systémech*. Dissertation Thesis, FECC BUT Brno, Brno 2006

[5] Mastny, P.; Matousek, A. *Increase of Efficiency of Energy System with Heat Pump Using Solar Radiation*. Energy and Environment Proceeding of the RES'07, Arcachon, France, October 14 16, 2007: ISBN: 9789606766091.