

Mobile Satellite Antenna Tracking System Design with Intelligent Controller

PO-KUANG CHANG, JIUM-MING LIN

Institute of Technology and Science

Chung-Hua University

707, Sec. 2 Wu-Fu Rd., Hsin-Chu, Taiwan, 30012

REPUBLIC OF CHINA

puppy@itri.org.tw, jmlin@chu.edu.tw

Abstract: - This research applied an intelligent controller for mobile satellite antenna tracking system design. The intelligent controller is with both the traditional PI and the fuzzy control methods. The antenna tracking and the stabilization loops were designed firstly according to the bandwidth and phase margin requirements. However, the performance would be degraded if the tracking loop gain is reduced due to parameter variation. On the other hand a PD type of fuzzy controller was also applied for tracking loop design. It can be seen that the system performance obtained by the fuzzy controller was better for low antenna tracking gain. Thus this research proposed an intelligent controller by taking both traditional PI and fuzzy controllers for antenna tracking system design with appropriate weighting factors. The results show that the performances are better, and the tracking gain parameter variation effect can be reduced.

Key-Words: - Antenna tracking loop, Stabilization loop, Fuzzy controller, PI compensator, Intelligent controller

1 Introduction

In order to cope with the satellite Ka-band and broadband mobile communication requirements, the capacity is five times of Ku-band before. The mobile antenna needs to lock on the satellite in spite of disturbances, thus the performances of antenna tracking as well as stabilization loops of Ku-band should be raised [1-3], and e.g. the tracking rate, pointing precision as well as stabilization should be upgraded. The traditional PI (Proportion and Integration) compensator was applied for the tracking and stabilization loops design of mobile antennas to lock on the satellites [4]. The fuzzy controller was applied for the tracking loop design [5], and the relationship functions of Gaussian distribution were applied for six degrees of freedom simulation, thus the computation loading was very large. The noise and wind disturbance was taken into antenna design consideration [6].

This research applied an intelligent controller for mobile satellite antenna tracking system design. The intelligent controller is with both the traditional PI and the fuzzy control methods [6-10] for mobile antenna tracking system design and performance analysis. Firstly, the antenna tracking and the stabilization loops were designed with the traditional method according to the bandwidth and phase margin requirements. This research used a

simplified model for the antenna control system design, and made the time and frequency domain analyses to obtain the key parameters of antenna tracking and stabilization loops. The stabilization loop was designed by using proportion and PI compensators for comparison. It was found that the performances obtained by PI compensation method was better for both time and frequency domain responses. However, if taking the tracking loop gain degradation effect into consideration [11], the performances obtained by using a PD type fuzzy controller were better.

Thus this research proposed an intelligent method by taking both traditional and fuzzy controllers for antenna tracking system design with different weighting factors. The results show that the performances are better, and the tracking gain parameter variation effect can be reduced.

The organization of this paper is as follows: the first section is introduction. The second one is for traditional design of antenna tracking and stabilization loops. The antenna performance analyses with a traditional and a fuzzy controller design are given in Sections 3 and 4. The integration method by taking both traditional and fuzzy controllers for antenna tracking system design and performance analyses is given in Section 5. The last part is the conclusions.

2 Additional Design Of Antenna Tracking and Stabilization Loops

The detailed block diagram of a satellite antenna tracking system is shown in Fig. 1, in which both tracking and stabilization loops as well as pitch, roll and yaw coupling effects are taking into consideration. It is very difficult to obtain the key parameters for analyses and simulation. Thus in general a simplified model of antenna pitching or yawing control system is applied to speed up the design and obtaining the key parameters, in which the tracking loop is modeled as a simple gain, and the stabilization loop is replaced by a pure integration, or a PI compensators as in Figs. 2 (a) and (b).

Finally, the full model is applied in the six degrees-of-freedom simulation for practical verification.

This section is for antenna tracking and stabilization loops design with the traditional control method. Since the pitch channel and yaw channel are symmetry that this paper makes only one channel design. The stabilization loop design and analyses applies two kinds of structure, i.e., pure integration and PI compensators as shown in Figs. 2(a) and 2(b).

2.1 Stabilization loop design with pure integration

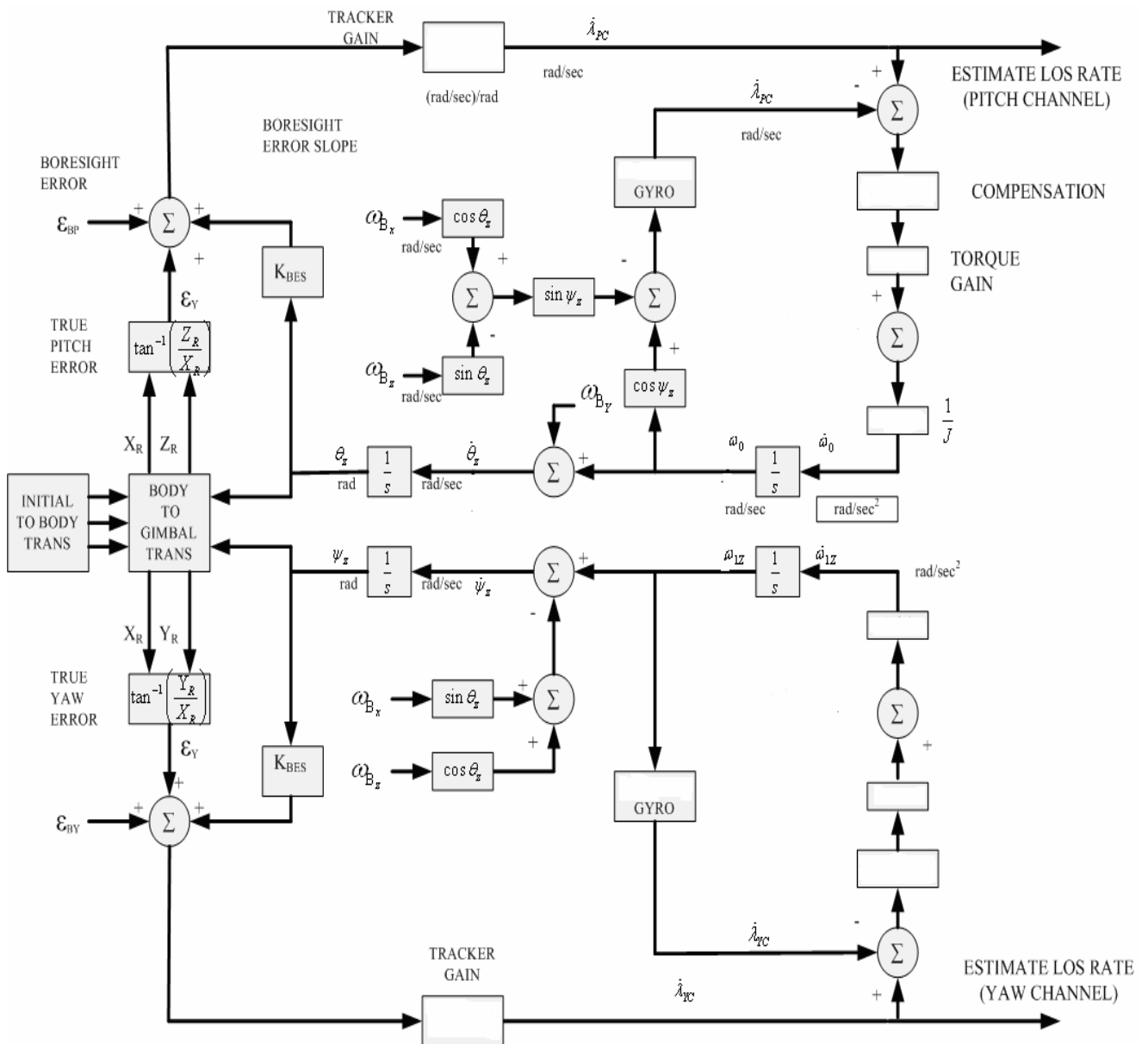

Fig. 1 The detailed block diagrams of antenna tracking and stabilization loops.

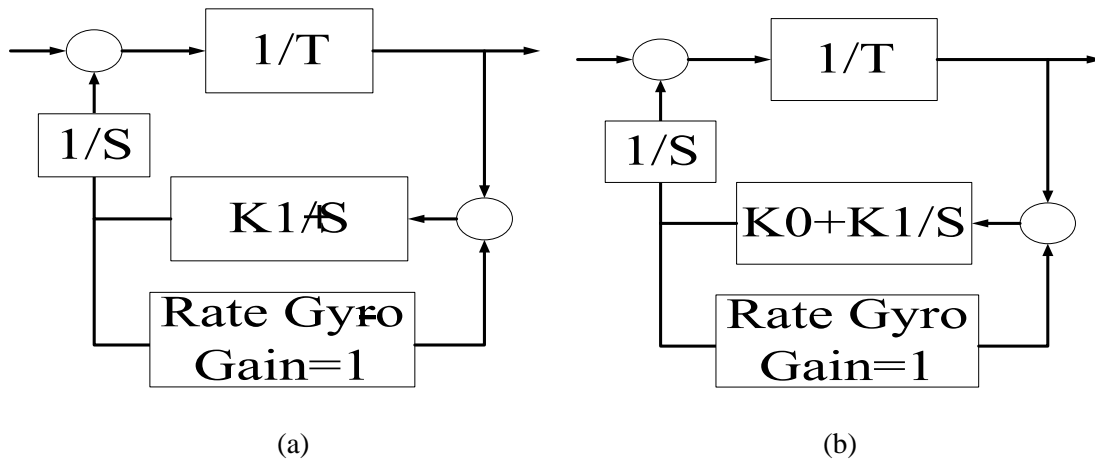

Fig. 2 Simplified block diagrams of antenna pitching or yawing control systems for the stabilization loop applying (a) pure integration, and (b) PI compensators.

Let the integrator gain (K_1) of stabilization loop be 25, 50, 75 and 100, respectively, the Bode plots are in Fig. 3. The gain margins are ∞ . Although the phase margin is increased with larger K_1 , the increasing rate is saturate for the case of $K_1=100$.

2.2 Stabilization loop design with PI compensator

In this section the stabilization loop design is with PI compensator. The gains of the proportion and integra-

tion terms are denoted as K_0 and K_1 , respectively. Fig. 4 shows the Bode plots for several K_0 's with the tracking loop time constant $T=0.1$ and the stabilization loop gain $K_1=100$. It can be seen in Fig. 5 that the phase margin is insensitive with K_1 ($T=0.1$ and $K_0=5$), but in this case the steady-state error can be eliminated. By some trial-and-error one can see that the phase margins are larger (132° and 133°) for the cases with $K_0=5$, $K_1=50$, $T=0.1$ and $K_0=5$, $K_1=25$, $T=0.2$, respectively. The latter is chosen for the requirement of faster time response.

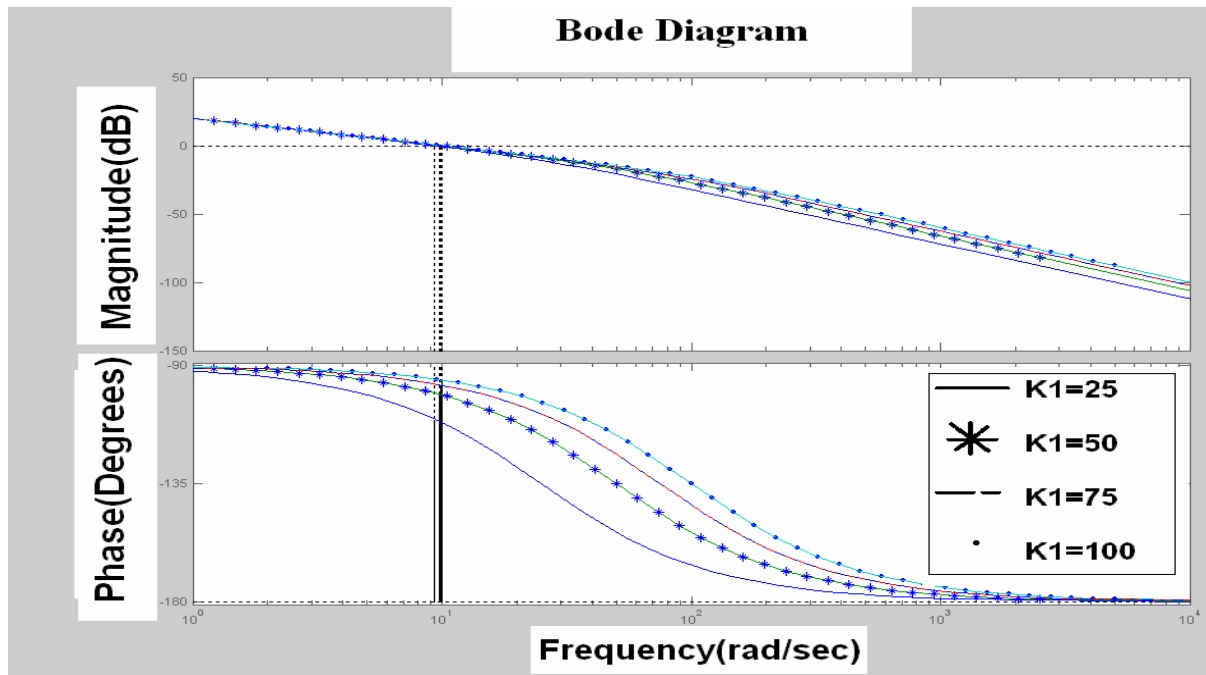

Fig. 3 Bode plots for K_1 are as 25, 50, 75 and 100, respectively.

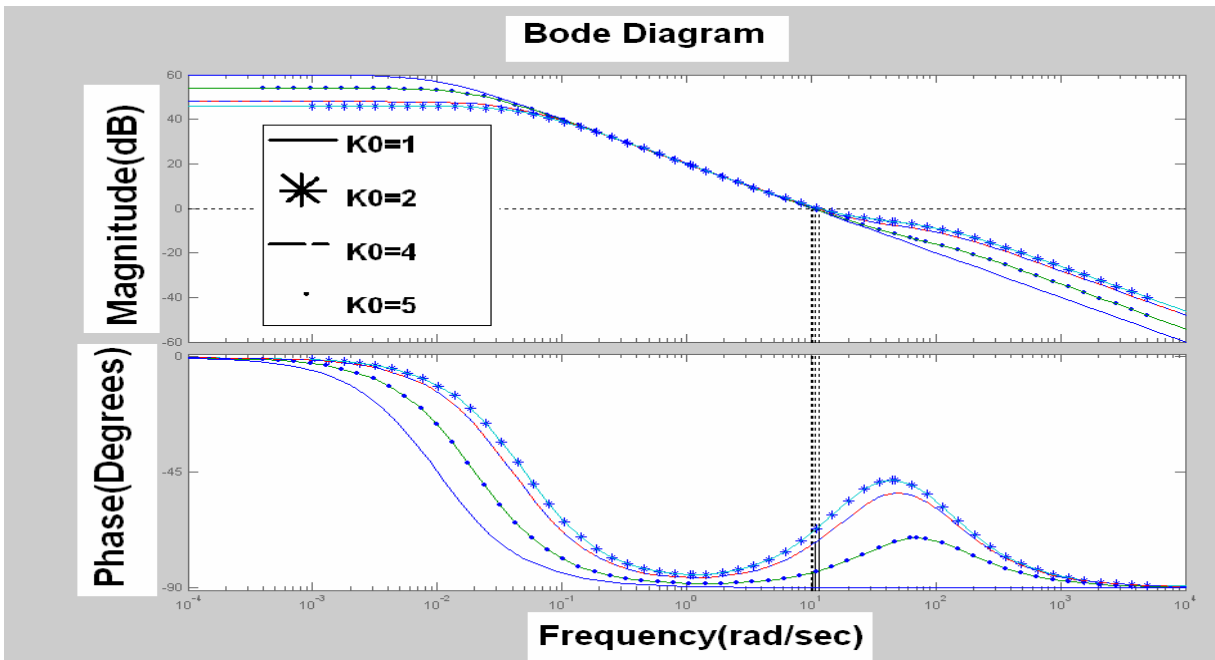

Fig. 4 Bode plots for several K_0 's with $T=0.1$ and $K_1=100$.

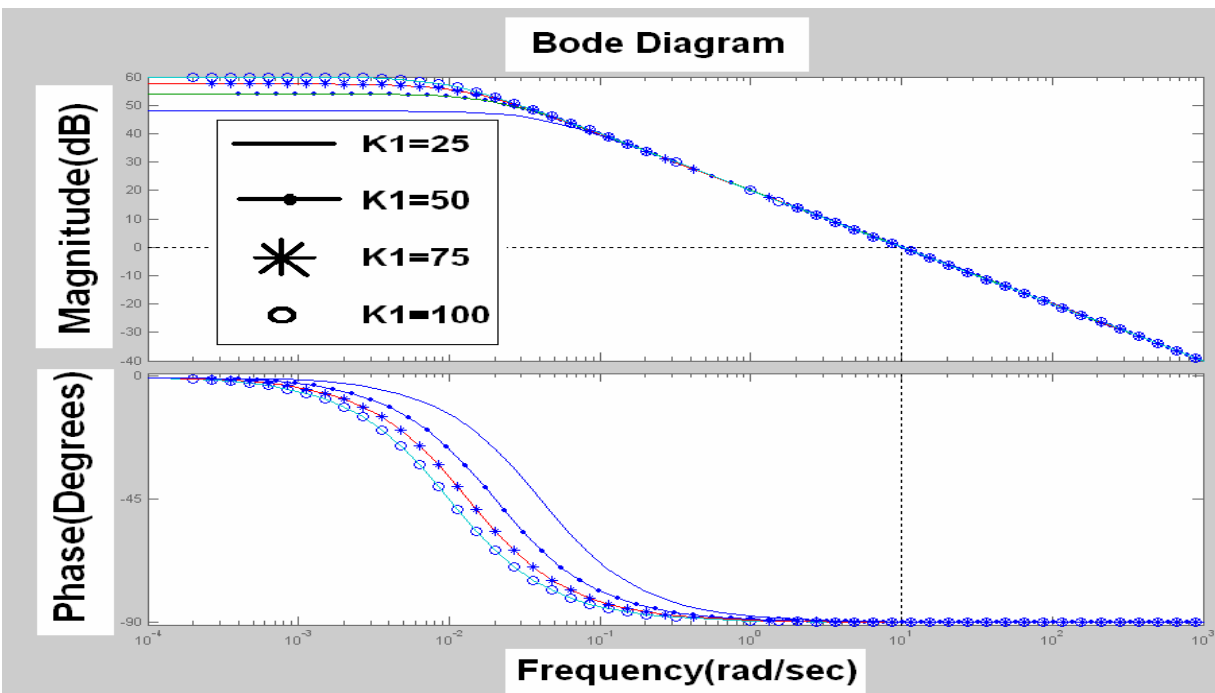

Fig. 5 Bode plots for several K_1 's with $T=0.1$ and $K_0=5$.

3 PI controller performances analyses

In this section the antenna performance is analyzed by simulation as in Fig. 6. The input line-of-sight angle is a triangle one with amplitude and period respectively as 1 radian and 5 seconds in Fig. 7. Noted that the gimbal angle in Fig. 8 can track with the input of line-of-sight

angle, and the performance is very good. In reality there is tracking loop gain parameter variation effect. The simulation results with this effect are shown in Figs. 9-10 for the parameter T changing from 0.1 to 1 and 1.5, respectively. It can be seen that the tracking performances are reduced. Thus the traditional method would not be applied for the systems with lower tracking loop gains.

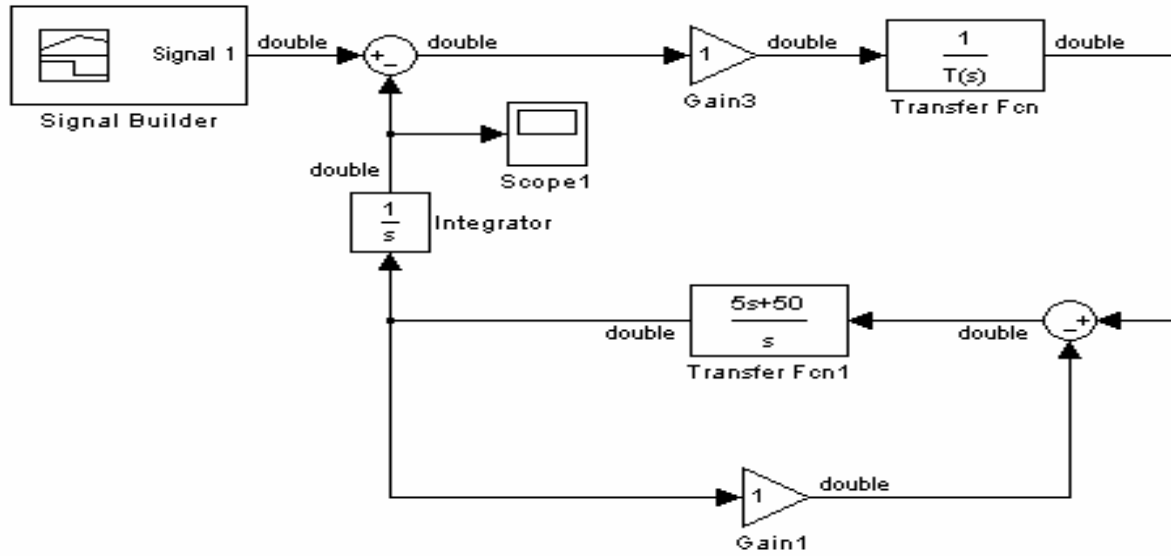

Fig. 6 Antenna performance analyses with traditional design.

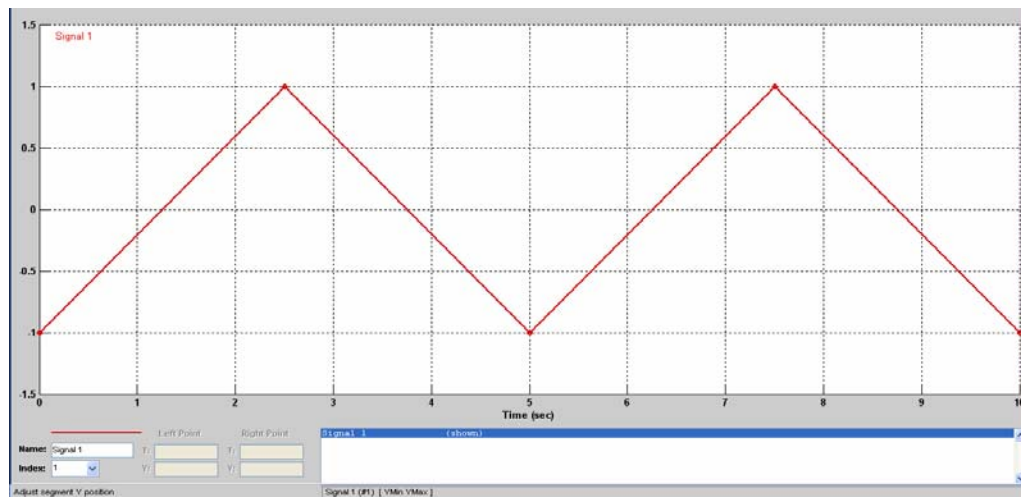

Fig. 7 Triangular input line-of-sight angle with amplitude 1 radian and period 5 seconds.

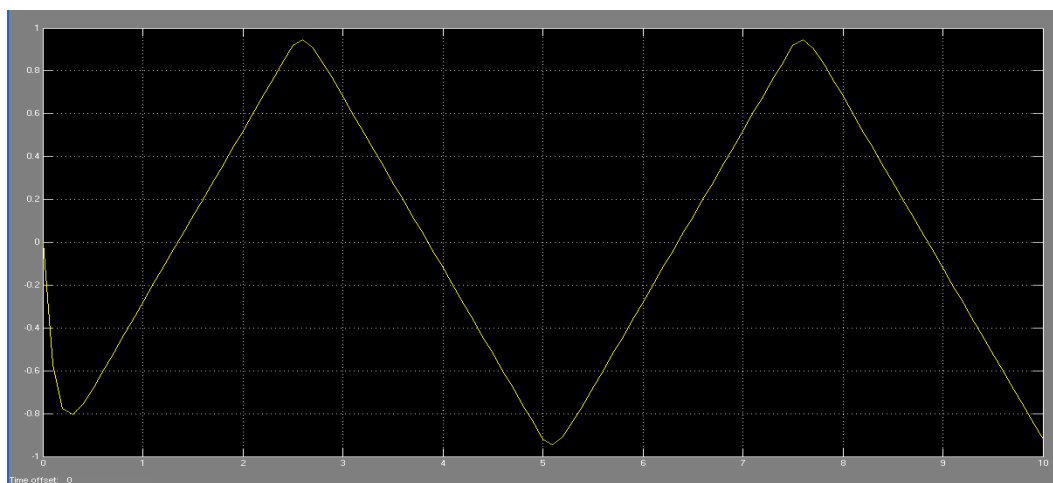

Fig. 8 Gimbal angle output obtained by traditional design with $T=0.1$.

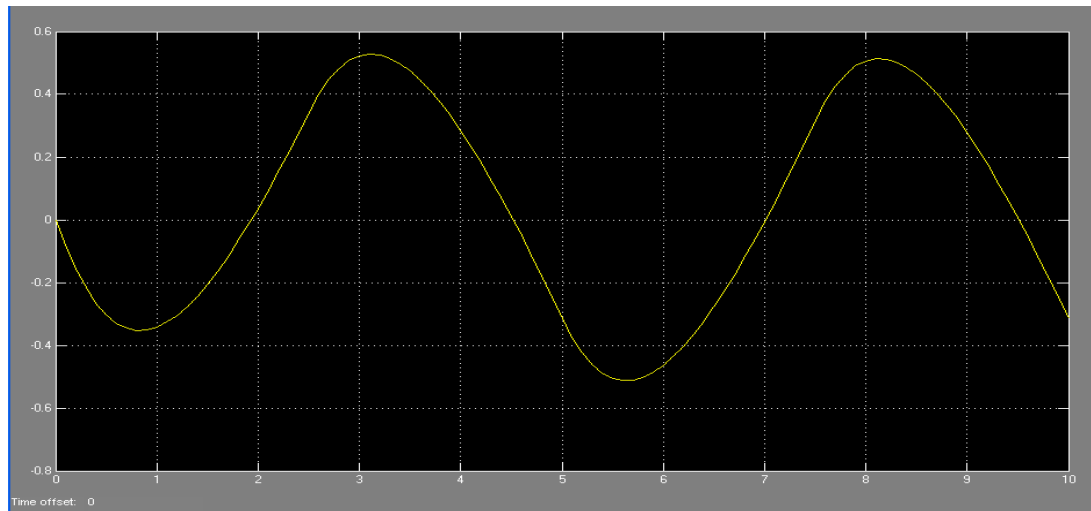

Fig. 9 Gimbal angle output obtained by traditional design with $T=1$.

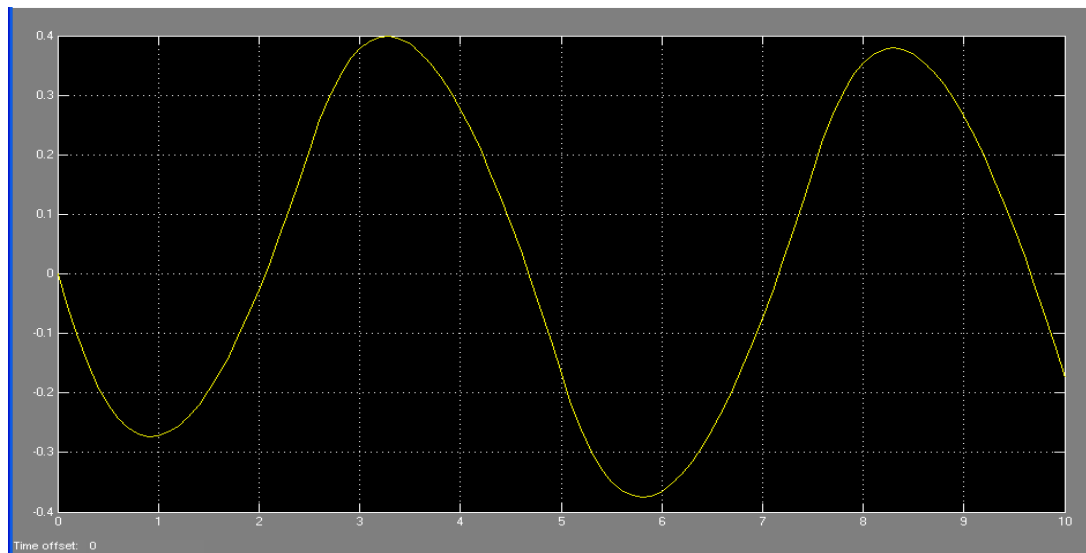

Fig. 10 Gimbal angle output obtained by traditional design with $T=1.5$.

4 Fuzzy controller design & analyses

4.1 Fuzzy controller design

In this section a Proportion and Derivative (PD) type fuzzy control design method [8-10] is applied in the tracking loop as in Fig. 11. It is well-known that the fuzzy controller is based on the following IF-THEN RULE, e. g.

- R1 : IF E is NB AND ΔE is NB THEN U is NB,
- R2 : IF E is NB AND ΔE is ZE THEN U is NM,
- R3 : IF E is NB AND ΔE is PB THEN U is ZE,
- R4 : IF E is ZE AND ΔE is NB THEN U is NM,
- R5 : IF E is ZE AND ΔE is ZE THEN U is ZE,
- R6 : IF E is ZE AND ΔE is PB THEN U is PM,

- R7 : IF E is PB AND ΔE is NB THEN U is ZE,
- R8 : IF E is PB AND ΔE is ZE THEN U is PM,
- R9 : IF E is PB AND ΔE is PB THEN U is PB,

where NB, NM, NS, ZE, PS, PM, and PB respectively stand for negative big, negative middle, negative small, zero, positive small, positive middle, and positive big. The detailed cross reference rules for the inputs and output of fuzzy controller are defined in Table I. According to the fuzzy control design method the relationship functions of boresight error E , ΔE (deviations of present E and the previous E), and U (control input) are defined at first, which are listed in Tables II-IV. The relationship functions in Tables II-IV are with triangular functions (Trimf) and trapezoidal functions (Trapmf) to reduce the computation time.

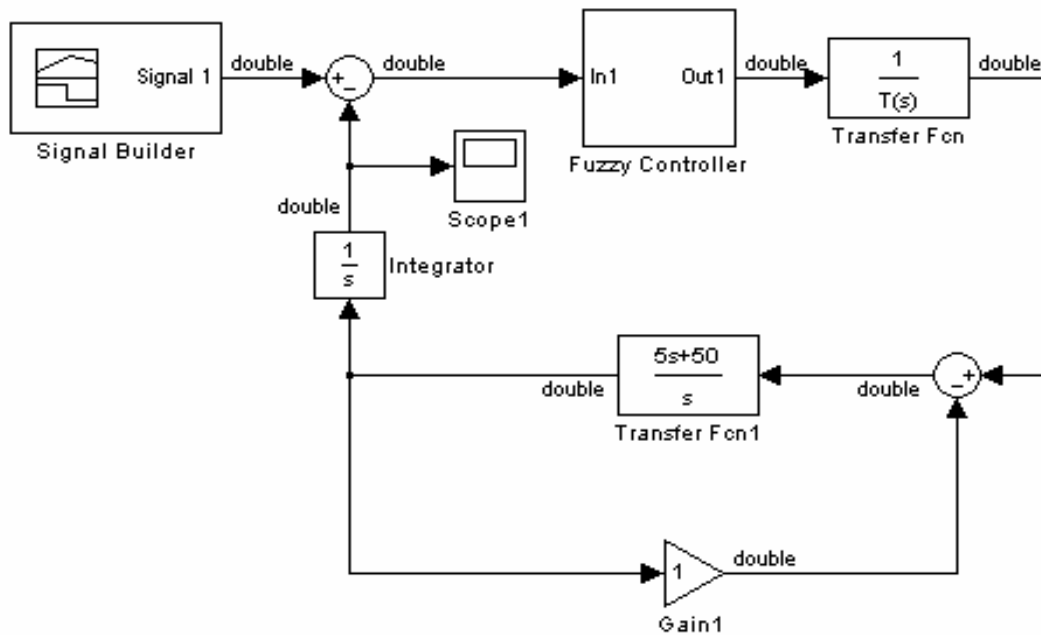

Fig. 11 A fuzzy controller is applied in the tracking loop design.

Table 1 Fuzzy controller cross reference rules.

$E/\Delta E$	NB	NM	NS	ZE	PS	PM	PB
NB	NB	NB	NM	NM	NS	NS	ZE
NM	NB	NM	NM	NS	NS	ZE	PS
NS	NM	NM	NS	NS	ZE	PS	PS
ZE	NM	NS	NS	ZE	PS	PS	PM
PS	NS	NS	ZE	PS	PS	PM	PM
PM	NS	ZE	PS	PS	PM	PM	PB
PB	ZE	PS	PS	PM	PM	PB	PB

Table 2 The relationship functions of E .

Item	Type	Parameter
Negative Big (NB)	Trapmf	[-1 -1 -0.75 -0.3]
Negative Medium (NM)	Trimf	[-0.75 -0.3 -0.15]
Negative Small (NS)	Trimf	[-0.15 -0.1 0]
Zero (ZE)	Trimf	[-0.05 0 0.05]
Positive Big(PB)	Trimf	[0 0.1 0.15]
Positive Medium (PM)	Trimf	[0.15 0.3 0.75]
Positive Small(PS)	Trapmf	[0.3 0.75 1 1]

Table 3 The relationship functions of ΔE .

Item	Type	Parameter
Negative Big (NB)	Trapmf	[-4.5 -4.5 -3.375 -1.35]
Negative Medium (NM)	Trimf	[-3.375 -1.35 -0.72]
Negative Small (NS)	Trimf	[-1 -0.5 0]
Zero (ZE)	Trimf	[-0.25 0 0.25]
Positive Big(PB)	Trimf	[0 0.5 1]
Positive Medium (PM)	Trimf	[0.72 1.35 3.375]
Positive Small(PS)	Trapmf	[1.35 3.375 4.54.5]

Table 4 The relationship functions of U .

Item	Type	Parameter
Negative Big (NB)	Trapmf	[-12 -12 -9.6 -8.4]
Negative Medium (NM)	Trimf	[-9.4 -8.6 -7.2]
Negative Small (NS)	Trimf	[-8.4 -4.8 0]
Zero (ZE)	Trimf	[-4.8 0 4.8]
Positive Big(PB)	Trimf	[0 4.8 8.4]
Positive Medium (PM)	Trimf	[7.2 8.4 9.6]
Positive Small(PS)	Trapmf	[8.4 9.6 12.12]

4.2 Antenna performance analyses

Then the antenna performance design by fuzzy controller is analyzed by simulation with model in Fig. 11. Figs. 12-13 show the antenna tracking responses for T to be as 1 and 1.5, respectively. It can be seen that the results are better than those obtained by the traditional ones for the cases of T to be as 1 and 1.5

5 Integration of PI & Fuzzy Control

If one makes the integration of the traditional and fuzzy controllers by taking the weighting factors respectively as w_1 and w_2 as shown in Fig. 14, then the performances of the antenna tracking responses with $w_1=0.95$ and $w_2=0.05$ are in Figs. 15-17 (respectively for $T=0.1, 1$ and 1.5). If one makes another choice ($w_1=0.9$ and $w_2=0.1$), then the results are in Figs. 18-20. It can be seen that the results obtained with $w_1=0.9$ and $w_2=0.1$ are much better than the other case as well as those obtained either by the traditional controller or the fuzzy controller.

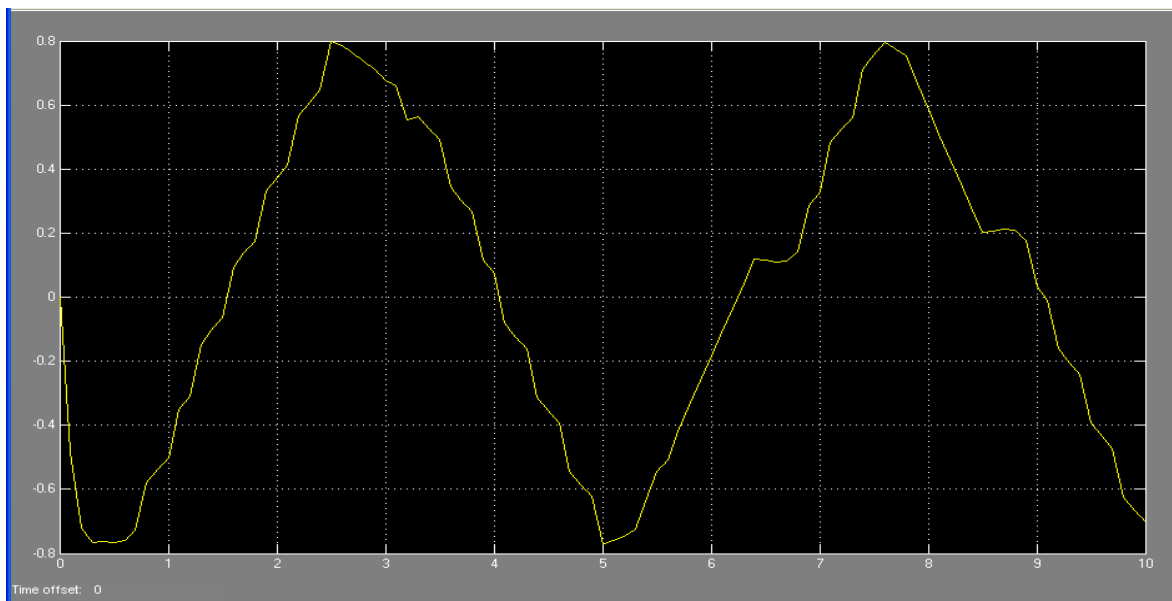

Fig. 12 Gimbal angle output obtained by fuzzy controller with $T=1$.

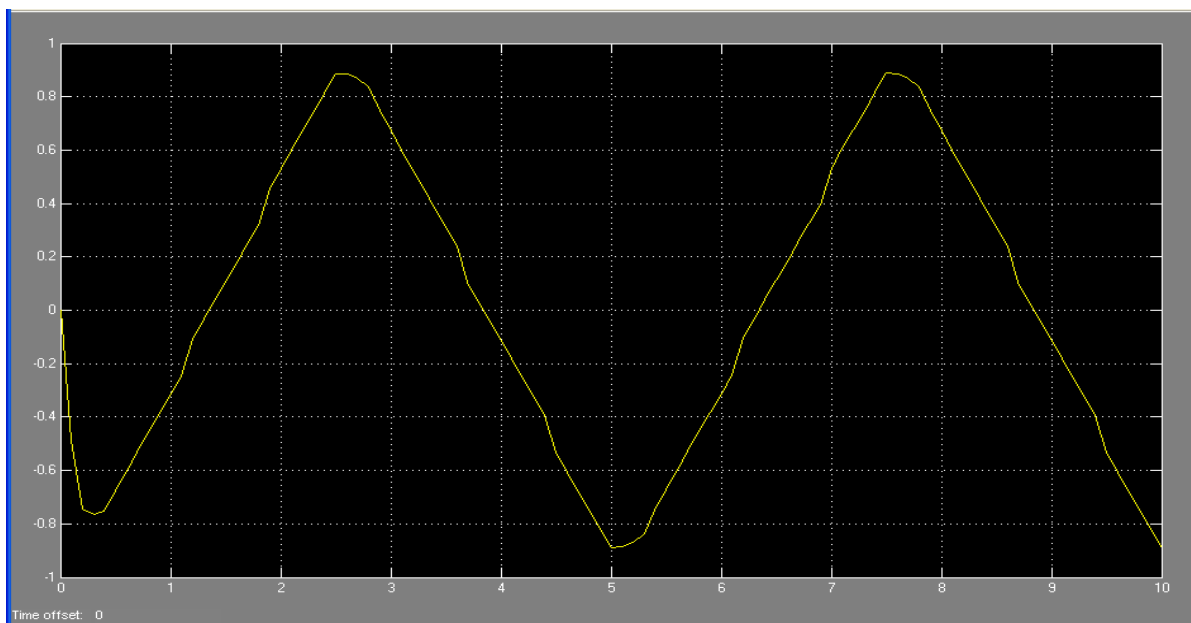

Fig. 13 Gimbal angle output obtained by fuzzy controller with $T=1.5$.

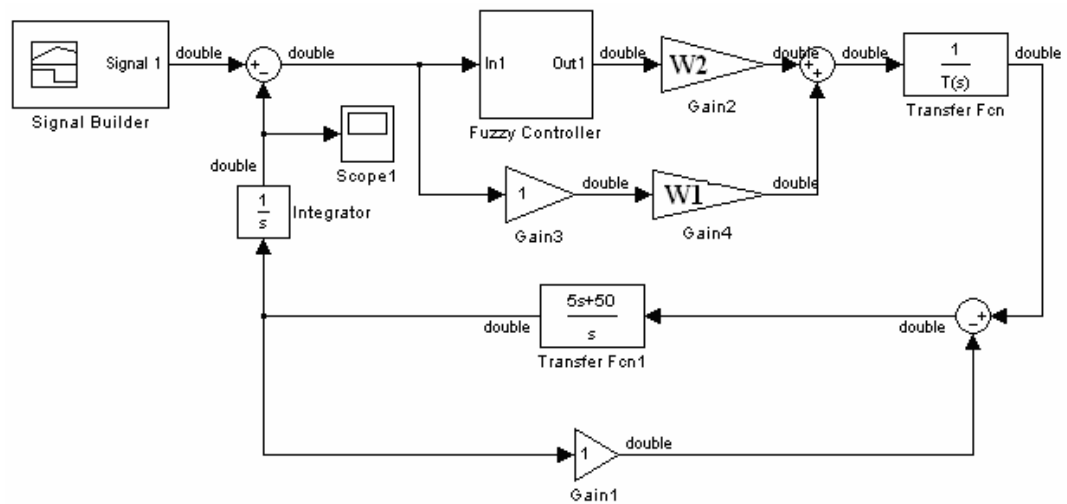

Fig. 14 Integration of traditional and fuzzy controllers by taking the weighting factors respectively as w_1 and w_2 .

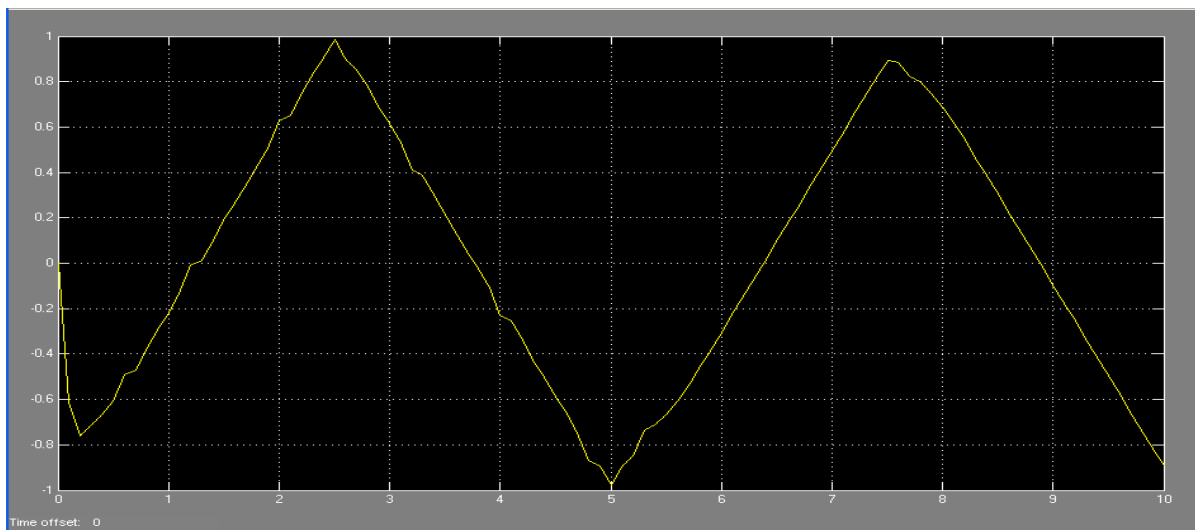

Fig. 15 Gimbal angle output for the integration method with $w_1=0.95$ and $w_2=0.05$ and $T=0.1$.

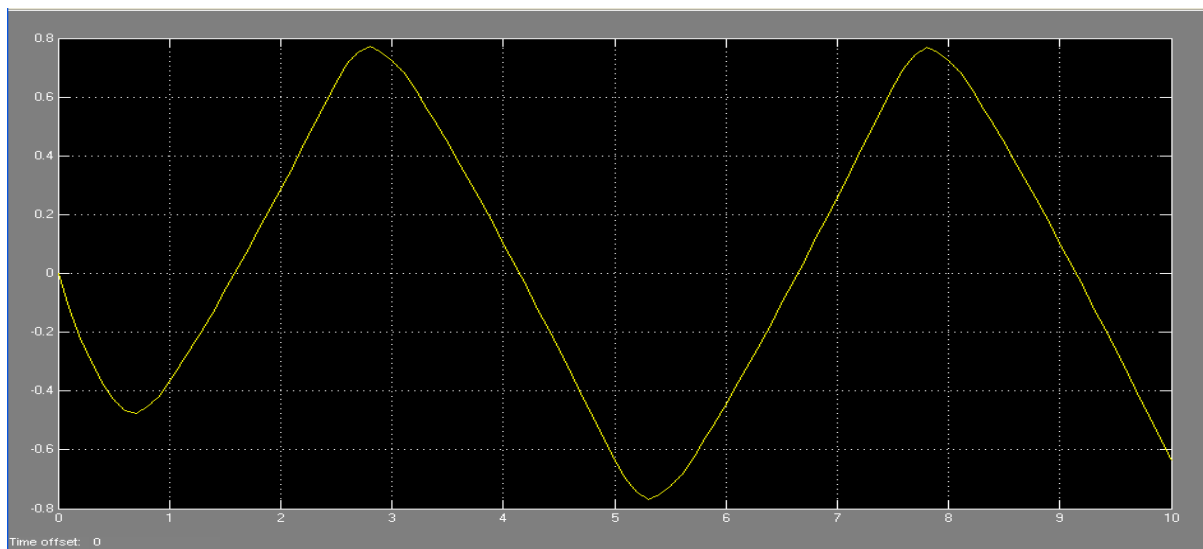

Fig. 16 Gimbal angle output for the integration method with $w_1=0.95$ and $w_2=0.05$ and $T=1$.

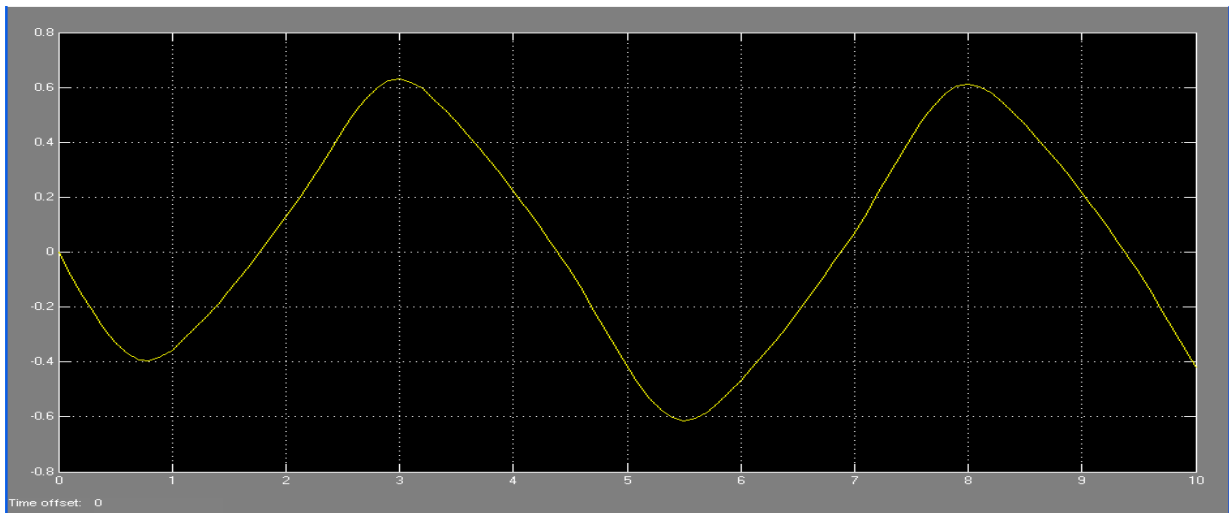

Fig. 17 Gimbal angle output for the integration method with $w_1=0.95$ and $w_2=0.05$ and $T=1.5$.

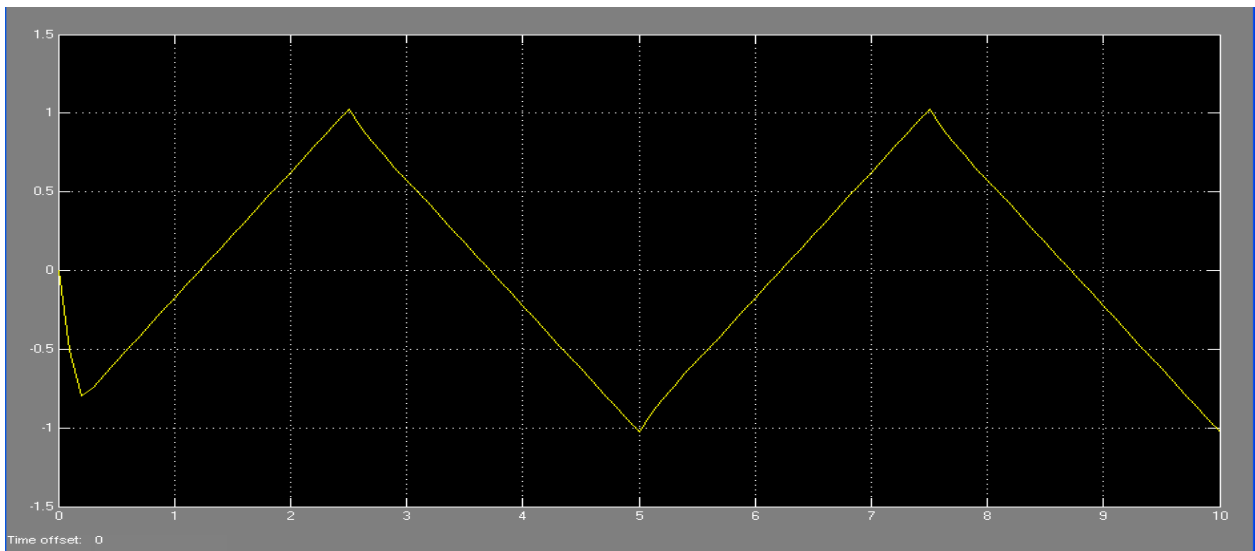

Fig. 18 Gimbal angle output for the integration method with $w_1=0.9$ and $w_2=0.1$ and $T=0.1$.

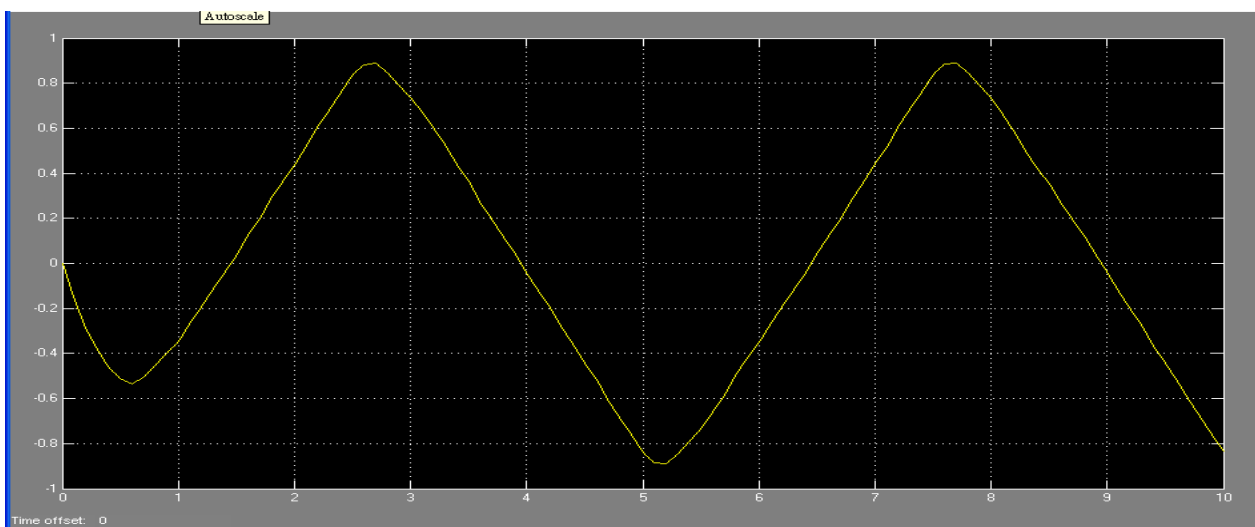

Fig. 19 Gimbal angle output for the integration method with $w_1=0.9$ and $w_2=0.1$ and $T=1$.

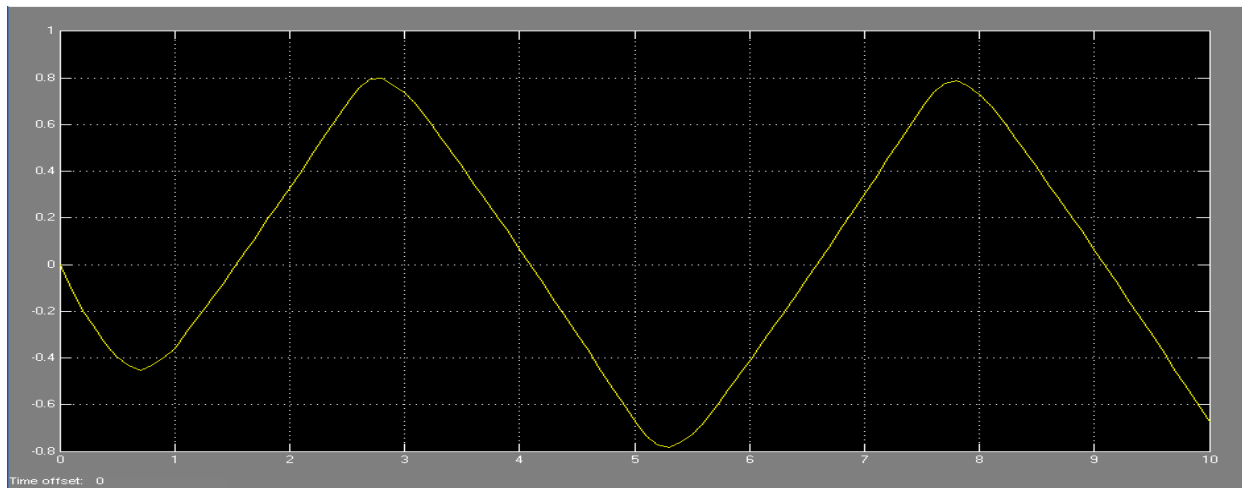

Fig. 20 Gimbal angle output obtained by the integration method with $w_1=0.9$ and $w_2=0.1$ and $T=1.5$.

5 Conclusion

This research applied both the traditional design and the fuzzy control methods for mobile satellite tracking antenna system design and performance analyses. The antenna tracking and the stabilization loops were designed first, and then the tracking gain parameter variation effect in the tracking loop was taken into consideration. It can be seen that the performances would be degraded with the lower tracking gains. On the other hand, the fuzzy controller method was also applied for design. It can be seen that the system performance obtained by the fuzzy controller was better for lower tracking gain. Thus this research proposes to integrate both the traditional and fuzzy controllers by taking appropriate weighting factors. The results show that the performances are better, and the tracking gain parameter variation effect can be reduced.

Acknowledgment

This work was supported by the grant of National Science Council of the Republic of China with the project number NSC 95-2623-7-216-001-D.

References:

- [1] A. C. Densmore and V. Jamnejad, Two WKa-band Mechanically Steered and Mobile Antennas for the NASA ACTS Mobile Terminal, *Proc. Advanced Communications Technology Satellite Program Conference*, NASA, Wash., D.C., 1992.
- [2] A. C. Densmore and V. Jamnejad, A Satellite-Tracking Ku- and Ka-band Mobile Vehicle Antenna System, *IEEE Trans. on Vehicular Technology*, Vol. 42, No 4, 1993, pp. 502-513.
- [3] V. Jamnejad and A. C. Densmore, A Dual Frequency WKa-band Small Reflector Antenna for Use in Mobile Experiments with the NASA Advanced Satellite Communications Technology, *IEEE APSIURSI Joint Intern. Sym. URSI Digest*, 1992, p.1540.
- [4] P. Estabrook and W. Rafferty, Mobile Satellite Vehicle Antennas: Noise Temperature and Receiver G/T," *Proc. IEEE Vehicular Technol. Conf*, Vol.2, San Francisco, CA, USA, 1989, pp. 757-762
- [5] H. C. Tseng and D. W. Teo, Ship Mounted Satellite Tracking Antenna with Fuzzy Logic Control, *IEEE Trans. on Aerospace and Electronic Systems*, Vol. 34, No. 2, 1998, pp. 639-645.
- [6] Y. Zhang, G. E. Hearn, and P. A. Sen, A Neural Network Approach to Ship Track-keeping Control, *IEEE J. of Oceanic Engineering*, Vol. 21, No. 4, 1996, pp. 513-527.
- [7] H. Zhang and D. Liu, *Fuzzy Modeling & Fuzzy Control*, New York: Springer-Verlag, 2006.
- [8] P. S. Hari, P. R. Kumar, D. T. Rao and K. R. Rajeswari, Fuzzy Modeling for Discrimination and Merit Factor of Radar Signals for Range Resolution, *Proceedings of the 7th WSEAS International Conference on Multimedia Systems & Signal Processing (MUSP'07)*, Hangzhou, China, April 15-17, 2007, pp. 146-151.
- [9] G. Noriega and M. Strefezza, Direct Torque Control of a Permanent Magnet Synchronous Motor with Pulse Width Modulation Using Fuzzy Logic, *WSEAS Transactions on*

Electronics, Issue 11, Vol. 4, November, 2007
pp. 245-252.

- [10] B. Nicu-George, P. Anca, and B. Elvira, Conventional Control and Fuzzy Control Algorithms for Shape Memory Alloy Based Tendons Robotic Structure, *WSEAS Transactions on Systems and Control*, Issue 2, Vol. 3, January 2008, pp. 115-124.
- [11] T. S. Tsay, Automatic Gain Control for Unity Feedback Control Systems with Large Parameter Variations, *WSEAS Transactions on Systems and Control*, Issue 12, Vol.2, December 2007, pp. 537-545.