

# Development of an advanced embedded system for description of electrophysiological phenomena in ornamental plants by biosignals processing

KALOVREKTIS K<sup>1</sup>, GANETSOS TH<sup>2</sup>, SHAMMAS N. Y. A.<sup>3</sup>, TAYLOR I.<sup>3</sup>, LYKAS CH<sup>4</sup>,  
ANDONOPOULOS I<sup>2</sup> and LEKAKIS I<sup>5</sup>

<sup>1</sup>University of Piraeus, Informatics Department, Piraeus, Greece

<sup>2</sup>Electronics Department, T.E.I. of Lamia, Lamia, Greece

<sup>3</sup>Staffordshire University, Faculty of Computing, Engineering & Technology, UK

<sup>4</sup>University of Thessaly, Department of Agriculture, Greece

<sup>5</sup>Mechanical Department, TEI of Piraeus, Greece

(email contact: kkalovr@uth.gr)

*Abstract:* - Extracellular electrical signals that are produced from plants have different patterns depending on factors that may cause stress such as water deficiency, nutrient shortages, high salinity level in the root environment etc. In practice, growers and greenhouse control systems acts against the stress factor when visible symptoms are observed, or when the measured values of parameters related to the stress are outside certain limits during a pre-defined period. However, the decrease in plant growth has already begun during this period with consequences for production. The objective of this work is the development of an advanced embedded wireless sensor to detect electrophysiological phenomena in order to investigate the correlation of biosignal patterns to salinity stress in ornamental plants. This embedded system could be used to improve the efficiency of irrigation control systems especially in soilless cultures. For this reason an integrated embedded hardware was designed for plant biosignal measurements. In order to avoid white Gaussian noise (WGN caused from 50 Hz power line noise as well as the noise of the electrical devices operating inside the greenhouse), the IEEE 802.15.4 protocol was used for wireless communication to the embedded systems. Electrical potential difference in leaves of single stem Chrysanthemum (*Chrysanthemum moriflorum*) plants grown in soilless culture and irrigated with low and high electrical conductivity (EC) nutrient solution were measured using the embedded wireless system and a traditional wire data acquisition system (DAQ). The measurements are recorded for a period of 4 days, via a data acquisition system and processed using LabVIEW code. The results show that biosignal measurements on plants, obtained with the use of the design wireless embedded system have a negligible error in contrast to wired data acquisition, since these are not affected by RF and other similar signal noise. The experimental measurements showed that there is a significant correlation between the mean voltage value of the measured biosignal ( $\bar{V}$ ) and the EC level of the substrate where the plants were grown.

*Key-Words:* - Biosignal, chrysanthemum, Ag/AgCl, wireless sensor, amplifier, salinity stress, electrical conductivity

## 1 Introduction

Any living cell continuously receives information from the environment and acts by adjusting their physiology. Accordingly environmental changes cause electrical signals that reflect the responses of a plant to the environmental changes [1-3]. Extracellular electrical phenomena in plants can be divided in three types: local electrical potential (LEP), action potential (AP) and variation potential (VP). Transition of VPs from the stimulated site to

other parts of the plant have been reported in a variety of plant species in response to various stimuli, including light, temperature, humidity, osmotic stress, water status, gravistimulation and wounding [4-7]. By measuring VPs, it is possible to acquire information for a stress factor that may affect plants growth and production. Mechanical, physical or chemical external irritants act not only at the place of occurrence, but the excitation can be also transferred along the whole plant [8-10]. This makes feasible the detection and acquisition of biosignals in the leaves and the stems of the plants

which are more accessible for appropriate sensor installation. However biosignals transfer and their magnitude depends on many internal factors, such as temperature, water status and previous excitations of the plant, the intensity of the irritation, etc. Ambient environment noise can also include external events that affect the measured phenomenon [11]. Electromagnetic interference (EMI) is any unwanted signal which interferes with, or modifies, desired signals at a receiver. EMI can originate from natural causes, such as lightning, or from man-made sources, automobiles, or electronic data processing equipment [12-15]. Signal noise can be also added to a wire data acquisition system via electrical wires cables (50Hz) placed into the laboratory or into the greenhouse. For this reason, plant electrical signals were always recorded over short intervals under laboratory conditions [16], where plants were placed in Faraday's cage (FC) in order to eliminate the unwanted noise.

The aim of this work is to design a wireless embedded system that will not be affected by the noises of the ambient environment. The wireless embedded acquisition system will be a component of an advanced completed measurement system which will be used for the detection and the acquisition of the electrical signals of the plants. These electrical signals will be used to explain electrophysiological phenomena related to the EC of the irrigation water. The processes of the acquired electrical signals will be performed by the appropriate LabVIEW code in a computer station.

## 2. Material and methods

The design of the advanced development embedded wireless system for acquisition of biosignals in plants, includes three (3) modules.

1. A signal amplifier
2. An anti-alias filter
3. A microcontroller for data acquisition and wireless transmission of biosignal.

### 2.1 Signal amplifier and anti-alias filter

The aim of the signal amplifier is to amplify the acquired electrical signal. These signals acquired by Ag/AgCl electrodes which have great stability in temperature alterations as well as in polarization and erosion. In addition Ag/AgCl electrodes has high resistance which is compatible to the input impedance of the preamplifier ( $>10^{10} \Omega$ ).

Due to very low current level of plants electrical signal it was necessary to acquire the signal by an amplifier with very high input impedance, very low input current, and high speed performance. For these reason the developed amplifier shown in Fig.1 had very high input impedance and high gain coefficient.

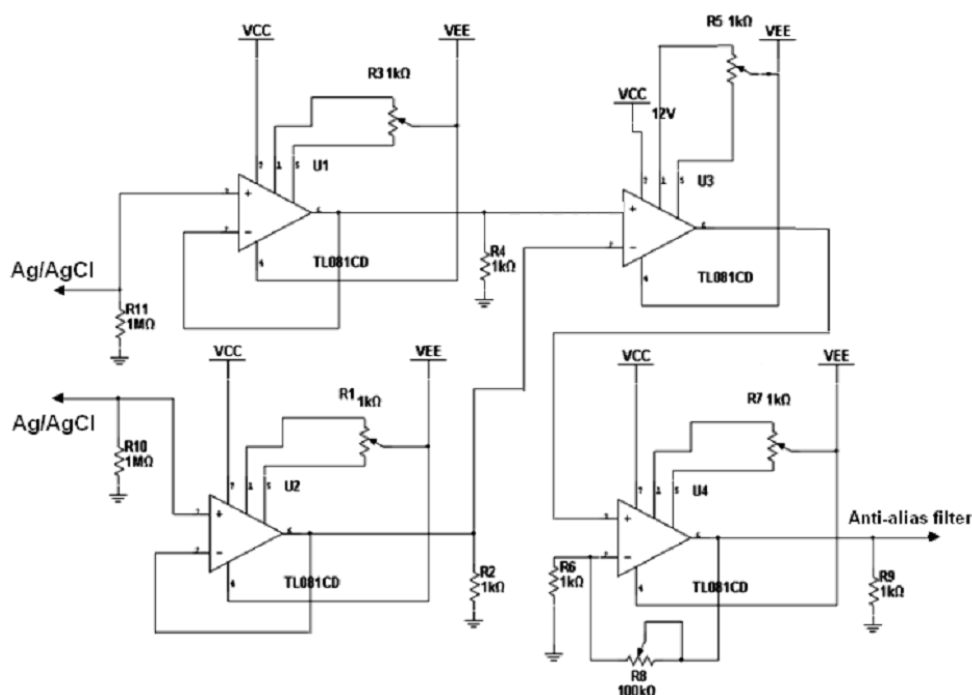

Fig. 1: Interface and amplifier circuit for biosignal acquisition.

The amplifier included two levels. The first level of the high impedance amplifier included two operation amplifiers, one for each electrode (reference and measure) in a voltage follower connection. The specification of this connection allows the adaptation of the high independence of the Ag/AgCl electrode to the input of differential amplifier. The used integrated circuit was the TL081CD.

The second level of the amplifier included the main amplifier of the module. This amplification stage includes a high gain operation amplifier in differential mode connection. The gain of amplification of the designed circuit was 40 dB. The output of the amplifier was connected to an anti-alias 8<sup>th</sup> order Butterworth filter. Butterworth filter was designed to have a flat frequency response. The circuit diagram is shown in Fig.2. The pass band frequency of the designed filter was at 5 kHz due to the sample rate of the analog to digital converter. The rate signal to noise of the designed filter was -72dB.

## 2.2 Data acquisition and wireless transmission hardware

The hardware part of the data acquisition of biosignal from the amplifier module includes two modules. The first module is an 8 bit microcontroller for biosignal data acquisition. The sample rate of the analog to digital convection was at 10 ksamples/s [17]. The second module of this

part included a micro RF modem for wireless biosignal transmission. ZigBEE/IEEE 802.15.4 was the used protocol for the wireless embedded system and was selected for the following reasons:

1. A ZigBee network contains more than 65,000 nodes (active devices). The network may have the shape of a star, a branching tree or a net (mesh). The ZigBee protocol does not require a host/slave configuration, which is necessary for the operation of many similar technologies; provide flexibility in networking topologies such as mesh networking, broadcast mode, and packet rerouting. For this reason, more embedded systems of Ag/AgCl sensor can be added.
2. The low-powered ZigBee, offers a wireless transmission range of 60 meters.
3. ZigBee protocol offers low transmission bandwidth, high frequency transmission 2.4 GHz and low rate errors since they are unaffected from electromagnetic fields.
4. ZigBee provides low-power electricity consumption during data transmission. No extra power source is required for the transmission module.
5. For reliable and secure data transmission in wireless networks, ZigBee offers a security toolbox including access control lists, data freshness timer and 128-bit encryption.

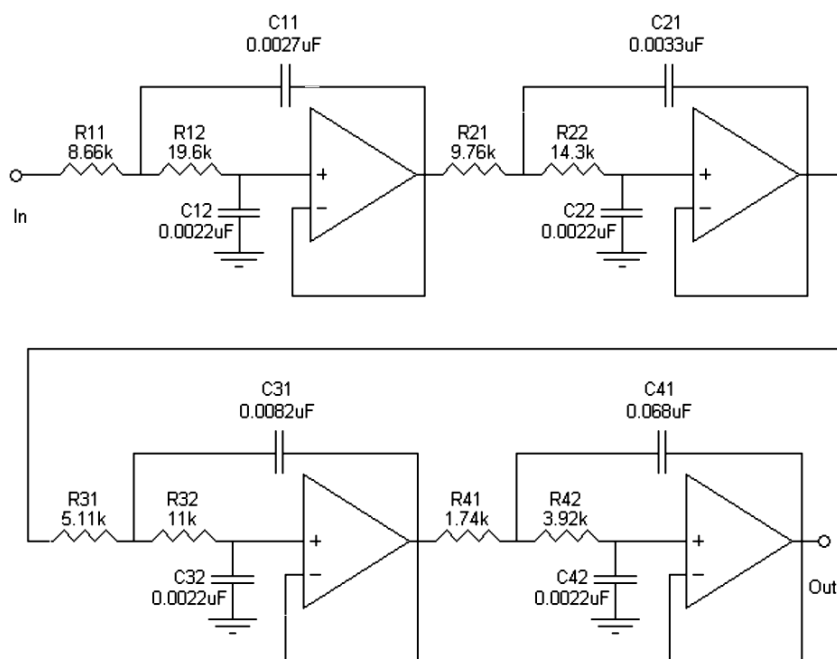

Fig.2: Circuit design of 8<sup>th</sup> order Butterworth filter.

The completed embedded system is shown in block diagram of Fig.3. This was consisted from a) the microcontroller which includes MAC Layer, Network Layer, security, and the application profile, b) the module of amplifier c) the anti-alias filter, d) the interface circuits of electrodes and e) the Ag/AgCl measure electrodes. The completed measurement system used for the wireless biosignals acquisition included:

1. One Reduced Function Device (RFD) for each pair of Ag/AgCl electrodes, to acquire and transmit plants biosignals.

2. One Full Function Device (FFD) acting as Coordinator to collect data from RFD module. Each FFD and RFD unit included a programmable microcontroller with stack architecture, which is made up of blocks called layers: the Medium Access Control (MAC) layer, the Network Layer, the secure layer and the Application layer.

3. The LabVIEW interface for screening and recording the acquired biosignals.

The block diagram of the total measurement system is shown in Fig.4.

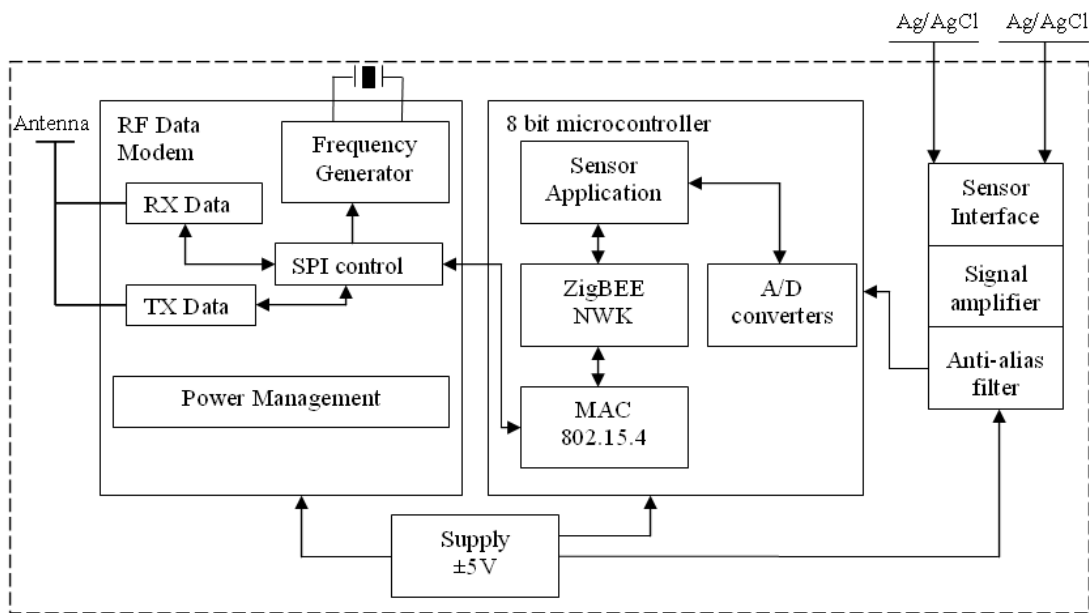

Fig.3: Block diagram of the embedded system.

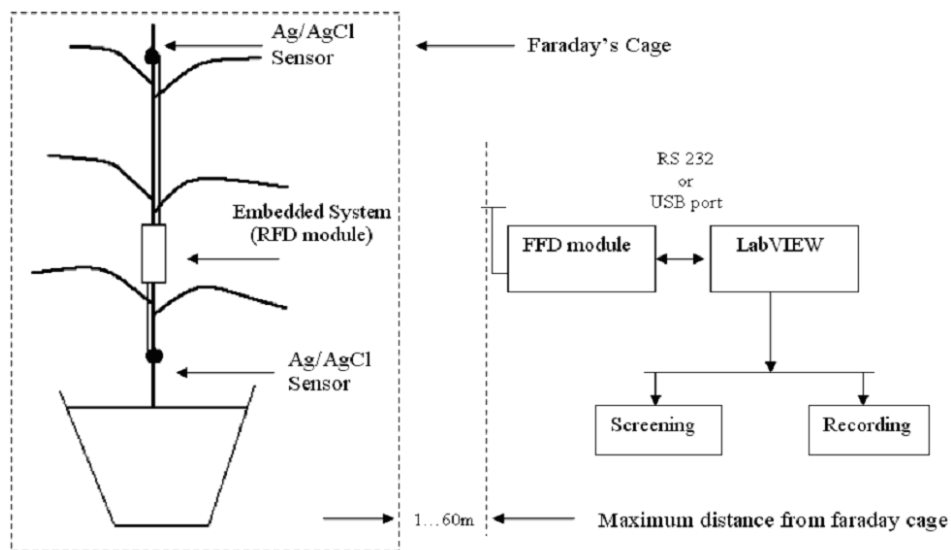

Fig.4: The completed measurement system for biosignals acquisition.

Software is running in the memory of the microcontroller supported from IEEE 802.15.4 stack. In the present design, for the handling of FFD and RFD units the PIC18LF4620 microcontroller was selected, because of:

1. Low power consumption
2. Low input voltage for operation (nanowatt Technology)
3. Support of synchronous and asynchronous communication gates with sensors and integrated ZigBee radio transceivers.

The transmitter and receiver circuit of ZigBee signals were included on the main board. The CC2420, (2.4GHz) integrated RF modem was used. The RF modem chosen due to their special functions on data handling packets and the link quality indication. These functions reduce the operational load of the microcontroller, leading to the selection of a model with smaller size and cost. The communication between microcontroller and RF modem was performed through a Serial Peripheral Interface (SPI). The Printed Circuit Board (PCB), which was designed and developed for the wireless system operation is shown in Fig.5. The main board

included a sub-board which was consisted from the connectors of Ag/AgCl electrodes and the amplifier module (Fig.6). The design of the wireless module allows the connection of a maximum number of four pairs of Ag/AgCl electrodes. The maximum number of sensors (N) can be connected to the system, depends on the memory capacity of the data transmitting hardware system (BS), the time response of measurements ( $T_r$ ) and the sample period ( $T_d$ ). This number can be estimated from the equation (1).

$$N = \frac{BS}{a} * \frac{T_r}{T_d} \quad (1)$$

Where  $a$  is the minimum memory capacity of data transmitting hardware system (256 KB). The maximum number of Ag/AgCl sensors can be in connection to the system estimated from equation (1) for different types of Microchip PIC microcontroller. The connection of the coordinator unit (FFD) of the wireless network with the main computer was performed via a serial RS232 or a USB port. Control and measurement information was grouped into ASCII strings.

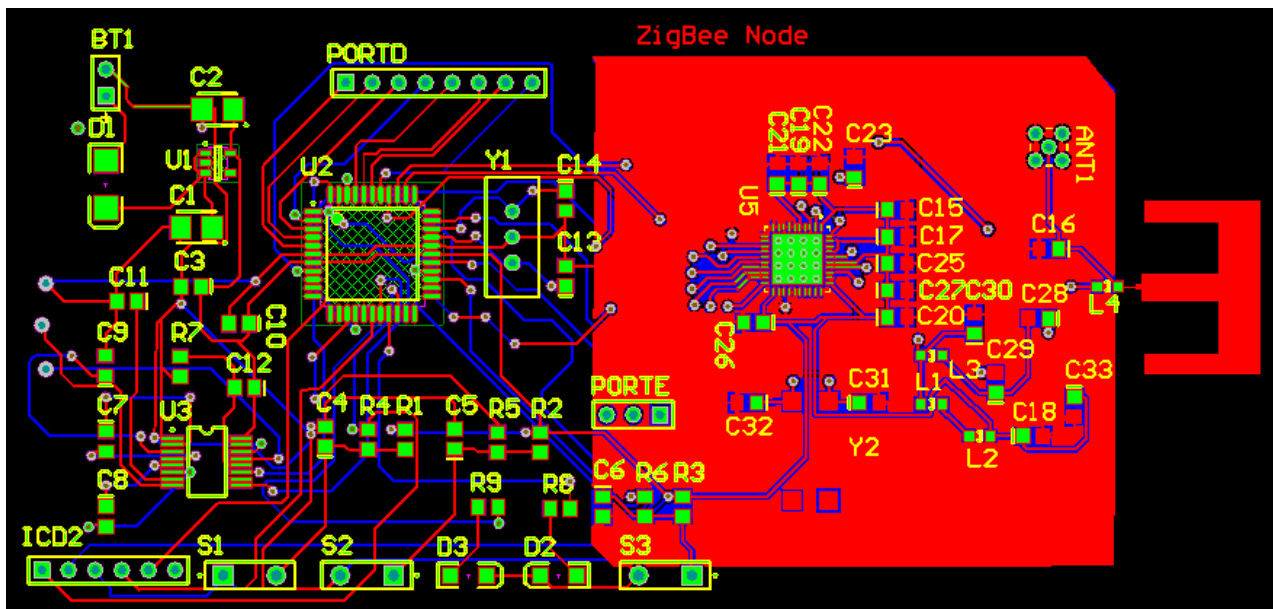

Fig.5: Printed circuit board of the embedded system.

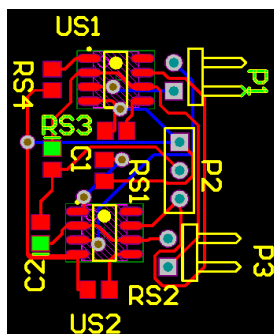

Fig.6: Printed circuit board for pair Ag/AgCl electrode where: P1 is the connection port to embedded system, P2 is the power supply of circuits and P3 is the connection port for Ag/AgCl electrodes.

### 2.3 Use of the designed embedded system to detect electrophysiological phenomena via biosignal acquisition

The designed embedded system was used in the following three experiments in order to detect electrophysiological phenomena in plants:

1. The first experiment concerned the test of the designed embedded system against a traditional wire data acquisition system for biosignal acquisition. The experiment performed in the laboratory of Floriculture in the Department of Agriculture Crop Production and Rural Environment of University of Thessaly, in Greece. During the experiment, electrical potential was measured in leaves of chrysanthemum plants (*Chrysanthemum moriflorum*) using Ag/AgCl electrodes which are placed in soil, as well as in plants stems and leaves. The plant was placed inside a Faraday's cage (FC). The  $\bar{V}$  of the electrical signals were recorded in a data logger placed: i) inside the FC, ii) at a distance of 15 m away from FC, connected with interface circuit via wire and iii) at a distance of 4 m away from FC using a wireless embedded system for data transfer. The rate sample of measurements was 10 ksamples/s [17].
2. The second experiment concerned affect environment noise on the design embedded system. For electromagnetic interference (EMI) testing an EMI-RF generator device in distance of 30 cm away from FC transmit in time duration of 40 ms, two power

transmission A and B ( $p=100$  mW) for each testing frequencies: 0.5, 1.3, 2.3 and 3.3 MHz controlled by labVIEW. The electrical potential in plants was measured and recorded in a data logger placed: i) inside the FC, ii) at a distance of 15 m away from FC, connected with interface circuit via a coaxial wire and iii) at a distance of 4 m away from FC, and using a wireless embedded system for data transfer.

3. The third experiment concerned the use of the embedded system to detect electrophysiological phenomena in plants. For this reason plants were subjected to salinity stress. The experiments of the application were carried out in an experimental unheated greenhouse, N-S oriented, located at the University of Thessaly near Volos, (Latitude  $39^{\circ} 44'$ , longitude  $22^{\circ} 79'$ , altitude 85 m) on the coastal area of Eastern Greece. For this experiment two single stem chrysanthemum plants (*Chrysanthemum moriflorum*) grown in pots which were filled with peat and perlite mixture (2:1) were used. Plants had the same height and the same number of leaves and placed in greenhouse several weeks before the beginning of the measurements. During the experiment period plants remain under the same climate conditions (air temperature, air humidity and incoming light intensity). The EC of tap water used for the irrigation of the plants before the beginning of the measurements was  $0.7$  dS  $m^{-1}$  whereas the EC of drained water after the irrigation varying from  $1.0$  to  $1.1$  dS  $m^{-1}$ . During the experiment period one of the plants irrigated one day before the beginning of the measurements with high salinity water which had an EC value of  $18$  dS  $m^{-1}$ . After that both treated (TP) and control plant (CP) irrigated only with tap water. Irrigation performed every day simultaneously for both plants and the water drained from each pot was collected. A reference Ag/AgCl electrode from the RFD embedded system was placed on the main shoot of each plant, 5 cm upper to substrate whereas another Ag/AgCl electrode was placed on plants leaf 15 cm upper to reference electrode. The substrate of both plants was connected to the ground (Fig.7).

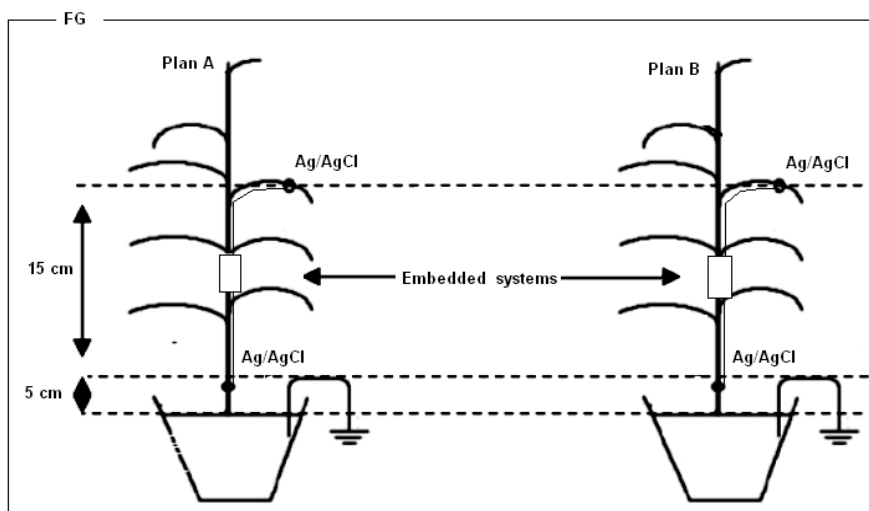

Fig.7: The experimental arrangement for the measurement of the plant signal.

The  $\bar{V}$  of voltage difference between the reference and measure electrodes was measured and recorded every 1 s for a period of 60 min from 10:00 to 11:00 during 4 continually days. During the same period the greenhouse air temperature, air humidity and incoming light intensity were recorded. Pots were irrigated once a day at 11:30. The drained water from each pot was collected and their EC was measured.

### 3. Results and discussion

#### 3.1 Wireless vs. wired data acquisition

The biosignals acquired by data logger placed inside the FC and via wireless transmission from designed embedded system outside the FC had the same evolution (Fig.8) and the same amplitude. The correlation of these two signals is shown in Fig.9. The rate sample of both measurements was 10 ksamples/s [17].

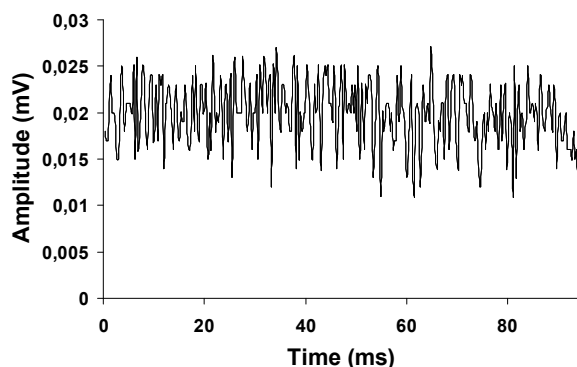

Fig.8: Biosignal evolution acquired by data logger inside the FC and via wireless transmission outside the FC.

This linear correlation indicates that biosignal acquired via wireless transmission was not affected by the noise of the ambient environment due to the 128-bit encryption data of ZigBee [18]. This means that biosignal of the plant can be acquired outside of the FC without distortion by using the designed embedded system. In addition spectrum analysis of these biosignals didn't reveal any differences among them.

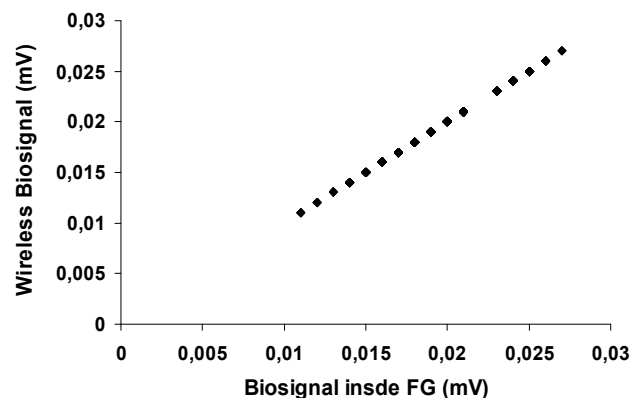

Fig.9: Correlation of biosignal (mV) inside the FC to the biosignal that transmitted by wireless mode to data logger ( $R^2=1$ ).

In contrast the biosignal acquired via wire transmission outside the FC had different amplitude and evolution compared to biosignals acquired by data logger placed inside the FC and via wireless transmission from designed embedded system outside the FC (Fig.10). This can be attributed to i) the length of the wire required to cover the distance from the Ag/AgCl electrodes to data logger and ii) the signal noise of the ambient environment. The

amplitude attenuation of wire signal transmission was -5dB due to the resistance of 15m wire and the connections [19]. Attenuation distortion occurs also when some frequencies are attenuated more than other frequencies due to the wire [20]. Accordingly there is not any correlation ( $R^2=0.0063$ ) between biosignal acquired inside the FC and that acquired by wire mode.

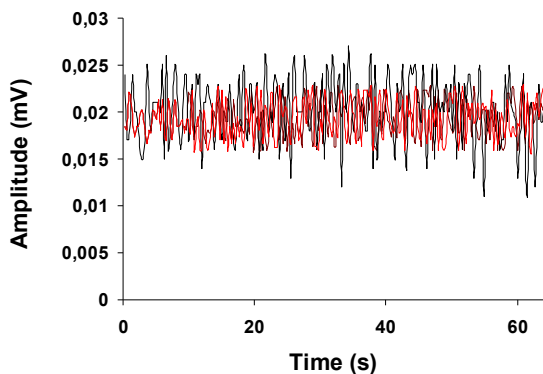

Fig.10: Biosignals (mV) acquired inside the FC (-), via wire (-).

The above mentioned results revealed that the signal acquired via wire affected strongly by the phenomenon of attenuated frequencies [20] and the white noise of the ambient environment. In addition spectrum analysis revealed different harmonics amplitude in comparison to the biosignals acquired inside the FC (Fig.11).

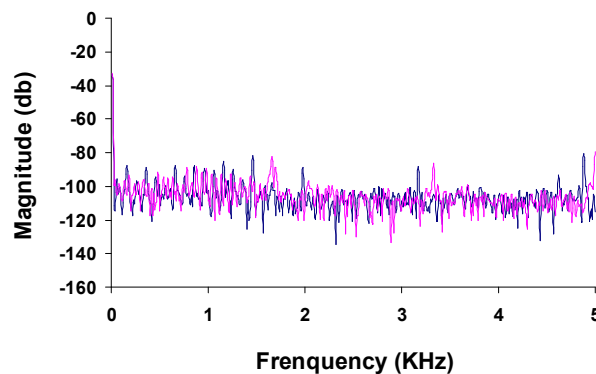

Fig.11: Spectrum analysis of biosignals acquired via wired (-) and wireless (-) transmission.

### 3.2 The effect of signal noise on the performance of wireless embedded system

Due to the affect of EMI testing the acquired biosignal via wire transmission showed distortions (Fig.12). Wireless transmission did not affected by the EMI testing. The Fig.12 shows the distortion of transmitted waves on EMI testing. Outside the duration of transmission the difference of the acquired signals was researched in session 3.1. The magnitude of distortion depended from the wave length of transmitted wave. Te EMI-RF transmission in band from 1000 to 2500 Hz affected strongly the acquired biosignal (Fig.13).

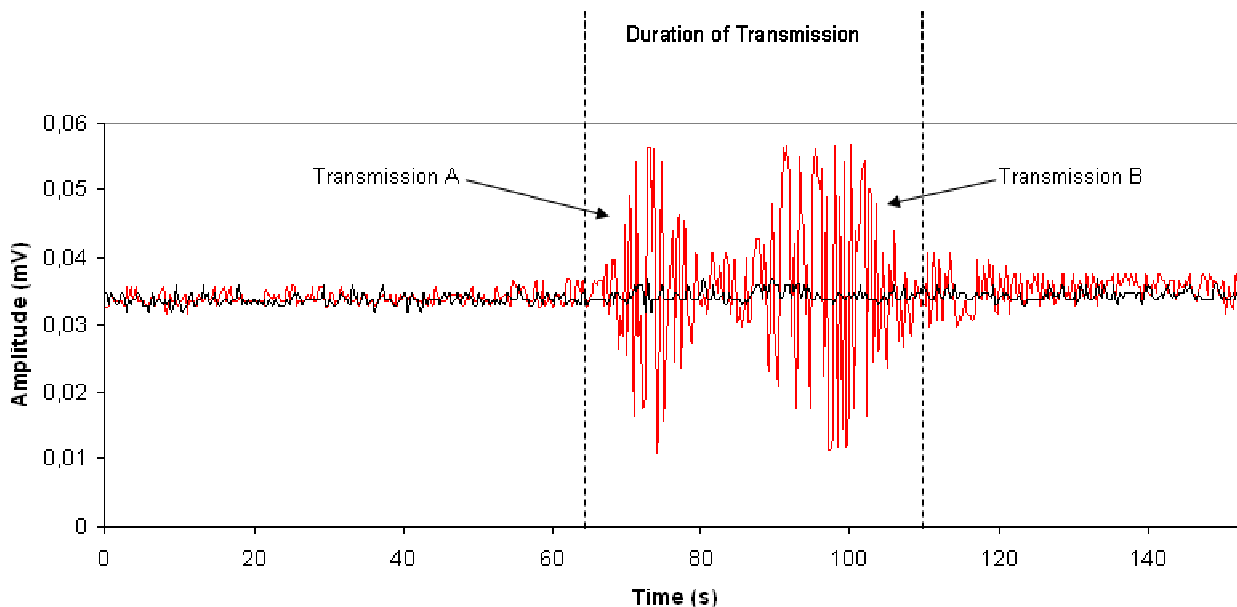

Fig.12: The effect of EMI testing in biosignal via wired (-) and wireless (-) transmission.



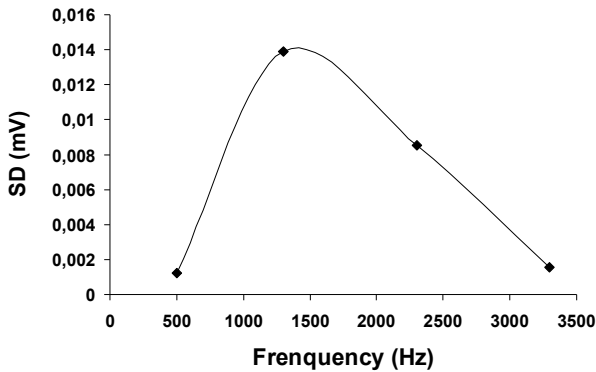

Fig.13: Standard deviation of signals by effect of EMI testing.

### 3.3 Electrophysiological phenomena detected with the use of the designed embedded system.

The climate conditions in the greenhouse where the plants remained during the measurements period are presented in Table1.

Air temperature and humidity were stable during the day but had a significant alteration from day to day. In contrast light energy was almost stable during the three last days of the measurements period. The EC evolution of the drained water collected daily, after the irrigation from TP and CP plants is presented in Fig.14. As it was expected EC value of water drained from CP remain stable during the measurements period having values varied from 1.0 to 1.1 dS m<sup>-1</sup> whereas the EC of water drained from TP decreased continually and reached 1.1dS m<sup>-1</sup> during

Table 1: Measured values of air temperature, air humidity and light energy.

the 4<sup>th</sup> day after continually irrigation with tap water.

The evolution of mean value of signal ( $\bar{V}$ , mV) from CP and TP is similar to the EC evolution of the drained water collected from pots of CP and TP as it shown in Fig.15. The  $\bar{V}$  measured on CP ( $\bar{V}_{CP}$ ) remain almost stable during the measurements period having values varied from 0.1 to 0.13 mV whereas the  $\bar{V}$  measured on TP ( $\bar{V}_{TP}$ ) was very high (0.24 mV) during the 1<sup>st</sup> day, when the EC of the substrate where the plant grown had the higher value (23.3 dS m<sup>-1</sup>), and decreased continually until the 4<sup>th</sup> day when reached 0.09 mV.

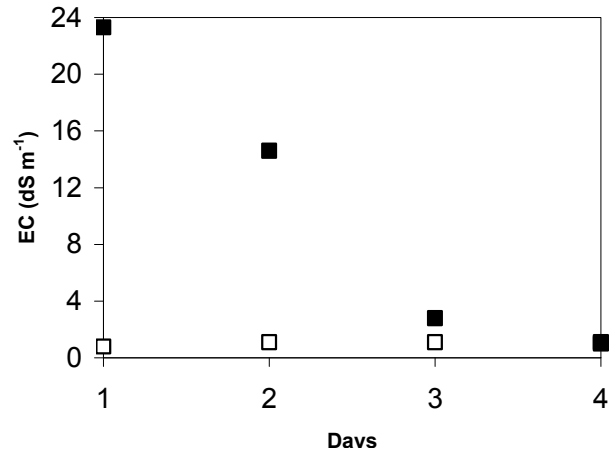

Fig.14: EC (dS m<sup>-1</sup>) evolution of drained water becoming from CP (□) and TP (■) during the measurements period.

Day of the experiment	Mean daily air temperature ( $\bar{T}$ , °C)	SD	Mean daily air humidity (RH %)	SD	Sum of daily light energy ( $\text{MJ m}^{-2}$ )
1 <sup>st</sup>	16.8	0.009	23.4	0.024	22.4
2 <sup>nd</sup>	14.5	0.24	26.9	2.5	9.7
3 <sup>rd</sup>	18.9	0.18	29.4	0.89	10.7
4 <sup>th</sup>	21.0	0.15	30.7	1.08	11.3

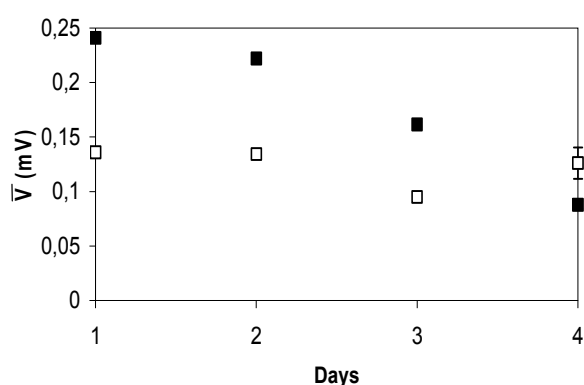

Fig.15: Evolution of mean value of signal  $\bar{V}$  (mV) from CP ( $\square$ ) and TP ( $\blacksquare$ ) during the measurements period.

In contrast the bandwidth of the signal recorded from CP was greater than the bandwidth of the signal recorded from TP.

The evolutions of  $\bar{V}$  (mV) from CP and TP during the 4<sup>th</sup> day that the electrical signals vary at similar levels are shown in Fig.16. During that day the EC of the water drained from CP and TP was 1.0 and 1.1 dS  $\text{m}^{-1}$  respectively. These alterations must be attributed to the climate parameters [21].

A significant correlation between  $\bar{V}$  and air humidity for both CP ( $R^2=0.97$ ) and TP ( $R^2=0.8$ ) was found. However these alterations did not overcome the 0.05 mV whereas the alteration becoming from the EC increment was greater than 0.1 mV.

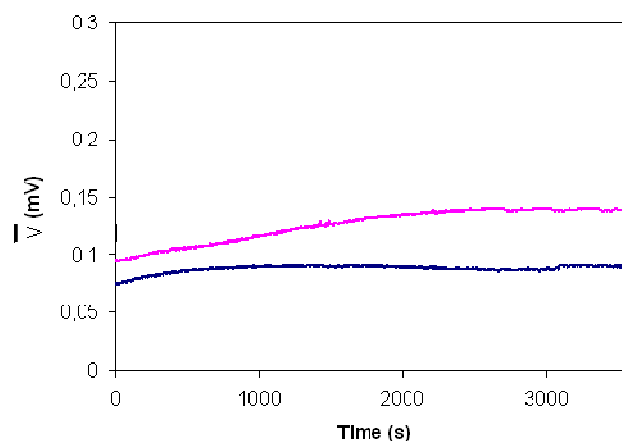

Fig.16: Evolution of mean value of signal  $\bar{V}$  (mV) from CP (—) and TP (—) during the 4<sup>th</sup> day.

## 4. Conclusions

From the above results, we concluded that:

- 1) The design wireless embedded system can be used to acquire biosignals of plants in a more effective way than via wire transmission, since the signal is not affected by the noise of external RF source and that of a typical greenhouse environment, or in a laboratory.
- 2) By the use of the traditional wire system the amplitude of biosignal was affected by about 50% during their acquisition at a distance of 15 m since harmonics distortions caused from the ambient environment resulted to peak voltages signals errors.
- 3) The embedded system can detect electrophysiological changes in the plants, caused by environmental parameters such as the increase of salinity in the substrate

where the plants are rooted, since a significant correlation between  $\bar{V}$  measured in the leaves of the plants and EC measured in nutrient solution drained from the substrate was found.

#### References:

- [1] Mooney, H. A. and Winner, W. E. 1991. Responses of Plants to Multiple Stresses. Eds. *H A Mooney, W E Winner and E J Pell. Pp 129–142. Academic Press, San Diego, California, USA.*
- [2] Reynolds, H. L. and D'Antonio, C. 1996. The ecological significance of plasticity in root weight ratio in response to nitrogen: Opinion. *Plant Soil* 185: 75–97.
- [3] Martynenko, A. I. 2000. Electrophysiological investigation of frost resistance in plants: 3. critical points detected on the freezing of winter wheat. *Russian Journal of Plant Physiology*, 47(6): 734–739.
- [4] Hartman, E. 1975. Influence of light on the bioelectric potential of the bean (*Phaseolus vulgaris*) hypocotyl hook. *Physiol. Plant.* 33: 266 - 275.
- [5] Stankovil, B., Davies, E. 1997. Intercellular communication in plants: electrical stimulation of proteinase inhibitor gene expression in tomato. *Planta* 202: 402 - 406.
- [6] Imagawa, K., Toko, K., Ezaki, S., Hayashi, K., Yamafuji, K. 1991. Electrical potentials during gravitropism in bean epicotyls. *Plant Physiol* 97: 193 -196.
- [7] Ishikawa, H., Abou, S., Ohta, E., Sakata, M. 1983. Effects of periodic and transient osmotic stress on electric potentials in bean roots. *Plant Cell Physiol* 24: 1129 -1135.
- [8] O.S. Ksenzhek, A.G. Volkov, *Plant Energetics, Academic, San Diego*, 1998.
- [9] A.G. Volkov, R.A. Haack, *Bioelectrochem. Bioenerg.* 35 (1995).
- [10] A.G. Volkov, R.A. Haack, *Russ. J. Plant Physiol.* 42 (1995)
- [11] D. Morgan 1994' *A Handbook for EMC Testing and Measurement*', Institution of Engineering and Technology, ISBN: 0863417566.
- [12] R.E. Boyd, J. A. Malack and I. E. Rosenbarker, Technical considerations for establishing narrow-band EMI requirements for data-processing equipment and office machines, *IEEE Trans. Electromag. Compat.* EMC-19 (1977).
- [13] R. Matheson, Instrumentation problems encountered making man-made electromagnetic noise measurements for prediction communication system performance, *IEEE Trans. Electromag. Compat.* EMC-12 (1970).
- [14] C. A. Master, Electromagnetic interference control considerations: solenoid operated control devices, *IEEE Trans. Electromag. Compat.* EMC-11 (1969).
- [15] W. H. Haynes and C. L. Wilderson, Investigation of a dipole model for transient analysis of electromagnetic field coupling into long cables, *IEEE Trans. Electromag. Compat.* EMC-12 (1970).
- [16] Fromm J; Lautner S (2007). Electrical signals and their physiological significance in plants. *Plant, Cell & Environment*, 30: 249–257.
- [17] Tatiana Shvetsova, John Mwesigwa, Alexander G. Volkov, Plant electrophysiology: FCCP induces action potentials and excitation waves in soybean, *Plant Science* 161: 901–909 (2001)
- [18] Ferens, K.; Woo, L.; Kinsner, W.; Performance of ZigBee networks in the presence of broadband electromagnetic noise, *Canadian Conference on Electrical and Computer Engineering*, 2009, CCECE '09.
- [19] D.W. Pryer, P.F. Gale, *Electrical Engineer's Reference Book* (Sixteenth Edition) Ch 31. Cables, Elsevier Ltd, Oxford, UK, 2003
- [20] Rowe, Standord H. II, *Network Technology & Service Integration.* (5th Edition), 2002, Prentice-Hall, Inc., 2002.
- [21] Wang, Z.Y, Leng, O, Huang, L., Zhao, L.L, Xu Z.L, Rui-Feng Hou, R.F, Wang, C. 2009. Monitoring system for electrical signals in plants in the greenhouse and its applications. *Biosystem Engineering.* 103: 1-11, (May 2009).