

Design of a fast, high power magnetic generator for the stimulation of living tissues: A biomedical engineering application of electromagnetism and power electronics.

R. CHARLET DE SAUVAGE(1), Ph. DONDON(2), C. MARTIN(1), J. DONKIN (3),
B. VEYRET (1)

(1) IMS MCM ENSCPB, 16, avenue Pey-berland 33607 PESSAC

(2) ENSEIRB, 1, rue A Schweitzer 33400 TALENCE

(3) Lycée Kaestler, av de l'université 33400 TALENCE

Philippe.Dondon@enseirb.fr, renaud.charlet-de-s@inserm.fr,

Abstract: This paper relates to the design and realisation of a high power (6000 A, 650 V) magnetic generator delivering ultra short (340 μ s) high intensity (2 T) pulses. More than ten years of technical collaboration between two important graduate engineering schools of Bordeaux were necessary to carry out this project. This practical realisation was supported perfectly by the power electronics, electromagnetism and microprocessor courses given at ENSCPB and ENSEIRB graduate engineering schools. In the first place, we explain the educational interests of this realisation. Then, we give a detailed description of the system, including the tests which were used to check the specifications. Finally we conclude on possible uses of our equipment in biomedical research. As an illustration of bio medical applications, our apparatus was used for tests on living tissues (animal, bacteria, etc).

Key words: Magnetic stimulation, Living tissues, Biological tests, Power electronics, Electromagnetism

1. Introduction

1.1 ENSEIRB, a graduate engineering school

The "Ecole Nationale Supérieure d'Electronique, Informatique et Radiocommunications de Bordeaux" (ENSEIRB) is one of the oldest national graduate engineering schools, known as 'Grandes Ecoles' in France. It was founded in 1920. Even though it is an independent structure, ENSEIRB is closely linked to the Bordeaux 1 Science and Technology University.

ENSEIRB has developed with the growth of information and communication technologies. A Computer Science Department was created in 1986 to complement the original Electronics Department. The expansion has proceeded in year 2000, with the development of a new Department of Telecommunications.

1.2 IMS, a research laboratory

The place where this study was carried out is the IMS¹ laboratory, a mixed structure associating the

French CNRS Institute with the Practical School for High Studies (EPHE) and the University of Bordeaux 1. The IMS laboratory has manpower of 304 people. Its MCA (Micro technologies, Sensors and Microwaves) department deals with several - topics, one of which is concerned with bioelectromagnetics. The Bioelectromagnetic team is interested in the study of the biological effects of transcranial magnetic stimulation (TMS). The MCM department is housed in the building of the graduate engineering school of Chemistry and Physics of Bordeaux (ENSCPB). Similar to ENSEIRB, ENSCPB is closely linked to the University of Bordeaux 1.

1.3 The magnetic stimulator project

The Bioelectromagnetic team is the team who developed the prototype of high power magnetic pulse generator. More than ten years were necessary for developing this bench. In addition to the training opportunity this project constituted for the students, the aim was also to design a flexible tool for the stimulation of living tissues for either laboratory or industrial use.

¹ IMS = Integration from Material to Systems.

1.4 Educational Interests

1.4.1 National aspects

During the past 10 years, important changes in student's behaviour have been observed. Teachers are facing a new kind of public with an unfamiliar behaviour they do not know how to manage [29]. Some major evolutions and new difficulties are listed below:

- a global disinterest for theoretical sciences is observed [16], [20], [22]: This phenomenon is confirmed by national [18] and local statistics. There is a global loss of motivation for scientific matters. The total number of French students carrying on studies at a university level is decreasing with an annual rate of 1,3%. And the national rate of students choosing sciences studies is less than 2%. Within the University of Bordeaux, Fundamental sciences represent less than 15% of the students. (cf. table 1).

Number of Students - year 2006-2007	Bordeaux university
Rights, political sciences	7 766
Economic sciences, management, social and economic administration	6 496
Languages	5 608
Literature and Human sciences	14 265
Life sciences	4 310
Fondamental sciences and applications*	9 032
Sport	960
Medicine and odontology	9 392
Pharmacy	1 365
Total all Fields	59 194

Table 1: Distribution of students per field of studies at the university of Bordeaux (INSEE sources)

1.4.2 ENSEIRB particularities

Important changes have been noticed in students' behaviour. Teachers are faced with a new kind of public, with unfamiliar behaviours they do not know how to deal with. Some major evolutions and new difficulties are listed below:

- Most students have a lot of extra scholar activities, such as sport, computers, internet electronic games, and other leisure. These activities are quite interesting from the point of view of

personal development but, concurrently, they generate an excessive dispersion of mental energy and a loss in terms of written culture.

- A higher passivity is noticed during classical courses. Using modern tools during a lecture, such as "power point projections" and/or beginning a lecture distributing paper copies of the course as a basic support, has some adverse effects. Indeed, the students are listening to and looking at lessons as spectators would do in a cinema. Consequently, a break in short-term memorisation processes is observed, ending in a poor knowledge appropriation.

- A reduced attention capacity (in normal human beings the attention period usually lasts for about 45 to 60 min) is also observed. Due to a progressive, faster than before, unhooking of the audience, the efficiency of a traditional 1 hour course with a theoretical content is now poor. All these observations are confirmed by Neuro Linguistic Programming studies [20], among others. The "attention-short sleep-wake up" cycles are related to natural and permanent switching mechanisms between internal and external conscious states in any individual (figure1).

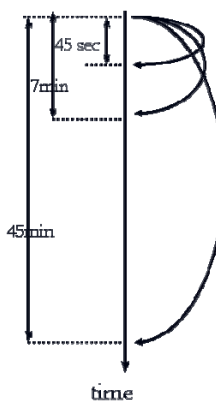

Fig 1 : natural human cycle of attention

In particular, electromagnetism and power teaching in ENSEIRB, is badly perceived by the students [23].

We have still limited the time dedicated to theoretical lessons:

- power electronics (6 hours during the second year of study, + 12 hours optional).
- physics and semi conductors lessons (20 hours during the first year)
- electromagnetism (18 hours during the first year).

Such a concrete and multi thematic project as the magnetic stimulator design was an excellent opportunity for the students to see the necessity of these theoretical fields. During more than 10 years, this project has been used as a teaching support for approximately 20 students, bringing them important motivating practices throughout their training periods. Lastly, the medical purpose of the project was an additional motivation source for our students.

2. Dealing with magnetic stimulation

2.1 Different types of magnetic stimuli

Two types of transcranial magnetic stimulations have developed:

- TMS corresponds to the production of a single magnetic pulse
- rTMS (repetitive transcranial magnetic stimulation) relates to magnetic stimuli being repeated at a continuous rate. Slow and fast rTMS are distinguished, depending on whether the rate is lower (respectively higher) than 1 pulse /s. rTMS can selectively increase or decrease neuronal activity in distinct brain areas, thus giving rise to different types of rTMS applications. It should be noted that this categorization is not related to the stimulation frequency used.

2.2 The classical applications

A first type of applications is the use of rTMS as a research tool in cognitive neurosciences [26] [27]. For instance, TMS is used to interfere with brain function during the course of a mental task (i.e. enumeration of objects). This procedure enables the cerebral localization of the task.

A second type of applications concerns the use of TMS as a diagnostic tool in neurology, for the functional exploration of cerebral or neural functions. The measurement of the response time of a motor nerve is an example of this category. Following a suprathreshold TMS pulse delivered to a particular area of the motor cortex, action potentials generated in the motor cortex are propagated along central and peripheral motor pathways down to the muscle region. A motor reaction can be observed in the target zone (typically a group of hand or leg muscles) allowing the recording of an evoked electromyographic response in the vicinity of the muscles. When

measuring the delay between the TMS pulse and the electromyography response, the conduction velocity of the nerve can be calculated, with applications in different types of neuropathies.

A third category of TMS applications is the use of TMS as a therapeutic tool, particularly in neuropsychiatry. Examples of this category are:

- the possible use of TMS for treating migraine,
- the use of rTMS in clinical assays for the treatment of drug-resistant depression, either fast magnetic stimulation applied to the left prefrontal cortex, or slow magnetic stimulation applied to the right prefrontal cortex,
- attempts to use rTMS in Parkinson symptoms or in the handling of auditory hallucinations in schizophrenia.

2.3 International and commercial context

Several magnetic stimulators are commercially available, mainly designed for being used in hospitals. Main companies are: Magstim, Medtronic, Cadwell, Nexstim, ...

2.4 The technical benefits specific to our system

Some advantages of our device are its flexibility, modularity (pulse duration, waveform, repetition rate...), and its evolving capacity due to an easy micro-controller reprogramming. The apparatus has been designed to achieve an easy maintenance (thanks to the use of low cost electronic -multi sources- components) [21] and to make it suitable for testing living animal tissues.

3. Description of our stimulator

3.1 General principles

The stimulator consists of a high voltage, high power capacitor, discharged in a magnetic coil [9] through a thyristor switching system [1]. The coil and capacitor make a resonant R, L, C circuit, with a damping factor $\alpha = R/2L$. Following the generation of a magnetic pulse, the capacitor (a set of capacitors in parallel), is recharged by a power supply unit connected to the mains. This allows setting amplitude and polarity of the condenser voltage, through a 4-thyristor bridge. A microcontroller (μC) board is used to command the

whole bench and to supervise the timing of operations according to a selected program. An acquisition board performs voltage, current or temperature measurements on the power supply, on the capacitor and on the coil. These measurements are made available to the μC and are used in particular to avoid overheating of the coil and to respect maximum current limits of the thyristors [12], [13], [14].

To comply with user safety requirements, electrical insulation of the stimulator versus the mains (230V/AC) and galvanic insulation between the discharging and charging circuits are very important. For these reasons, we have imposed strong constraints on electrical insulation [15], in particular between the high voltage coil circuit and the low voltage circuit. The low voltage circuit comprises the μC unit, the parameter acquisition board and the thyristor control board. A schematic diagram of the stimulator is given in figure 2.

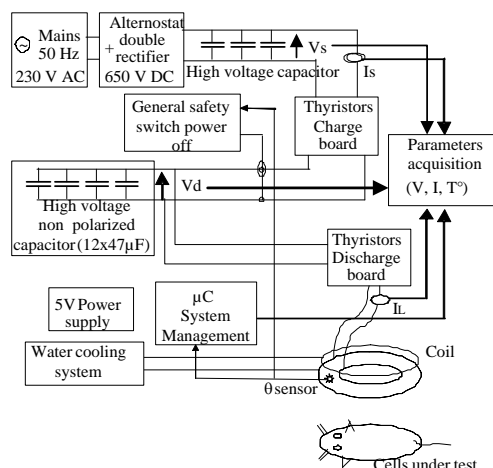

Fig 2: Block diagram

3.2 Technical specifications

The most important specifications we gave for the design of the stimulator were:

- AC/DC power supply: 230V AC/ 650V DC, primary current 6,5 A, 50 Hz.,
- AC protection: Fuse 8A
- Basic magnetic pulse waveform: damped sinusoid, either half-sine (duration 172 μs) or full-sine period: (duration 344 μs), damping factor $\alpha = 1182 \text{ s}^{-1}$, coil peak current: adjustable from 0 to 6000 A max, coil voltage adjustable from 0 to 650V, positive or negative,
- Other waveforms: (planned for 2009) double sine-pulse with 1 to 100 ms inter pulse interval, two, four and eight chained damped sine pulses
- Repetitive mode: 0 to 17 impulses / second tuneable.
- Electrical insulation: floating output (class 2)

3.3 Detailed description

a) The power supply generates a maximum voltage of 650 VDC from the mains, with a power of 1.5 kW. The main components for this supply are:

- A commercially available Alternostat 0 -230Vrms (figure 3a)
- A specially designed insulating transformer with 2 independent secondary outputs 230Vrms (ref C.E.C company- St Médard d'Eyrans -France)



Fig 3a : alternostat

- A « tank » capacitor consisting of two groups of 3 chemical capacitors, 3300 μF / 450 V (ref B44030 17S Sorelec, Cesson Sevigné, 35) each, in parallel associated in series, giving an equivalent capacitor C_s equal to 4950 μF / 900V (figure 3b).



Fig 3b : Tank capacitor

b) The discharge capacitor C_d consists of a set of 12 capacitors, $47\mu\text{F}/650\text{V}$ each, in parallel giving an equivalent capacitor of $564\mu\text{F} / 650\text{V}$ (ref B25832-C4476-K9 Sorelec, Cesson Sevigné, 35). Capacitor C_d operates as an intermediate tank for magnetic pulse generation (figure 3c).



Fig 3c: discharging capacitor block

C_d is alternately charged through a bridge of "charging" thyristors [1], [2], then discharged through the second thyristor bridge (cf. description in § 3.3.c and block diagram of Figure 2).

c) The charging block for discharge capacitor C_d consists mainly of a bridge of 4 thyristors $1300\text{V}/600\text{A}$ (ref SKT 40/12E Semikron) on heat sinks. Thanks to this full bridge [3], [4], C_d may be charged at either a positive or a negative voltage V_d . Therefore, V_d can reach a maximum voltage of $\pm 650\text{V}$.

As the equivalent L, Cd circuit is lightly damped (cf § 3.1), a quite important voltage (around 66% of the initial voltage) remains across Cd after a full-sine pulse.

However, in case of a half-sine discharge (cf § 3.2), the voltage across Cd is reversed compared to its initial polarity. In order to limit losses during the next charging cycle and to avoid overdriving the charging thyristor bridge the residual voltage across Cd must have the same polarity as the next charging voltage.

In this case, a second half-sine pulse is first automatically generated to recover the right voltage polarity. The residual voltage through Cd is thus around 66% its initial value and the Cd charge is completed up to 100%. The recharging cycle is automatically managed by the microcontroller.

In addition to this operating mode (namely a half-sine wave deliberately programmed by the user), in two other cases could the residual voltage across Cd be unfortunately reversed:

- when « powering on » the apparatus ; voltage V_d can randomly be positive or negative
- following an operating failure ; if, for some reason, one of the two half-sines will not be triggered, V_d polarity remains reversed.

In both cases, the microcontroller automatically produces a complementary half-sine wave discharge, to restore the right polarity, before the next programmed charging cycle. The default is displayed by a LED indicator manually reset by the user.

d) The discharging block consists of:

- two "head to toe" thyristors ($V_{\text{DRM}} 1300\text{V}$, $di/dt 200\text{A}/\mu\text{s}$, $dv/dt = 1000\text{V}/\mu\text{s}$) (ref SKKT 500/12E (Semikron) with their snubber circuit fixed on a heat sink cooled by ventilators and controlled by pulse isolated transformer devices (figure 4). The R_{sn} , C_{sn} snubber circuit operates in parallel with the thyristors, when switching off occurs at the end of the magnetic pulse: Indeed, the internal « Switch off » time t_d of the thyristor is such that current I_L through the coil and the thyristor reverses after crossing zero and have time enough to increase drastically before actual cut off occurs. Without a snubber circuit, the large di/dt occurring at the time of the actual cut off could generate a spike voltage higher than the breakdown voltage of the thyristor and destruction of the component could occur. [4]

Here, the switching time t_d is on the order of $10\mu\text{s}$. During this recovery time, the coil current I_L

reverses and can reach a peak value of up to 1000A. The Rsn and Csn components of the snubber are sized for a critical damping of the L, Rsn, Csn circuit and limit the spike voltage and parasitic oscillation to a limit well under the breakdown voltage of the discharge thyristors (1300V).. Thus :

$$C_{sn}=1,1nF/ 800V, R_{sn}= 1\Omega, 100W$$

For safety reasons, Rsn is oversized to be able to dissipate the power due to the residual spike voltage (i.e 100W)

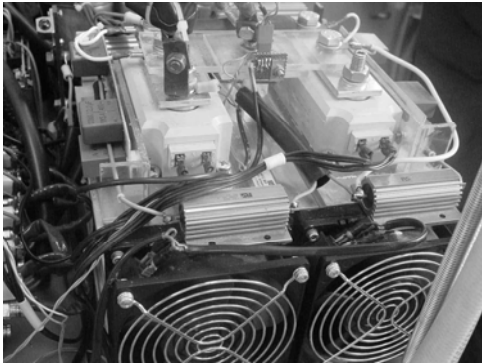

Fig 4 : Discharging thyristors and snubber assembly

- a “zero crossing coil current detection (circuit figure 4). Indeed, the duration of each half-sine is about 170 μs. In order to have a good transition between the 2 half-sines, it is necessary to trigger the second thyristor a little before the defusing of the first. The recovery time is around 40 to 50 μs.

This detection circuit has been included in the acquisition board.

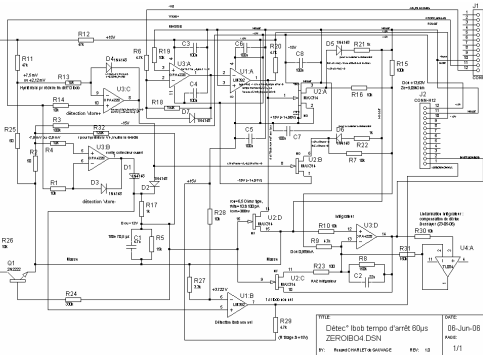

Fig 5 : coil zero-current detection circuit

The detailed electronic design of this circuit will be published in a future paper.

In case of a repetitive stimulation, Cd is discharged periodically into the coil L. A « dead time » after the discharge process, is necessary for defusing the “on” thyristor. This safety time is managed by the control board (see h).

e) The coil: [10], [11] The pulse produced by the preceding blocks is delivered to an air flat coil designed to produce a maximum magnetic induction of 2,3 tesla in close contact with it.

From paragraph b), it follows that:

$$C_d = 564 \mu F$$

With the oscillation pseudo period T,

$$T = 2\pi \cdot \sqrt{L \cdot C_d} = 344 \mu s, \quad (1)$$

it comes:

$$L = 5,3 \mu H$$

The coil (figure 6a) is manufactured in a 1,38 m long enamelled copper wire with a rectangular section of 1.6 mm x 4 mm. It has been rolled up in a plane, with a constant spacing between turns maintained by a 0.63 mm thick plastic ribbon. The coil series resistance is Rs ~11.5mΩ. The damping factor α is (according to the specifications):

$$\alpha = R_s/2L = 1183 s^{-1} \text{ (i.e. quality factor } Q \sim 8) \quad (2)$$

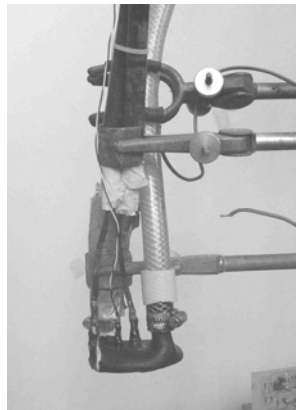

Fig. 6a: View of the coil

The internal diameter of the coil is 1.53 cm while the external diameter is 6.43cm. It is made of 11 turns. It is coated by Bi-components "Araldite" adhesive to protect it against mechanical shocks. A layer of resin makes it possible to insulate it electrically while ensuring cooling by circulation of water. The coil is coated with an epoxy resin keeping the cohesion of the coil in order to avoid its bursting under the influence of internal Laplace forces at the moment of the discharge.

f) Cooling system:

The maximum power dissipated in the coil may reach 600 W (i.e. 150 Cal/s). Cooling is done by water circulation on one side of the coil [25].

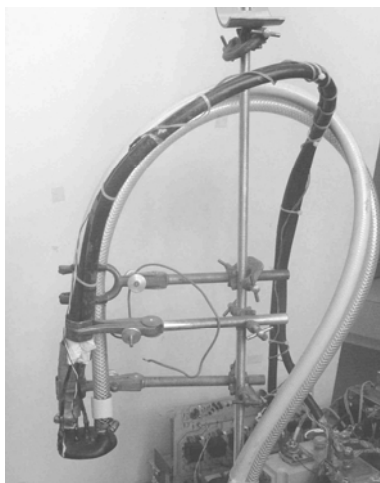

Fig 6b : cooling system

A flow of 0.15 litre/s would theoretically limit the temperature increase at 1°C above room temperature. The water flow used (0.15 litres/s) was drastically oversized for keeping the temperature of living tissues under test within physiological limits (figure 6b).

g) Parameters acquisition board:

There are nine analogue signals used for managing charge and discharge timing sequences of capacitor Cd in alternation. This ensures operational safety and protection of the components. Because of the charging thyristor bridge, the potential of capacitor Cd is floating. This means that Cd terminals are isolated from the ground of the acquisition board. Therefore differential amplification is required to measure the voltage across capacitor Cd. Two resistance dividers (ratio 1/62) are necessary for

converting the high voltage source (up to 650-700V) into a 10 V signal. This uses high voltage resistors. A differential amplifier with gain unity is used to obtain a scaled image of voltage Vd, approximately in the range $\pm 10V$. This voltage and its difference with the voltage across capacitor Cs are then compared with different thresholds to obtain different logic signals used to manage the charge and discharge of Cd. To meet TTL criteria, and at the same time to increase security furthermore, electrical transmission between the acquisition board and the μC was achieved using optical coupling.

h) Micro controller unit and parameters management:

The printed circuit board designed is based on a microcontroller MC68HC811E2. The embedded software (written in Assembler language for "real time" reasons) manages:

- in normal operating mode :
 - the pulse sequences used for triggering thyristor gates for charging and discharging Cd, (to avoid unwanted cross conduction),
 - in a next future, the double pulse cycle.
- in case of default, depending on the voltage Vd across Cd and on the configuration selected by the user:
 - the "hard" shutdown of the 650V power supply by a static relay in case of coil overheating,
 - the inhibition of any of the six thyristor gate pulses in case of thermal runaway,
 - the shutdown of the alternostat (self-fed relay) in case of simultaneous conduction of the

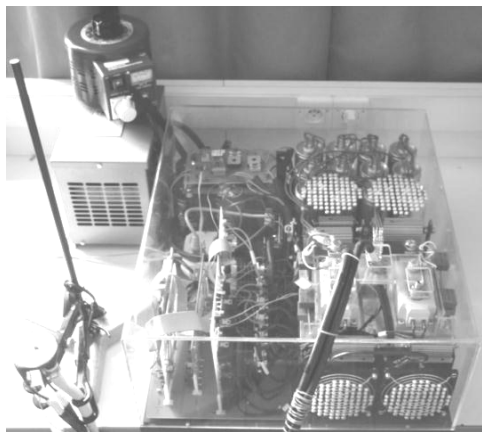

Fig 7: view of the designed TMS Stimulator

Formatted: Font: 11 pt, Complex
Script Font: 11 pt, English U.K.

thyristors in the same side of the 4 thyristor bridge,
- the detection of a failure in a discharge process,
- the security in the choice of the magnetic pulse period with an automatic limitation beyond 17,5 magnetic pulses/s.

i) Human Interface: we planned to improve the interface by adding display module and keyboard, in order to set up locally the configurations and to display the operating modes without the need of a host P.C. (in 2009)

3.4 Practical realisation

A view of the full finished TMS magnetic stimulator system is given in figure 7.

The main Plexiglas[®] box is around 54 cm wide, 25 cm high and 60 cm long. On the picture we can see:

a) Outside the box:

Top left corner:

- Insulation double output transformer (elevator) + self transformer.

Left side:

- Coil with mechanical triangular stand and its water cooling system.

b) Inside the box:

Front left side

- 3 vertical electronic boards from right to left:

Thyristor control board with thermal safety, parameters acquisition board, μ C board.

Back left side : power supply board with 6 « tank » capacitors 3300 μ F/ 450V,

Back right side: discharge capacitors 12x 47 μ F/650V

Front side: 200W limitation resistors and 2 double discharge thyristors (1 pair for future extension).

4. Validation tests

4.1 Electrical tests

Hereafter, we give some results (among others) of electric test which made it possible to totally validate our equipment [28]. Figure 8 shows the waveform across discharge capacitors Cd. The upper trace shows the voltage across capacitor Cd, initially charged to 100V, which describes a full-sine (344 μ s) before stopping.

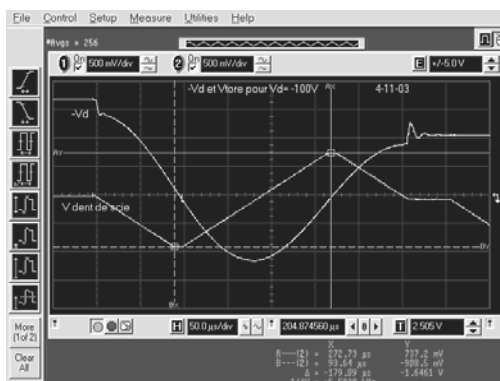

Fig 8: Full-sine waveform, Oscilloscope HP infinium

The voltage difference between the beginning and the end corresponds to the loss or damping factor in the LC circuit (horizontal scale: 50 μ s/div, vertical scale: 20V/div). The lower trace shows the “saw tooth” used for zero coil current detection.

The upper curve (triangular like) in figure 9 shows the charging current in Cd (vertical scale: 91A/div, horizontal scale: 100ms/div). The lower curve shows the logical signal used for detecting the end of the charging current, used by the μ C for enabling the next discharge cycle.

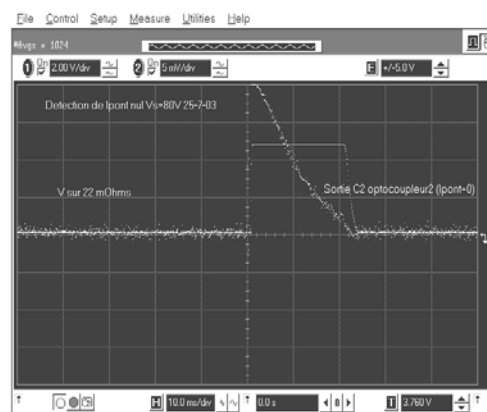

Fig 9 : Detection of the charging current through capacitor Cd (Oscilloscope HP infinium).

The logical signal switches to a high level when the charging current is present and goes low when the current falls to zero (vertical scale: 2V/div, horizontal scale: 100ms/div).

4.2 Other tests

We also did some practical tests on ourselves to verify the correct stimulation of the nervous system: For example, by applying magnetic excitation pulses on our human arm, we checked correct and non volunteer movements of the fingers.

After that, all the required tests were, of course, performed to qualify the stimulator and to guarantee total safety operations.

5. Educational assessment

Since the beginning of the magnetic stimulator project (nineties),

- 15 third year students ENSEIRB engineer electronic school, participated to the electronic design of the stimulator,
- 6 students ENSAM engineer mechanical school worked on coil cooling system ,
- 5 students BTS electronic department worked on user interface,
- 4 students ENSCPB engineer physic and chemical school and 2 students ENSEIRB participated to the design of a miniaturised version of rTMS apparatus.

These statistics reflects the multi thematic aspects of our project, and the necessity of a multi lateral collaboration between the main engineer schools of Bordeaux. They also show that a quite important number of students have regularly worked on the design of our apparatus. And significant results in term of specific knowledge transmission have been obtained.

6. Feed back from the students

In order to get some feed back about this magnetic stimulator design, we asked to the students who participated to the project, to give their technical opinion and feelings.

The result shows a global satisfaction rate of 70%. In particular, the students point out:

- a better connection "in their mind", between the abstract, heavy theory and the concrete aspects of electromagnetism and power electronic.
- a concrete and multi thematic design which allows to cross connect the different fields of knowledge.
- a high human motivation due to the bio medical goals of the subject.

7. Research laboratory feed back

Nowadays, our magnetic stimulator gives total satisfaction and is currently used for experimental research in IMS MCM laboratory. In particular, tests were performed, exposing bacteria and rat brains to pulsed magnetic fields. The resulting genotoxic study was published in a biomedical review [19]

8. Conclusion

This equipment was developed successfully at the IMS-MCM department. Given the importance of the subject, the development took more than ten years It was carried out with the aid of graduate ENSEIRB and ENSCPB, ENSAM students. It was an opportunity to share and transmit the knowledge on high power magnetic and electronic techniques to several tens students. As a possible evolution, we probably will upgrade the CPU board and try improving the users-machine interface. This development should allow an evolution towards a second generation of equipment, with a set of simplified characteristics for possible clinical applications.

Acknowledgements

R. Charlet de Sauvage is supported by INSERM, 101 rue de Tolbiac, 75654 Paris Cedex 13.

References :

- [1] MILSANT (F.). « Cours d'Electronique - Diodes et thyristors - Commandes des moteurs » (T.5). Eyrolles, 1989.
- [2] CHAMPENOIS (A.). « Alimentation thyristors et optoélectronique » RPI, 1989.
- [3] HONORAT (R.V.). « Thyristors triacs et GTO. Radio » 1987.
- [4] DALMASSO (J.L.). « Electronique de puissance – Commutation » Belin, 1986.
- [5] KUNZ (K.S.) ; LUEBBERS (R.J.). « The finite differente time domain method for electromagnetics » CRC Press, 1993.
- [6] LORRAIN (P.) ; CORSON (D.R.) ; LORRAIN (F.). « Les phénomènes électromagnétiques » Dunod, 2002.
- [7] BAILLIEU (F.) ; BLANCHARD (Y.). « Signal analogique - Capacités commutées - Architecture et concepts de base ». Dunod, 1994.

- [8] NANNAPANENI (N.R.). « Elements of engineering electromagnetics » (5e Ed.). Prentice Hall, 2000.
- [9] CHARRUAU (S.). « Electromagnétisme et Interconnexions ». Diderot, 1997.
- [10] GARDIOL (F.). « Electromagnétisme » - Vol.III. P.P.U.R., 1996.
- [11] McLYMAN (Wm). "Magnetic Core selection for transformers and inductors: a user's guide to practice and specification" (2e Ed.). Marcel Dekker, 1997.
- [12] PERRET (R.) (Dir). « Mise en œuvre des composants électroniques de puissance ». Hermès, 2005.
- [13] H. FOCH, Y. CHÉRON, R. ARCHES, B. ESCAUT, P. MARTY, M. METZ. "Techniques de l'ingénieur, D3-174: « Fonctionnement avec sources réelles des commutateurs à thyristors »
- [14] H. FOCH, Y. CHÉRON, R. ARCHES, B. ESCAUT, P. MARTY, M. METZ. "D3 173: Technique de l'ingénieur « Commutateurs de courant à thyristors »
- [15] D.MARSAN « Electrical risk management and protection » internal course, ENSEIRB 2007/2008
- [16] Le monde de l'éducation n°956 2005 pp 26-29, ISSN 0337-9213 Ed. SA Le monde
- [17] INSEE web site <http://www.insee.fr/>
- [18] Direction de l'évaluation de la prospective et de la performance, note d'information n° 07-50 p 6. ISSN 1286-9392. DEPP, Département de la valorisation et de l'édition, 61-65 rue Dutot, 75732 Paris Cedex 15
- [19] CHARLET de SAUVAGE R, LAGROYE I, BILLAUDEL B and VEYRET B "Evaluation of the potential genotoxic effects of rTMS on the rat brain and current density mapping." Clin Neurophysiology, 2008, 119: 482-491.
- [20] Ph. DONDON- J.LEGALL "Neuro linguistic programming: a personal development tool applied to the pedagogy and to the improvement of teachers/students relations" WSEAS EDU '06 16-18 december 2006 Ténérife (Spain)
- [21] N. Y. A. SHAMMAS, S. EIO, D. CHAMUND "Semiconductor Devices and their use in Power Electronic Applications" WSEAS POWER'07 21-23 Nov 2007 Venise (Italia)
- [22] E. AYDIN, A. DELICE "Experiences of Mathematics Student Teachers in a Series of Science Experiments" WSEAS EDU '07 21-23 Nov 2007 Venise (Italia)
- [23] Ph. DONDON- J.M MICOULEAU- G. LEROYER "An alternating practical pedagogical approach for sensors and actuators teaching: Learning through a multi thematic mini rolling robot design project" WSEAS EDUTE 2006 10-13 July 2006 Athens (Greece)
- [24] N. MOHAN, T.M. UNDERLAND, W.P. ROBBINS "Power Electronics: Converters, Applications, and Design, 2nd Edition" ISBN 0-471-58-408-8 Ed. John Wiley & sons
- [25] R.REMBOURG "Thermal Design of Electronic Equipment (Electronics Handbook Series)" ISBN 0-8493-0082-7 CRC Press LCC 2000, N.Wcorporate Blvd Florida 33431
- [26] CHEN R, CROS D, CURRA A, DI LAZZARO V, LEFAUCHEUR JP, MAGISTRIS MR, MILLS K, RÖSLER KM, TRIGGS WJ, UGAWA Y, ZIEMANN U. "The clinical diagnostic utility of transcranial magnetic stimulation: report of an IFCN committee" Clin Neurophysiol. 2008, 119:504-532.
- [27] KLUGER BM, TRIGGS WJ. "Use of transcranial magnetic stimulation to influence behavior." Curr Neurol Neurosci Rep. 2007, 7: 491-497.
- [28] M.MANN, B.GUTHEIL, J.ZASTRAU, P.WEISS "Electromagnetic Field Measurements - Means of Verification" WSEAS POWER'05 16-18 Dec 2005 Tenerife (Spain)
- [29] K. FERTALJ, N. VUCETIC "Challenge of Knowledge Management: From Theory to Practice" WSEAS ICOSSSE '05 16-18 Dec 2005 Tenerife (Spain)