

The Vitals Signs data Monitoring via GPS Navigation System

S.NOIMANEE, T.TANKASIRI, K.SIRIWITAYAKORN, J.TONTRAKOON

Department of Computer Engineering
Chiang Mai University
239 Huay Kaew Road, Muang District, Chiang Mai 50200
THAILAND

suranan@chiangmai.ac.th, tawee@chiangmai.ac.th, kingkeo@chiangmai.ac.th,
j-rapong@chiangmai.ac.th
<http://202.28.27.11/~suranan>

Abstract:- The paper presents a health data monitoring and transmitting system for chronic or after heart operation falls at home-site of patient. It consists of vital signs measurement such as electrocardiogram, heart rate, and blood pressure and body temperature in real-time etc. The proposed system can monitor the patients and emergency communication with long-distance transmitting system via global positioning system engine board. A prototype of this system has been developed and implemented. It has been real tested by specific physician at Maharaj hospital, Chiang Mai. The system enables the patients to do the real-time monitoring his/her vital signs conditions and examine other kinds of the patient's data from the computer database for 24 hours each day and the hospital's monitoring centre can enables the patients position and vital signs data. The results from this research will enable the local industry to manufacture the instruments with high reliability to be used in Thailand. At a much lower cost than the imported ones.

Keyword:- vital signs, heart rate, blood pressure, body temperature, chronic patient, hospital's monitoring centre.

1. Introduction

Several new equipment of biomedical devices such as portable medical devices have been designed during the past decade. Combined to the recent proliferation of wireless communication solutions, this presents exciting opportunities for the development of personal electronic health. For example, in western Europe and the United States, chronic patients are currently using personal digital assistant (PDAs) to collect and send critical medical data to a follow-up center or to their attending physicians who also have a similar handheld device connected to Internet by means of a wireless general packet radio services (GPRS) enabled cellular mobile phone[1]. The European EPI-MEDICS project [2-4] has developed an easy-to-use, low-cost Personal Electrocardiogram Monitor (PEM) having the capabilities of recording anywhere and anytime a simplified but of professional quality ECGs; analyzing the successive ECGs of a given patient with reference to a baseline ECG stored in a memory card embedded in

the personal ECG monitor: PEM detecting in almost real time the onset of an infarction or arrhythmias that are risky for the patient's health; and automatically transmitting an alarm message together with the ECGs and the patient's personal electronic health record (PHR) to the nearest emergency center, 24-hour call center, or alarm server that in turn will send a short message service (SMS) to the attending physician to warn him of the alarm message arrival as shown in Fig. 1. Now for Fig. 1 shows structure of the EPI-MEDICS project concept. The PEM may be used on demand at different occasions at home, at work, or during a trip. Depending on the alarm level or on the scenario of use, the alarm message and the vital signs such as ECGs may be automatically sent together with the embedded PHR via a standard transmitter-enabled, GSM-compatible cellular mobile phone to an emergency call monitoring centre or to the attending cardiologist. Major alarms are automatically transmitted to the nearest hospital's emergency call center.

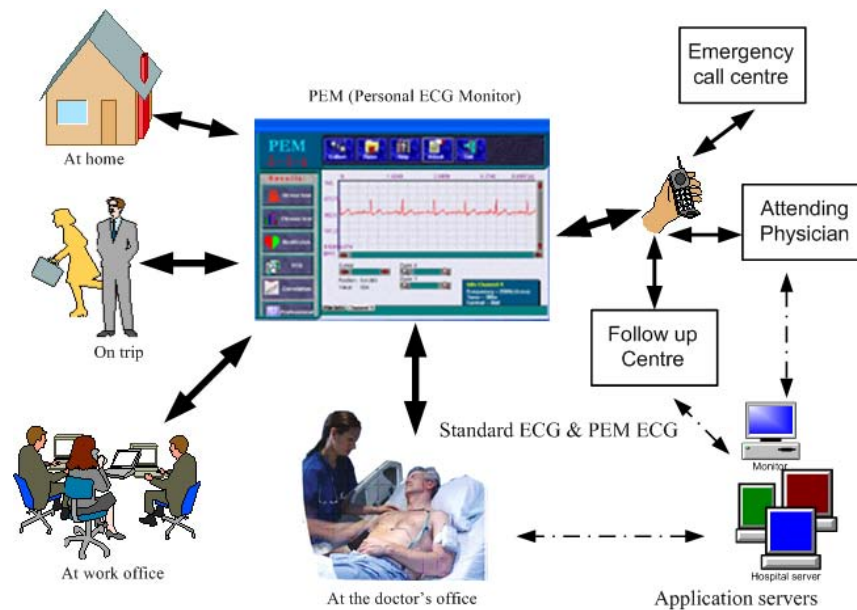

Fig. 1. Structure of EPI-MEDICS project.

To offset the relatively slow speed of technology's transmissions (which depends on the quality of the transmission and the traffic intensity and may take from 30 seconds up to a few minutes), we designed an application software running on the call center personal computers that displays the incoming information as soon as received [4]. The data transmitted by the PEM are sent in the following order:

- (1) alarm message indicating the reason and the severity of the alarm;
- (2) patient demographics and localization;
- (3) ECG that triggered the alarm (hereafter called the last ECG);
- (4) the patient's PHR, especially his cardiac history and risk factors;
- (5) if available, the most recent baseline ECG (also called the reference ECG);
- (6) clinical symptoms (if the patient or an assisting person had the time to document them); and
- (7) the second last ECG (if available and specified in the settings).

The coordinating physician in the ambulance coordinating center and the cardiologist in the emergency center can display or print on demand any received information, call back the patient on his mobile phone, and forward the received ECGs and the PHR to the

relevant cardiac center for action or advice [13]. In case of a medium alarm level (suspicion of ischemia or atypical arrhythmia), all information is sent to and temporarily stored on an alarm server as shown in Fig. 2, that automatically sends an SMS to the attending health professional cardiologist or general physician stored in the patient's contact list of the memory card. The SMS provides information about the reason and the level of the alarm, the patient's mobile phone number, the URL of the alarm server. The structure of hospital's monitoring centre is illustrated in Fig. 2 and block diagram in Fig. 9. If medium alarm scenario, the PEM system sends the alarm message together with the last recorded ECG, the reference ECG, and the patient's electronic health record (EHR) to the PEM alarm server, which in turn sends an SMS to the attending physician. The latter accesses the alarm server that automatically formats the data according to the type of equipment (PC, Notepad, etc) used to connect to the alarm server and takes the appropriate actions.

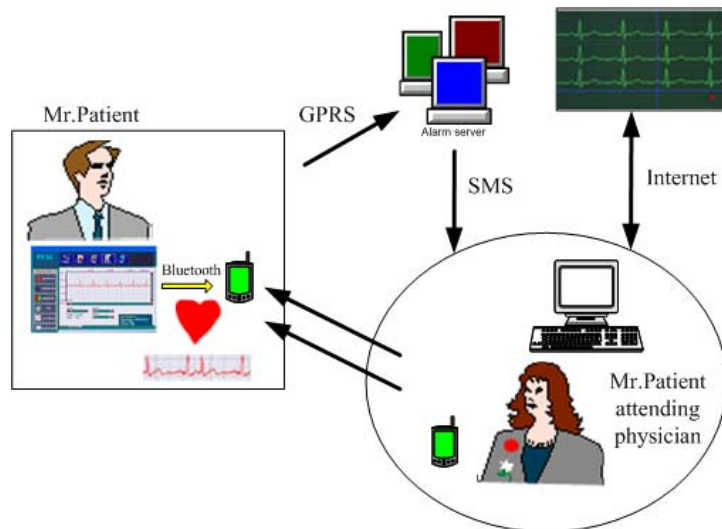

Fig. 2. Structure of hospital's monitoring centre.

2. System Implementation

We have developed a portable measuring system that combines the heart rate, blood pressure, body temperature, ECG and SPO₂. This system let the physician able to know patient's scenario on the computer screen by GPS engine board as show in Fig. 4. It also includes emergency help function. When the patient feels uncomfortable, he could press the

emergency help button for help and asking for the physician prompt assistance. In the same time, the vital signs data recorded will be sent to hospital's monitor centre in the physician's computer via UHF radio transmitter or GSM cellular mobile phone. In Fig. 3 indicated the monitoring and transmission system of the vital signed data of chronic patient at home site.

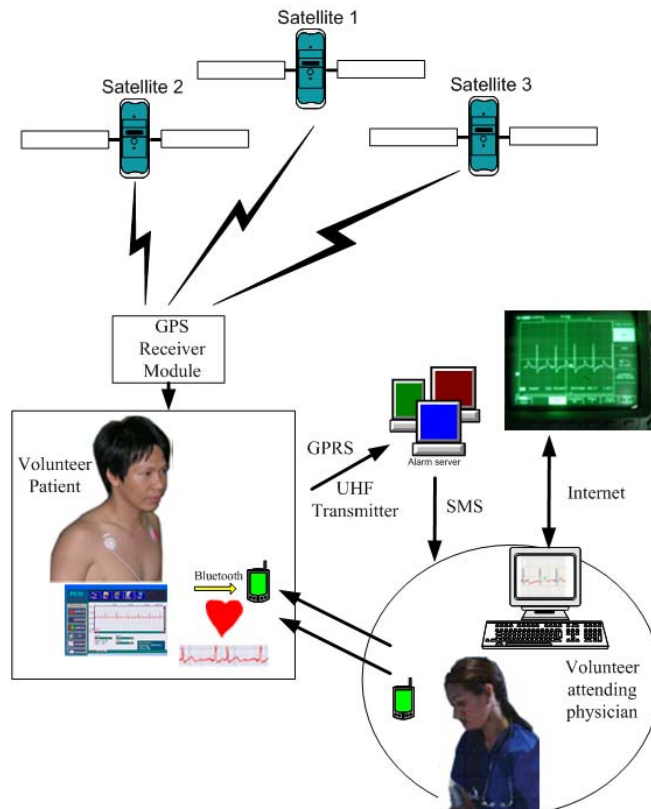

Fig. 3. The structure of overall system.

The system measures vital signs such as the heart rate, blood pressure, SPO_2 , ECG and body temperature of the patient and save them in to computer memory. Later, all the vital signs data will be sent to the physician's

computer at the hospital's monitor centre by cellular mobile phone. The vital signs data in the physician's computer will be rearranged and kept in the vital signs data files. It will become useful information for the physicians.



Fig. 4. GPS receiver engine board for report the position of patient.

2.1 PEM Structure

The overall structure of PEM system is shown in Fig. 5. The vital signs monitor is located at the user's home and the central monitor at the hospital. Information exchange between the home user and the treating physicians is via the cellular mobile phone network. The home unit consists of four components are ECG detector and transmitter that is carried by the user, a body temperature monitor, heart rate monitor, and a personal digital assistant (PDA) monitor. The vital signs detectors are development by our researcher group at Chiang Mai University but the PDA monitor and GPS engine board are commercial products. The ECG detector used in this system is a three-lead wireless device, capable of transmitting ECG signals within a 1 km radius, which is the typical apartment size in Chiang Mai University. The heart rate monitor was project from R-R intervals of ECG graph and calculated by computer software, and it stores in memory the last 10 measurements, including the time. The PEM monitor has an GPS's antenna to receive the navigation signal from 3 satellites and send signal transmitted from the PEM carried by the user. There are 3

input and output ports on the PEM: the input body temperature wire, the communication wire for the cellular phones network, and the ECG data input wire. The prototype of the PEM home monitor is illustrated in Fig. 6. The data stream of this monitor in physician computer screen is shown in Fig. 7. When the monitor receives the vital signs signal, it first digitized. Then, the digitized vital signs such as ECG data are displayed and processed by an arrhythmia analysis algorithm to search for abnormalities in the current ECG. The on-line arrhythmia analysis algorithm is able to recognize seven abnormalities. A set of alarm thresholds is predetermined for the individual user. Whenever an abnormality of the ECG data currently being analyzed exceeds the alarm threshold, the data transmission process is initiated. This transmission process includes packing the data into a specified format and initiating the modem that transfers the data packet via cellular phones network to the hospital's monitoring centre at the hospital. For heart rate monitoring, it had calculated from R-R time interval and send to the hospital's monitoring centre in the same time with body temperature. After receiving the

both heart rate data and body temperature data, the monitor packs the data into a specified format and transfers the packet to the

hospital's monitoring centre. The patient can switch the working status of the monitor via a push buttons.

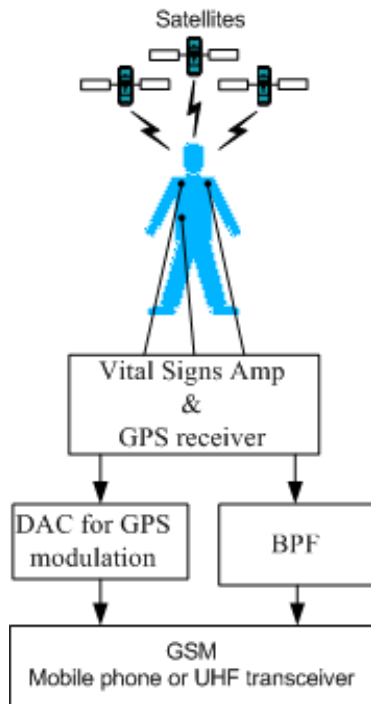

Fig. 5. Overall structure of PEM monitor.



Fig. 6. The prototype of the PEM monitor.

2.2 GPS Navigator System

The GPS navigator system consist of 4 paths of electronic circuits are:

1. GPS receiver engine board.
2. digital to Analog converter (DAC).

3. clock circuit for DAC

4. frequency of 930 MHz Transceiver/GSM cellular phones

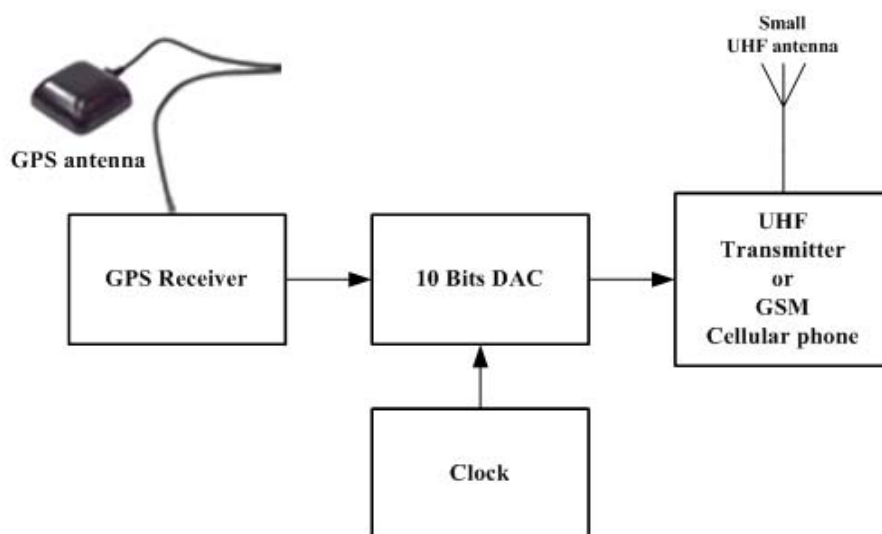

Fig. 7. Block diagram of GPS transmitter System

2.2.1 GPS receiver engine board

In system use GR-82 GPS module that interface with a microcontroller for reading data of latitude N and longitude E. This module can be receive signal 20 channel of satellite and use NMEA V2.2 (4800, 8, N, 1) protocol for interface with microcontroller. Data output of module GR-82 has data of latitude N and longitude E in sentence as follows. “ \$GPRMC,103828.047,V,0753.4876,N,09821.0235,E,0.00,,190806,*,05 ” We can description sentence for all GPS data in Table 1.

Table 1.
Description sentence for all GPS data.

Name	Example	Units	Description
Message ID	SGPRMC		RMC protocol header
UTC Position	161229.487		hhmmss.sss
Status	A		A=data valid or V=data not valid
Latitude	3723.2475		dd mm.mmmm
N/S Indicator	N		N=north or S=south
Longitude	12158.3416		ddd mm.mmmm
E/W Indicator	W		E=east or W=west
Speed Over Ground	0.13	Knots	
Course Over Ground	309.62	degrees	True
Date	120598		dd mm yy
Magnetic Variation		degrees	E=east or W=west
Checksum	*10		
<CR><LF>			End of message termination

The GPS receiver engine board is commercial product. It used in this system is around 1.575 GHz frequencies in super high frequency (SHF) band, capable of receiving positioning signals from 3 satellites within a 1 m tolerance, which is the typical apartment size in Japan. The picture of the portable GPS receiver engine board is shown in previous Fig. 4.

2.2.2 Digital to Analog converter (DAC)

The output of a GPS engine board consists of digital voltage waveforms form MAX232 IC that is RS232 standard voltage. This digital waveform is received by the digital-to-analog converter (DAC) which translates it into a sequence of analog, each representing the magnitude of the voltage at a particular instant of time. The analog signal can be either transmitted immediately to the host computer in the case of direct observation, or stored in the on memory chip for analysis at a later time.

2.2.3 Clock circuit for DAC

The clock signal that drives the DAC produces a considerable amount of signal at the fundamental and overtone frequencies. Depending on the crystal being used, the clock frequency can oscillate range of 4MHz. This can interfere with the sampling of higher frequencies, resulting in the clock being coupled with the data signal. Capacitor will reduce the effect, but it will still exist to some extent.

2.2.4 Frequency of 930 MHz Transceiver/ GSM cellular phones

The structure of GPS transmitter system is shown in Fig. 7. The GPS receiver engine board has antenna to receive the position signal from the satellite transmitted that signal to hospital’s monitoring centre. Before transmitting GPS signal, it first digitized. Then, the digitized position data are converted from digital into analog signal carried by the PIC family microcontroller. And reconverted to digital for feeding to GSM cellular phones or UHF transmitter. Fig. 9 shows the block diagram of receiver path at the hospital’s monitoring centre. They consist of UHF receiver or GSM cellular phone, 10 analog to digital converter (used PIC family microcontroller), PC communication IC, and serial port of personal computer.

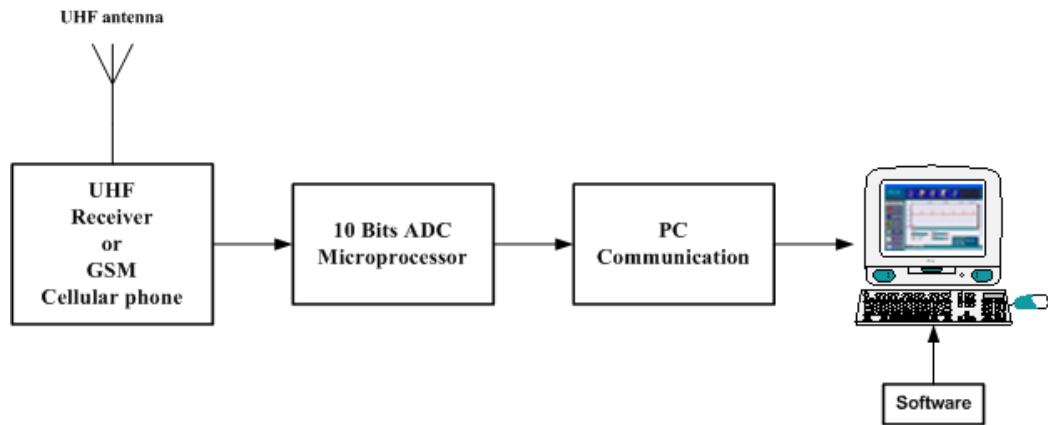

Fig. 9. Block diagram of receiving system at hospital's monitor centre.

2.3 Structure of Software

Computer software for vital signs plotting graphic and display position of the patient consist of 3 paths of component are:

1. receiving all vital signs data and display on the physician's computer screen at the hospital's monitor centre.
2. display latitude, longitude and corrected of GPS data

3. current scenario position of patient shows in map at computer screen

1. Receiving all vital signs data and display on the physician's computer screen at the hospital's monitor centre.

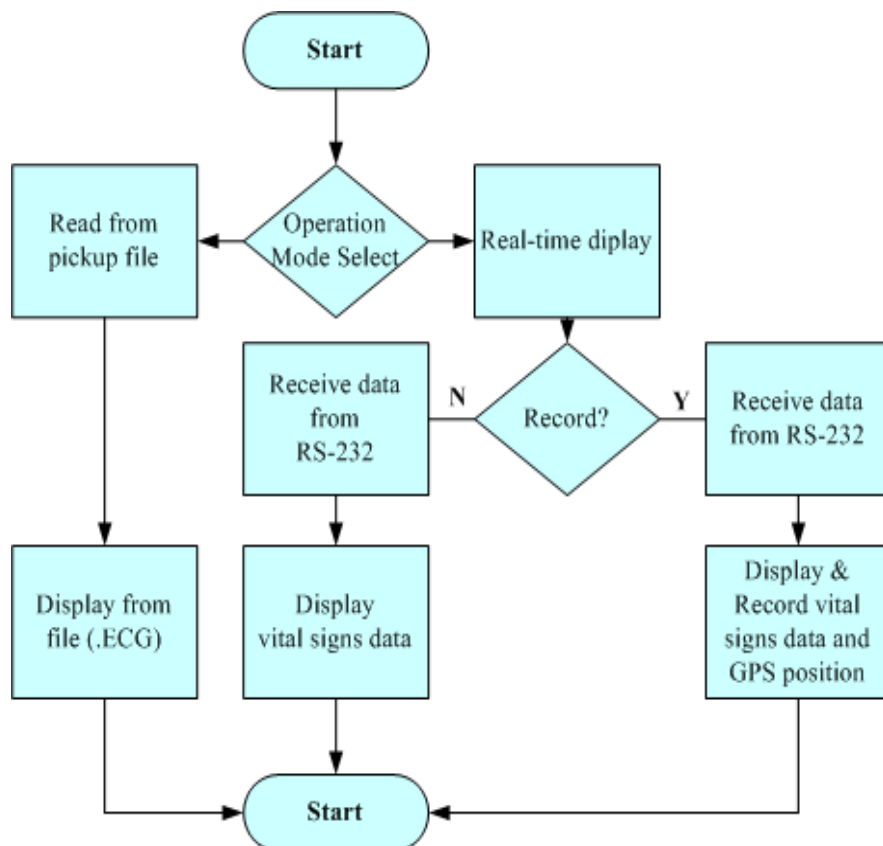

Fig. 10. Algorithm receiving vital signs from hardware and display at the physician's computer screen.

2. Display latitude, longitude and corrected of GPS data

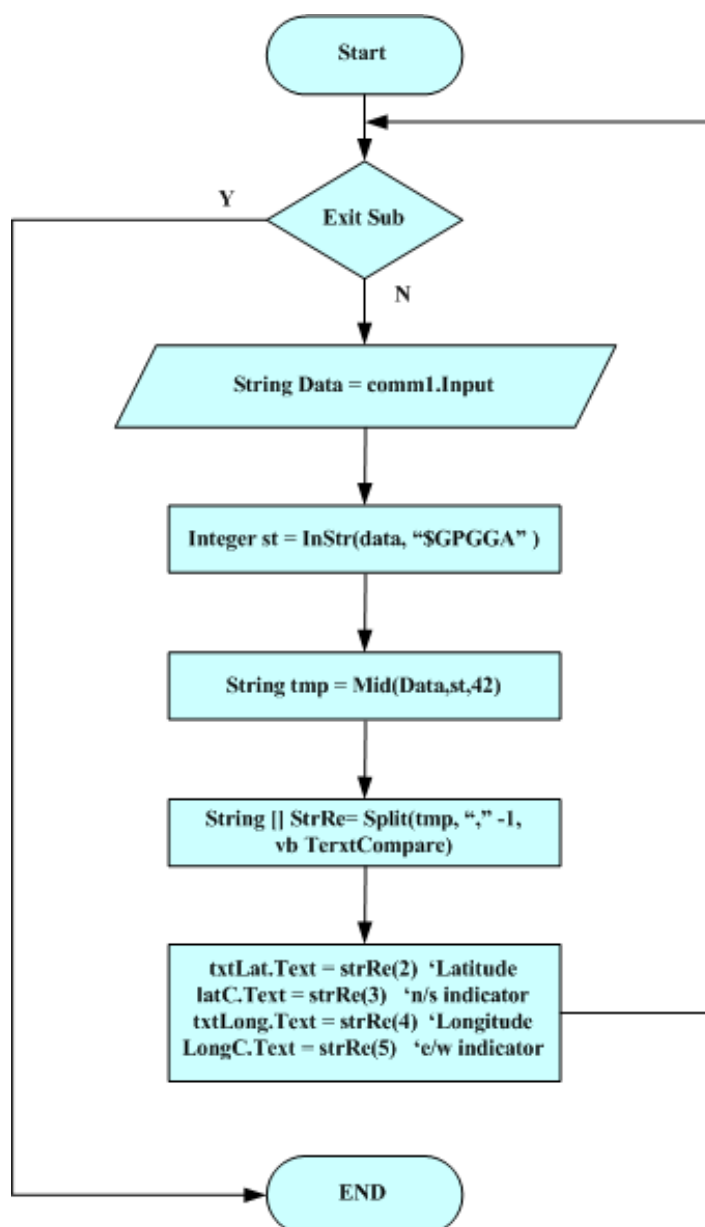

Fig. 11. Algorithm of word cutting from GPS data from GPS receiver engine board.

3. Current scenario position of patient shows in map at computer screen

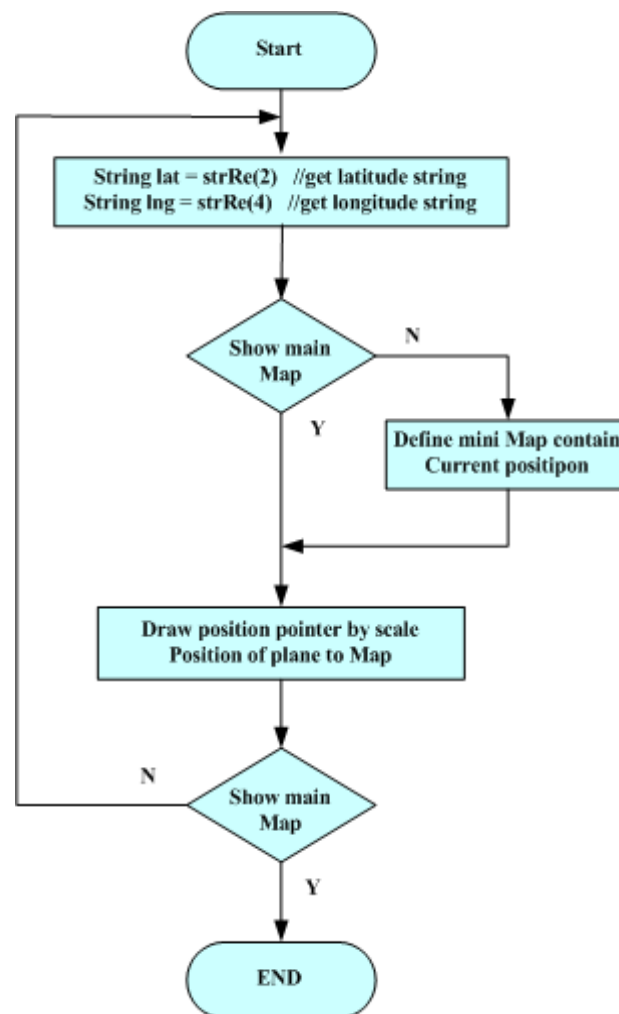

Fig. 12. The algorithm of position displayed of patient in the main map and sub map

3. Result and Conclusion

A generic PEM circuit has been developed which acquires data from a medical transducer and transmits it locally to the home-based system. To date wireless vital signs monitoring over the cellular phone network have been implemented and a demonstration blood pressure monitoring system will shortly be available. Authorized users (medical personnel) may remotely access this system to view and edit multiple windows that illustrate current data as monitor graphs, longer term medical charts, patient care plans, current medication and a critical-limits file for alerts. It is also possible to provide automatic notification of unusual changes in monitored data. If certain parameter trigger levels are breached, then alert messages may be initiated

and displayed to appropriate medical staff. Because the increasing numbers of the chronic patients, it becomes an important topic to develop a complete system. Having PCM system not only let the patient's physical condition is under control, but also can decrease the coast of taking care of the patients. It will also give the patient family a relief. How ever, there are many kinds of long-term illness. The physical condition of the chronic patients is quite different from one another. Our future prospect is to invent different kind of supervising systems for different kinds of long-term illness patients.



Fig. 13. Volunteer patient with wireless PEM.

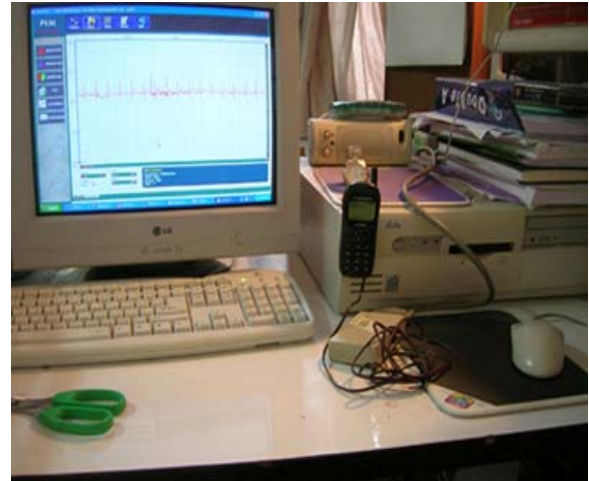

Fig. 14 Vital signs waveform display

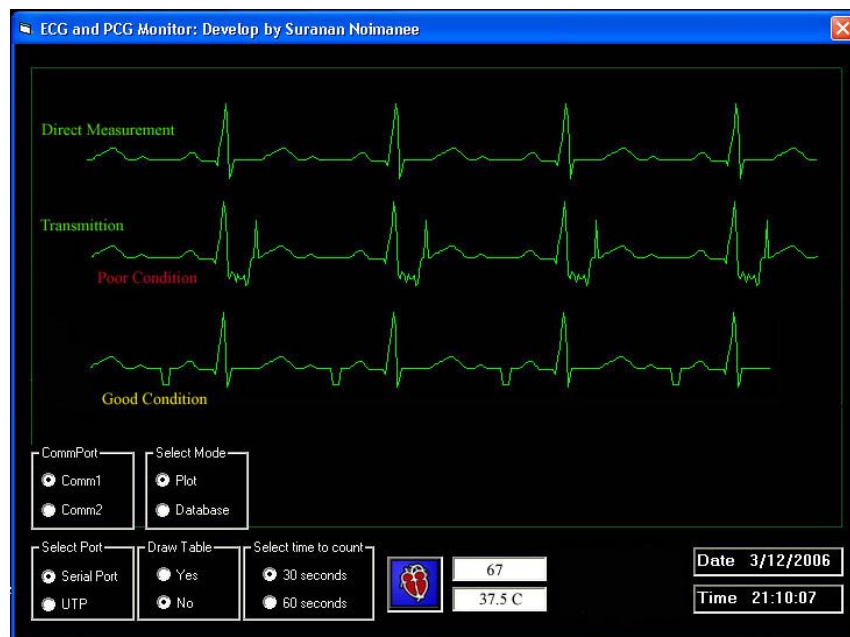

Fig. 15 . The vital signs data stream output.

Fig. 15 shows the relationship of data stream of direct measurement (upper) vital-signed and poor condition when modulated with transmitter (middle), and good condition (lower) on the computer screen when using computer program for edited. To ease ECG signal analysis and decision-making upgrades, we developed a multiplatform ECG processing software laboratory. Decision making may also be researcher group by adjusting the rule-based logic output thresholds to the patient specificities in

function of the history of false alarms or misdiagnoses.



Fig. 16 . Show current position of patient at monitoring centre.

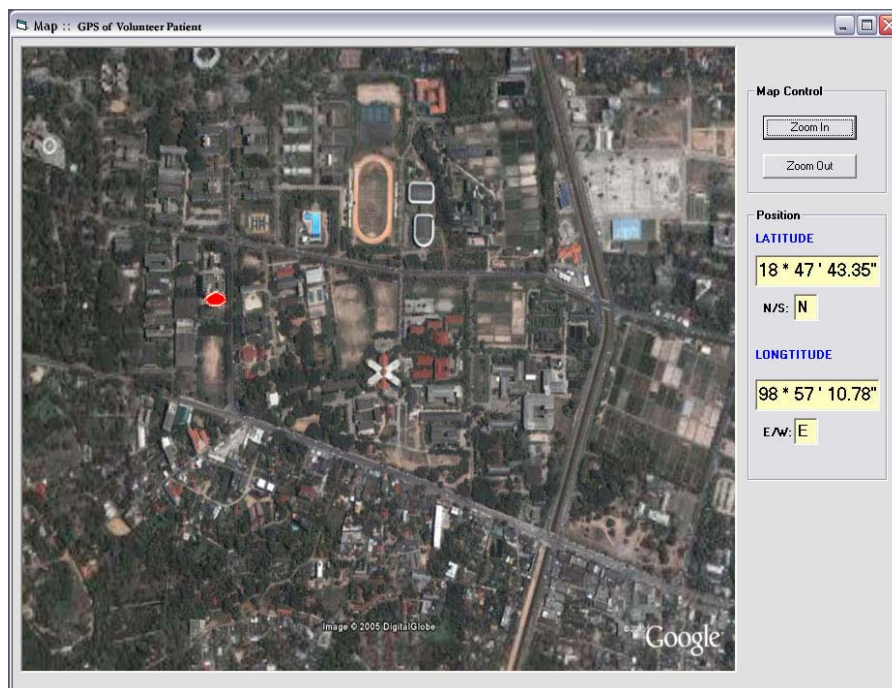

Fig. 17 . Map displaying of patient's position in Chiang Mai province, Thailand.

Fig. 14 and 16 shows the major's map with GPS navigator on physician's computer screen at hospital's monitoring centre (model in Applies computer for Biomedical Engineering Laboratory at Chiang Mai University). This system included GSM cellular phone, PEM

receiver, and desktop computer. Fig. 17 and 18 shows the minor's or sub-map with GPS navigator on physician's computer screen, it shows map displaying of patient's position in Chiang Mai province, Thailand.

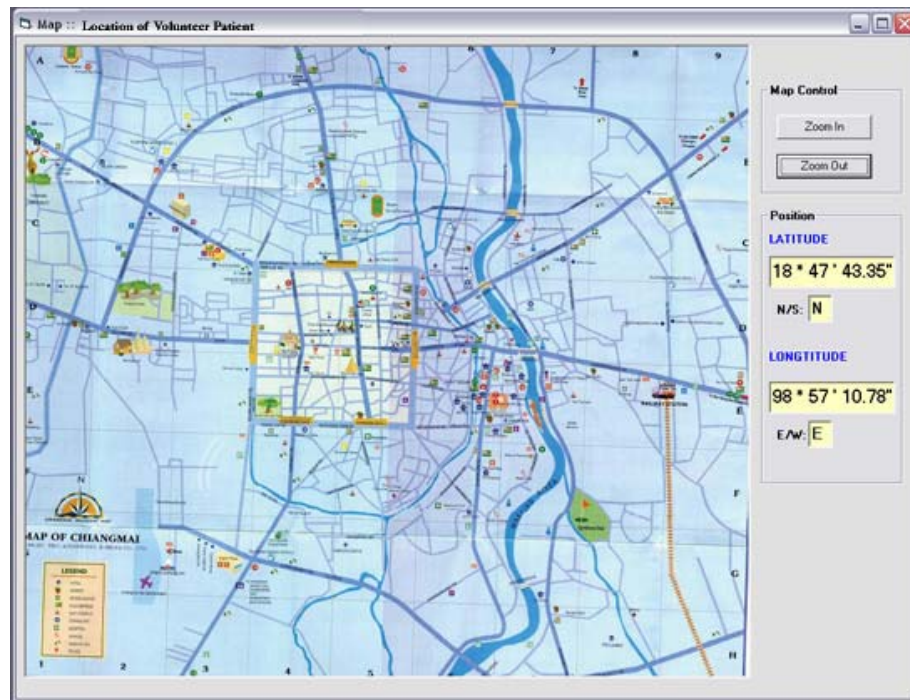

Fig. 18 . Virtual map display of patient's

4. Conclusion

The Wireless PEM System provides a wireless solution to the conventional method of measuring vital signs from a patient. The system allows for remote monitoring of patients which provides numerous advantages to both patients and to those whom are operating the logging of vital sign signals. The system designed by the team however does not fulfill the criterion of a real-time vital signs display. However the wireless link implemented (Physical Layer implemented by the author) does provide a reliable and robust communications link to the transfer of data. Results achieved with the system implemented present promising future development and design to obtain a completely wireless system. This research demonstrates that the final solution is achievable where a completely wireless PEM system would solve the inconvenience of attaching a patient to an ECG machine. Benefits of such a system include:

- Monitoring patients from home, minimizing hospital admission
- Cost
- More elegant system leading to a less cluttered bedside

- ECG data in digitized form can be used as records
- Ease of attachment to patient . easier for medical staff (less complicated placement)
- And giving patients the freedom to move around, minimizing the risk of bed-bound complications.

As it can be seen, such a system would be of benefit to society, physicians and most importantly, the patients. After decades of development of information systems and telemedicine applications dedicated to hospitals and health professionals, medical informatics is evolving to take account of new electronics health requirements, especially in the domain of home care, self-care, and cyber medicine. We can imagine a near future in which citizens and patients will use, as in this research, smart wearable technologies to produce, transmit, or access information anywhere and anytime and, above all, to act as health consumers who are responsible of their own health. They will be able to perform medical tests at the early stage of the onset of their symptoms without involving skilled personnel and call for assistance only when needed. Additional services like the flow management process of the PEM alarm messages requests to and between health

professionals are also being implemented in emergency call centers or in the informatics departments of several hospitals. All our software components will be driven by intelligent mobile agents to facilitate their communication via the XML format and to update the databases storing the patients data with new data collected at home or in ambulatory recording conditions and for efficient data retrieval. A new era has started: electronics health will become personalized, wearable, and ubiquitous.

5. Acknowledgments

The authors thank National Electronics and Computer Technology Center (NECTEC) for his invaluable assistance in funding my every research, This work was supported by Department of Computer Engineering, Department of Physics, Biomedical Engineering Center, Chiang Mai University, Chiang Mai, Thailand, and Thailand Research Fund (TRF).

References

- [1] Jerris Hedges, MD, Vital Signs Chair's Report, *MS Chair, Department of Emergency Medicine, Oregon Health Sciences University*, 120p.
- [2] Shaou-Gang Miaou and Heng-Lin Yen, Multichannel ECG Compression Using Multichannel Adaptive Vector Quantization, *IEEE Transactions on Biomedical Engineering*, Vol.48, No.10, pp.1203-1207.
- [3] Hanwoo Lee and Kevin M. Buckley, ECG Data Compression Using Cut and Align Beats Approach and 2-D Transforms, *IEEE Transactions on Biomedical Engineering*, Vol.46, No.5, pp.556-564.
- [4] Borivoje Furht and Alex Perez, An Adaptive Real-Time ECG Compression Algorithm with Variable Threshold, *IEEE Transactions on Biomedical Engineering*, Vol.35, No.6, pp.489-494.
- [5] Kevin Hung, Member, IEEE, and Yuan-Ting Zhang, Senior Member, IEEE, Implementation of a WAP-Based Telemedicine System for Patient Monitoring, *IEEE Transactions on Biomedical Engineering*, Vol.7, No.2, pp. 101-107.
- [6] Vasant Padmanabhan, John L. Semmlow, Accelerometer Type Cardiac Transducer for Detection of Low-Level Heart Sounds, *IEEE Transactions on Biomedical Engineering*, Vol.40, No.1, pp.21-28.
- [7] J.Presedo, D.Castro, J.Vila, M. Fernandez-Delgado, S.Fraga, M.Lama, S.Barro, Wireless Interface for Monitored Patients in Coronary Care Units, *Proceedings of the 22nd Annual EMBS international Conference*, pp. 1942-1945.
- [8] S.Vasudevan and K.J. Cleetus "Low Cost Telemedicine for Home Health Care," IEEE Concurrent Engineering Research Center, West Virginia University, Morgantown, WV, pp. 39-40.
- [9] KY Kong, CY Ng, K Ong "Web-Based Monitoring of Real-Time ECG Data," National University of Singapore, Singapore, pp. 189-192.
- [10] Alfredo I. Hernández, Fernando Mora, Guillermo Villegas, Gianfranco Passariello, and Guy Carrault, Real-Time ECG Transmission Via Internet for Nonclinical Applications, *IEEE Transaction on Information Technology in Biomedicine*, Vol.5, No.3, pp. 253-257.
- [11] Seung-Hun Park, Jung-Hyun Park, Se-Hyun Ryu, Taegwon Jeong, Hyung-Ho Lee and Chu-Hwan Yim, Real-time monitoring of patients on remote sites, *Proc.20th Annu. Int. Conf. IEEE EMBS*, Vol.20, No.3, pp. 1321-1325.
- [12] Gerassimos D. Barlas, Member, ZEEE and Emmanuel S. Skordalakis, A Novel Family of Compression Algorithms for ECG and Other Semiperiodical, One-Dimensional, Biomedical Signals, *IEEE Transaction on Biomedical Engineering*, Vol.43, No.8, pp.820-828.
- [13] Photios A. Anninos, Adam Adamopoulos, Athanasia Kotini, Nocholaos Tsagas, Multi-Channel Magnetoencephalographic evaluation using pTMS in Parkinson Disease Patients, *Proceedings of the 2006 WSEAS International Conference on CELLULAR and MOLECULAR BIOLOGY - BIOPHYSICS and BIOENGINEERING Vouliagmeni, Athens, Greece, July 14-16, 2006*, pp. 105-110.

[14] Marko Stamenkovi, Davorin Kralj, Environmental Communication in Health Service, *Proceedings of the 5th WSEAS International Conference on Environment, Ecosystems and Development, Venice, Italy, November 20-22, 2006*, pp.217-221

.....