

Energy Recovery Systems for the Efficient Cooling of Data Centers using Absorption Chillers and Renewable Energy Resources

ALEXANDRU SERBAN, VICTOR CHIRIAC, FLOREA CHIRIAC, GABRIEL NASTASE

Building Services Department
Transylvania University of Brasov
Turnului Street, No. 5, Brasov
ROMANIA

alexandru.serban@unitbv.ro <http://www.unitbv.ro>

Abstract: - The study develops the analytical model of an energy recovery system for the cooling of a data center using renewable energy resources. The cooling system consists of an absorption chiller, driven by the thermal energy recovered from the Data Center components and additional extra solar energy.

The paper includes general information on data centers and a detailed description of the proposed energy recovery system. Additionally, a novel design is developed using the absorption chiller and alternative renewable energy, including solar energy. The conclusions highlight the efficiency of the system and comparison to the classical solutions.

Key-Words: - data centers, solar energy, absorption chiller, air conditioning

1 Nomenclature

IT	Information technology.
CPU	Central Processing Unit.
CRAC	Computer Room Air Conditioning.
PCB	Printed Circuit Board.
PDU	Power Distribution Unit.
RAM	Random Access Memory.
UPS	Uninterruptible Power Modules

2 Introduction

Several studies focused on the need to recover the thermal energy dissipated in data centers, given the large power consumption and associated power losses. It is generally accepted across the industry that the large power hungry data centers lack efficient energy recovery systems. However, most of the prior art [1 – 7] and associated studies have focused mostly on the design optimization and analysis of these data centers, without targeting the alternative recovery of the energy losses to the ambient.

The present study fills this gap, and proposes an efficient energy recovery system used to cool the equipment and to provide an optimal ‘micro-climate’ using the energy lost by the Data Centers. When the residual energy losses from the data centers are not sufficient to activate the cooling systems, it is suggested to use supplemental energy from alternative recovery systems mainly the solar energy, when available. Similarly, the geothermal energy

and other alternative sources of energy can be used for the same purpose.

In principle, the heat dissipated to the ambient by the data center racks is used to vaporize the cooling agents and thus activate the absorption Br-water refrigeration unit and cool the water which in turn will be used to cool the data center environment. When the thermal energy received from the data centers servers is not sufficient to activate the refrigeration unit, a dual system is proposed to heat the water needed for the absorption chiller, using solar energy or any other available regenerative heat source.

The current study will provide a solution for the optimal design of the data center/server cooling systems, the appropriate selection and the functional analysis of the absorption chiller together with the complementary heat exchangers required by the overall system.

The efficiency of the system is defined in terms of the Coefficient of Performance (COP), the ratio between the recovered energy from the system and the total power dissipated by the system. The COP values can reach 0.33 for a typical system.

2.1 Data Center Cooling – General Information

The cooling infrastructure is a significant part of a data center. The complex connection of chillers, compressors and air handlers create the optimal

computing environment, ensuring the longevity of the servers installed within.

The EPA's oft cited 2007 report predicted that the data center energy consumption, if left unchecked, would reach 100 million kWh by 2011 with a corresponding energy bill of \$ 7.4 billion. This conclusion is not strictly based on Moore's law or by the need for greater bandwidth. In light of these news, the industry is turning a critical eye towards cooling, recognizing both the inefficiencies of current approaches and the improvements possible through new technologies. The information is design to assist the data center professionals who must balance the growing demand for computing power with the pressure to reduce energy consumption.

Until recently, no standard measurement existed for Data Center efficiency. The Green Grid, a consortium promoting responsible energy use within critical facilities has successfully introduced two new terms; Power Usage Efficiency (PUE) and Data Center Infrastructure Efficiency (DciE).

2.1.1 Power Usage Effectiveness (PUE)

PUE is derived by dividing the total incoming power by the IT equipment load. The total incoming power includes, in addition to the IT load, the data center's electrical and mechanical support systems such as chillers, air conditioners, fans, and power delivery equipment. Lower results are better, as they indicate more incoming power is consumed by IT equipment instead of the intermediary, support equipment.

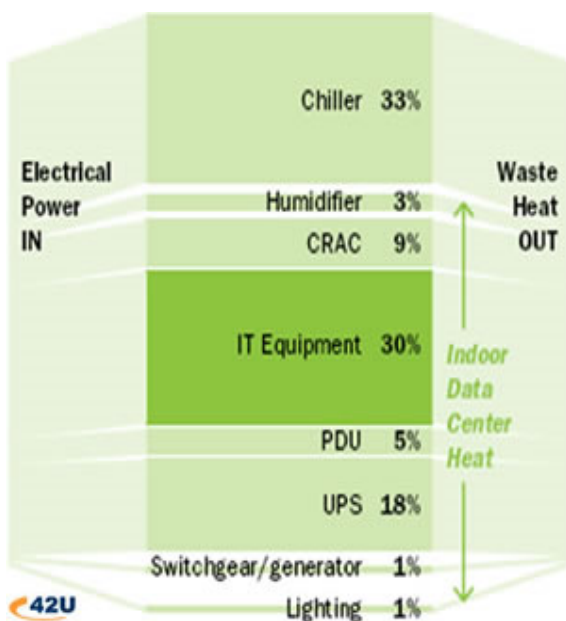

Fig. 1. Where does the energy go?
(Source: The Green Grid)

Cooling can be a major player in PUE measurement. Consider the following diagram [2], [3], where the combination of the chiller, humidifier, and CRAC consume 45% of the total energy coming into the facility.

The Uptime Institute approximates an industry average PUE of 2.5. There are no tiers or rankings associated with the values, but PUE allows facilities to benchmark, measure, and improve their efficiency over time. Companies with large-scale data center operations, like Google and Microsoft, have published their PUE. In 2008, Google had an average PUE of 1.21 across their six company data centers. Microsoft's new Chicago facility calculated an average annual PUE of 1.22.

2.1.2 Data Center Infrastructure Efficiency (DCiE)

DCiE is the inverse of PUE-Total IT Power/Total Facility Power x 100%. DCiE presents a quick snapshot into the amount of energy consumed by the IT equipment. To examine the relationship between PUE and DCiE, "A DCiE value of 33% (equivalent to a PUE of 3.0) suggests that the IT equipment consumes 33% of the power in data center."

ASHRAE released their "2008 ASHRAE Environmental Guidelines for Datacom Equipment" which expanded their recommended environmental envelope as follows:

	2004 Version	2008 Version
Temperature	20°C (68°F) to 25°C (77°F)	18°C (64.4°F) to 27°C (80.6°F)
Humidity	40% RH to 55% RH	5.5°C DP (41.9°F) to 60% RH & 15°C DP (59°F DP)

Table 1. 2008 ASHRAE Environmental Guidelines for Datacom Equipment

The cooling systems are categorized into air-cooled and liquid-cooled systems. The definitions of these categories are:

- **Air Cooling** – Conditioned air is supplied to the inlets of the rack / cabinet for convection cooling of the heat rejected by the components of the electronic equipment within the rack. It is understood that within the rack, the transport of heat from the actual source component (e.g., CPU) within the rack itself can be either liquid or air based, but the heat rejection media from the rack to the terminal cooling device outside of the rack is air.
- **Liquid Cooling** – Conditioned liquid (e.g., water, refrigerant, etc., and usually above dew point) is

channeled to the actual heat-producing electronic equipment components and used to transport heat from that component where it is rejected via a heat exchanger (air to liquid or liquid to liquid) or extended to the cooling terminal device outside of the rack.

3 Air Cooling Overview

Air cooling is the most common source of cooling for electronic equipment within datacom rooms. Chilled air is delivered to the air intakes of the electronic equipment through underfloor, overhead, or local air distribution systems. Current industry guidelines recommend that electronic equipment be deployed in a hot-aisle/cold-aisle configuration (as illustrated in Figure 1) (ASHRAE TC 9.9 2004). On each side of the cold aisle, electronic equipment is placed with the intakes (fronts) facing the cold aisle. The chilled air is drawn into the intake side of the electronic equipment and is exhausted from the rear of the equipment into the hot aisle.

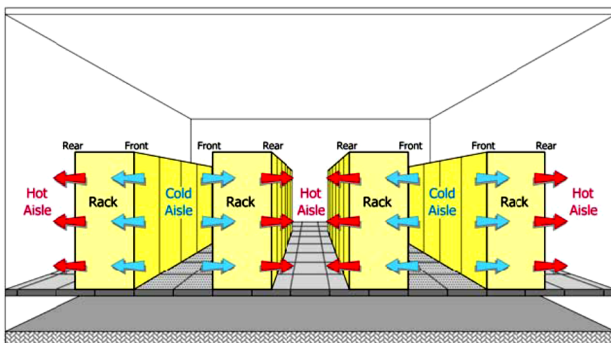

Fig. 2. Hot-aisle/cold-aisle cooling principle.

In an underfloor distribution system, chilled air is distributed via a raised floor plenum and is introduced into the room through perforated floor tiles (Figure 2) and other openings in the raised floor (i.e., cable cutouts).

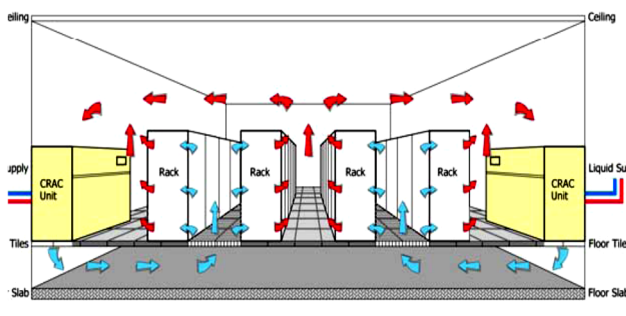

Fig. 3. Raised floor implementation using baffles to limit hot-aisle/cold-aisle "mixing".

4 Liquid-Cooled Computer Equipment

Most computers are cooled with forced air. With the increased microprocessor power densities and rack heat loads, some equipment requires liquid cooling to maintain the equipment within the environmental specifications required by manufacturers. The liquids considered for cooling electronic equipment are water, Fluorinert™, or refrigerant. Manufacturers normally supply the cooling system as part of the computer equipment and the liquid loop would be internal to the equipment. The transfer of heat from the liquid-cooled computer system to the environment housing the racks takes place through a liquid-to-water or water/glycol heat exchanger.

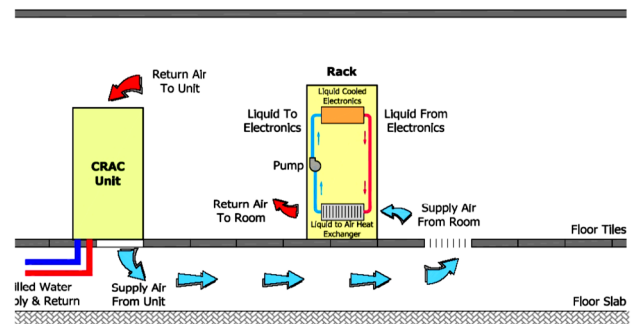

Figure 4. Internal liquid cooling loop restricted within rack extent.

Figures 5 and 6 depict the two possible liquid-cooled systems. Figure 4 shows a liquid loop internal to the rack where the exchange of heat with the room occurs with a liquid to air heat exchanger. In this case the rack appears as an air cooled rack to the client and is classified as an air-cooled system. It is included here to show the evolution to liquid-cooled systems.

Figure 5 depicts a similar liquid loop internal to the rack used to cool the electronics within the rack, but in this case the heat exchange is with a liquid to chilled water heat exchanger. Typically the liquid circulating within the rack is maintained above dew point to eliminate any condensation concerns. Figure 4 depicts a design very similar to Figure 4 but where some of the primary liquid loop components are housed outside the rack to permit more space within the rack for electronic components.

The liquid loops for cooling the electronics shown in Figures 4, 5, and 6, [1], are typically of three types:

- Fluorinerts™ (fluorocarbon liquids);
- Water (or water/glycol mix);
- Refrigerants (pumped and vapor compression).

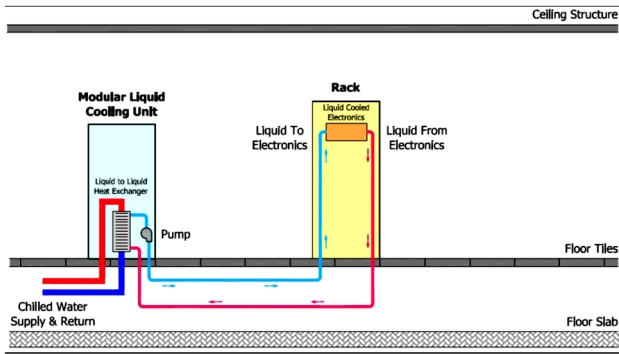

Figure 5. Internal liquid cooling loop extended to liquid-cooled external modular cooling unit.

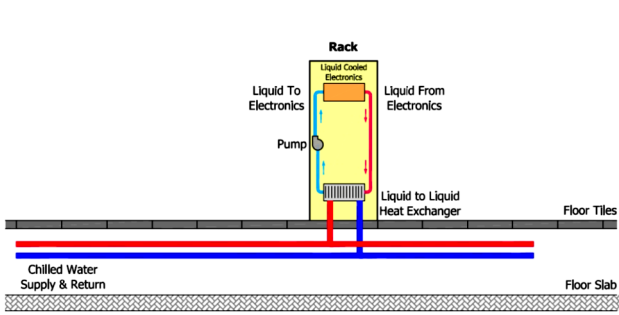

Figure 6. Internal liquid cooling loop with rack extends, liquid cooling loop external to racks.

5 Proposed Recovery Energy System

As seen in Figure 1, only 30% of the total data center power is used to drive the server activity, while the remainder is lost as heat to the surroundings. Therefore, in the paper we are proposing to increase the efficiency of the power in the system [DCiE], by recycling the lost energy and by using it primarily to cool off the system equipment. The main energy recycling process occurs at the IT level, by recycling the server rack dissipated power and using it to power an absorption based refrigeration plant preparing the water necessary for the data center cooling. Additionally, the energy from the data center ambient air is recycled as well, yet this happens at a lower temperature (and exergy levels), thus the use of over 75C heated water needed to activate the absorption chiller is not possible.

Figure 7 shows the schematic of the IT energy recycling system and the hot water preparation process for the absorption chiller, to further prepare the chilled water needed to cool off the environment (acclimatization). The system components are specified below.

The system operates as follows; the heat is taken from the data center servers while vaporizing a refrigerant (more details in next section) and transferred in a heat

exchanger by condensing the water which heats over 75 °C. The warm water enters the Absorption Chiller generator and will prepare the cold water which further enters the Air Handling Unit [AHU], which will further enable Air Conditioning for the Data Center Environment.

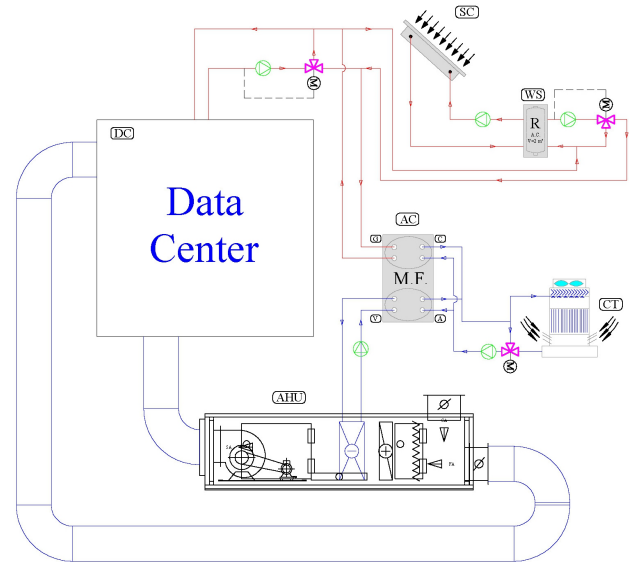

Figure 7. Heating Recovery System by cooling Servers and the Absorption LiBr/H₂O Chiller driven by this energy to Prepare Cold Water for Conditioning of the Data Center.

Legend: G – Generator; C – Condenser; V – Evaporator; A – Absorber; DC – Data Center; AC – Lithium-Bromide/Water Absorption Chiller; SC – Solar Collectors; WS – Warm Water Storage; AHU – Air Handling Unit; CT – Cooling Tower.

When the heat coming from Servers is not enough for the process, additional thermal energy from Solar Collectors [SC] is employed. This energy is stored in tank R, then is distributed to the Absorption Chiller generator to add to existing energy needed to activate the Chiller. The System has a Cooling Tower which will take the heat dissipated by the Chiller absorber and condenser Units. This heat can be reused for other practical purposes, such as the AHU air heating, also preparing utility/sanitary water.

5.1 Energy Balance for the Energy Recovery System for Proposed Data Center Cooling

The various component powers are defined as follows:

- \dot{Q}_S - server thermal power, kW;
- \dot{Q}_{SC} - solar thermal power, kW;
- \dot{Q}_G - thermal power of generator G (from chiller MF), kW;
- \dot{Q}_E - power needed to cool the air, kW

Where:

$$\dot{Q}_G = \dot{Q}_S + \dot{Q}_{SC} \quad (1)$$

Chiller MF cooling power is thus:

$$\dot{Q}_E = COP \cdot \dot{Q}_G \quad (2)$$

COP is the chiller Coefficient of Performance, value ~ 0.6 .

Also Q_{TR} is the cooling power in the Cooling Tower:

$$\dot{Q}_{TR} = \dot{Q}_C + \dot{Q}_A = \dot{Q}_G + \dot{Q}_E \quad (3)$$

Where:

Q_C = the thermal power of the condenser in the chiller unit

Q_A = the thermal power of the absorber in the chiller unit

Q_{AHU} = the thermal power of the cooling air unit in the Air Handling Unit, which is:

$$\dot{Q}_{AHU} = \dot{Q}_E \quad (4)$$

For a specific Data Center configuration with known thermal power dissipated by the servers ($Q_S = 52$ kW), need to calculate the thermal powers for the other components:

- The thermal power of the generator G: $Q_G \approx Q_S = 52$ kW;
- The refrigeration power: $Q_E = 0.6 \cdot 52 = 31.2$ kW;
- The cooling power of the solar system collector is assumed to be about half of the generator G: $Q_{SC} = 0.5 \cdot Q_G = 26$ kW;
- The thermal power of the Cooling Tower: $Q_{TR} = 52 + 31.2 = 83.2$ kW
- The thermal power in the AHU battery: $Q_{AHU} = 31.2$ kW

Referring to Figure 1, with the given thermal powers calculated, the DATA CENTER infrastructure efficiency increases from $\sim 33\%$ to $\sim 60\%$.

5.2 Details on Servers Heat Recovery Systems

The cooling refrigerant is chosen such that it will not interact chemically with the electronic chips and packages to be cooled. The refrigerant absorbs the heat from the components and vaporizes, then heats up the water in the heat dissipation process while it condenses.

Two solutions are proposed: 1) the refrigerant is re-circulated over the surface of the pumps in the

server using a pump (Figure 8 and 9) the refrigerant circulates over the servers in a natural way, using a thermo-syphon (Figure 9). For both scenarios the racks are mounted in vertical position, unlike the typical horizontal position used for the air cooled systems.

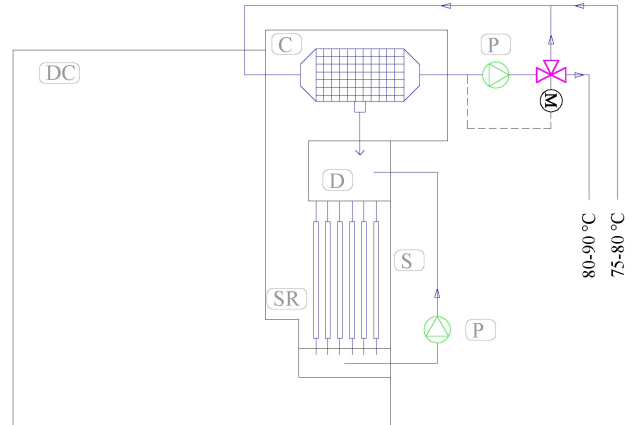

Figure 8. First proposal for heat recovery from servers, with pump circulation.

First solution with pumps (Figure 8) includes: Data Center DC, Server Plates - S, Pump Liquid - P, Liquid Distributor - D, Closed Server Room SR. The racks are placed in a room separated from the rest of the Data Center equipment. Below this encapsulated room is located the liquid refrigerant re-circulated through the distributor D via pump P over the server plaques in the form of a film. The refrigerant partially vaporizes by absorbing the heat from servers; the vapors rise towards condenser C and the remaining liquid is collected at the bottom of the encapsulated room. The vapors will rise and further condense on the surface of the tubes with water which is heating up and is further distributed to the generator of the absorption chiller system.

The water is recirculated via a 3-way throttle device until it reaches the temperature required for the solution boiling in the generator. The liquid refrigerant from condenser C returns to the system through distributor D. The power dissipated by the solution pump is negligible compared to the energy consumption inside the Data Center.

5.3 Data Center Option 1 – Design Example

A smaller Data Center is chosen, having 2 racks each with 60 server blades. Each server includes 2 CPU processors, dissipating 105W at about 90 °C temperatures. The overall thermal power dissipated by each rack is about 26 kW thus both racks will dissipate about 52 kW. Each sever is 0.3 x 0.7 square

meters, about 1 mm thick. The racks are placed vertically, forming an overall height of about 1.5 meters.

The thermal power of the condenser is 52 kW; R123 is the chosen refrigerant, with a smaller saturation pressure at phase changing temperatures compared to other refrigerants. The vaporizing and condensing temperatures are $T_o \sim T_c = 90 \text{ }^\circ\text{C}$, while $\text{CU Ps} = 6.4 \text{ bar}$. The latent vaporizing heat is 10 kJ/kg. Thus the mass flow rate needed to prepare hot water is $\dot{m}=0.37 \text{ kg/s}$.

We choose the inlet/outlet chiller generator temperatures at 80/85 $^\circ\text{C}$ as seen also in Figure 8; the hot water mass rate will be in this case $\dot{m}_w=2.5 \text{ kg/s}$. The refrigerant volumetric heat flow rate at 90 $^\circ\text{C}$ is $V=0.3 \cdot 10^3 \text{ m}^3/\text{s}$ [4.8 m^3/h]. We double the volumetric flow rate for the refrigerant recirculated in the pump, part of which will vaporize and the rest will return as liquid. The refrigerant pump will be chosen for a refrigerant volumetric flow rate of $V_t=0.6 \text{ m}^3/\text{s}$ at a pressure of 10 MPa. This refrigerant flow rate will provide satisfactory 0.5 mm coolant films on the server blades.

In Figure 9 is presented the second solution, with the refrigerant circulated via a thermo-syphon. The components details are provided in the Legend. The refrigerant vapors will rise on the server blades due to the buoyancy force, then will condense on the surface of condenser C. There are 2 solutions to achieve the upward motion of the refrigerant, one using a custom built heat tube surrounding each server blade and a second option would be to build more server blades such that the condensation could follow a separate path.

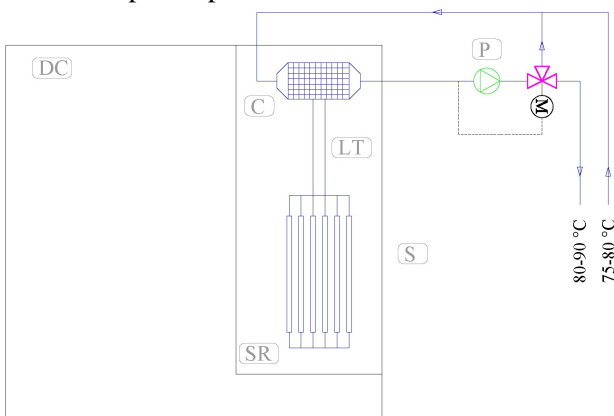

Figure 9. Second proposal for heat recovery from servers, with thermosyphon.

Second solution with thermosyphon (Fig. 9) includes: Data Center DC, Server Plates - S, Pump Liquid - P, Liquid Distributor - D, Condenser - C,

Liquid Tube with Distributor - LT, Closed Server Room - SR.

Hence, the first solution (with recirculation pump) has several advantages over the second one, such as: design simplicity, lower power consumption required to activate the pump and the reliability of the system. The system will be built and tested in order to confirm these hypotheses.

6 Conclusions

The paper presents a novel solution of recovering the thermal energy dissipated by the data center server blades, using it to prepare hot water to activate a LiBr-HSO absorption chiller to prepare the cold water necessary to further cool the data center environment. When the additional energy dissipated by the Data Center is not enough to cover the inputs necessary for the cooling process via absorption, additional energy is provided by a solar system or other renewable energy system.

The proposed energy recovery system will lead to a COP of ~ 0.6 , double of the 0.33 value for the system without recovery. The current study is purely theoretical, enabling a better understanding of what the pros/cons of building such a recovery system are to improve the efficiency; next step is to build an experimental setup to validate the proposed solution.

References:

- [1] X1. ASHRAE Datacom Series CD 2 EDITION: Thermal Guidelines for Data Processing Environments, Power Trends and Cooling Applications, Design Considerations for Datacom Equipments Centers.
- [2] X2. Cappuccio, D. (2008), Creating Energy-Efficient, Low-Cost, High Performance Data Centers. Gartner Data Center Conference, (p. 4), Las Vegas.
- [3] X3. EPA. (2007, August 2). EPA Report to Congress on Server and Data Center Energy Efficiency.
- [4] X4. McGuckin, P. (2008). Taming the Data Center Energy Beast. Gartner Data Center Conference, (p. 5). Las Vegas.
- [5] X5. Sullivan, R. (2002). Alternating Cold and Hot Aisles Provides More Reliable Cooling for Server Farms.
- [6] X6. Green Grid. (2008, October 21). Seven Strategies To Improve Data Center Cooling Efficiency.
- [7] X7. The Green Grid. (2009). The Green Grid: Home.