

Real Time Implementation of the State-PI Feedback Control Scheme for a Magnetic Levitation System

WITCHUPONG WIBOONJAROEN, SARAWUT SUJITJORN and ANANT OONSIVILAI

School of Electrical Engineering
Suranaree University of Technology

111 University Avenue, Muang District, Nakhon Ratchasima, 30000.

THAILAND

Vichupong@gmail.com

Abstract: This paper presents design and implements the state-PI feedback controller for controlling the magnetic levitation system. First, a linear model that represents the nonlinear dynamics of the magnetic levitation system is derived by the feedback linearization technique. Then, the state-PI feedback control developed from the linear model is proposed. Results are compared between the conventional state feedback technique and the proposed method. The proposed control scheme introducing an integral element to work with the gain can effectively eliminate the state errors. In addition, we practically implemented the controller in an experimental magnetic levitation system and investigated its regulating performance. The experimental results show the effectiveness of the proposed method for disturbance dampening and stabilizing the system.

Key-Words: state feedback, state-PI feedback, magnetic levitation, pole placement, system linearization, stability and stabilization

1 Introduction

Magnetic levitation technology eliminates mechanical contact between moving and stationary parts. This implies that this technique also eliminates the friction problem. Therefore, they are widely used in various fields, such as high-speed trains, magnetic bearings, vibration isolation systems and so on. Magnetic levitation systems are inherently unstable and uncertain nonlinear dynamical systems. Therefore, it is always a challenging task to construct a high performance feedback controller to fix the position of the magnetic levitation system rapidly and exactly. In recent years, many proposals have been presented in literatures based on linear and nonlinear system models for controlling this system [1-3]. The standard linear techniques are usually based upon an approximation linear model by which a linear control law can be constructed to meet the design specification. A wide variety of control methods are proposed ranging from PID and classical state feedback controls to complex nonlinear and adaptive controls. Several advanced control algorithms are applied for controlling magnetic levitation system, such as model reference control [4], robust control [5], sliding mode control [6], feedback linearization method [7] etc. Recently, state-PI feedback [8,9] has been proposed for regulation problem of an LTI system. The concept is

extended to stabilization control of a magnetic levitation system as reported by this paper is shown on Fig. 1.

In this paper we consider stabilization control of a magnetic levitation system. First, the state-PI feedback control is applied to achieve stabilization and disturbance rejection via pole-placement. Second, a linear model representing the nonlinear dynamics of the magnetic levitation system is derived by the feedback linearization. The achieved results are compared with those obtained from the conventional state feedback approach. Section 2 presents the designing of state-PI feedback controller. Section 3 gives a brief on model representation of a magnetic levitation system. Experimental results for stabilization of the magnetic levitation system follow in Section 4. Section 5 provides the conclusion.

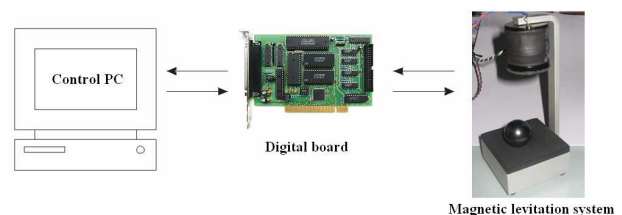

Fig. 1 Magnetic levitation system

2. Pole placement by state-PI feedback

Let's consider a delay-free completely controllable LTI system described by

$$\dot{\mathbf{x}} = \mathbf{A}\mathbf{x} + \mathbf{B}u, \quad \mathbf{x}(t_0) = \mathbf{x}_0 \quad (1)$$

where $\mathbf{x} \in \mathbf{R}^n$ is the state vector, and $u \in R$ is the control input. $\mathbf{A}(n \times n)$ and $\mathbf{B}(n \times 1)$ are the system matrix and the control gain vector, respectively. From \mathbf{A} , the characteristic polynomial can be written as

$$\det(s\mathbf{I} - \mathbf{A}) = a_n s^n + a_{n-1} s^{n-1} + \dots + a_1 s + a_0 = 0 \quad (2)$$

Where $\mathbf{a} = [a_0 \ a_1 \ \dots \ a_n]$, $a_0 = \det(-\mathbf{A}) = (-1)^n \det(\mathbf{A})$ and $a_{n-1} = -\text{trace}(-\mathbf{A})$. The control u of the state-PI feedback is

$$u = \mathbf{K}_p \mathbf{x} + \mathbf{K}_I \int \mathbf{x}(\tau) d\tau, \quad (3)$$

where $\mathbf{K}_p, \mathbf{K}_I \in \mathbf{R}^n$ are the designed gain matrices to achieve a desired closed-loop characteristic polynomial. The closed-loop system can be represented by Eq. (4).

$$\mathbf{x}' = (\mathbf{A} + \mathbf{B}\mathbf{K}_p)\mathbf{x} + \mathbf{B}\mathbf{K}_I \int_0^t \mathbf{x}(\tau) d\tau \quad (4)$$

Eq. (5) represents the closed-loop characteristic equation, while Eq. (6) represents the prescribed characteristic polynomial.

$$\det[s\mathbf{I} - (\mathbf{A} + \mathbf{B}\mathbf{K}_p) - \frac{\mathbf{B}\mathbf{K}_I}{s}] = 0 \quad (5)$$

$$\Delta_d(s) = \alpha_0 + \alpha_1 s + \dots + \alpha_{n-1} s^{n-1} + \alpha_n s^n + \alpha_{n+1} s^{n+1} \quad (6)$$

It is noticed that the n-order of the open-loop system is increased by 1 due to the integral term.

2.1 Frobenius canonical form

The pole placement problem herein considers the Frobenius canonical form of a delay-free LTI system. Eq. (7) represents the state transformation

$$\xi = \mathbf{T}\mathbf{x}, \quad \mathbf{x} = \mathbf{T}^{-1}\xi, \quad (7)$$

where $\xi(\mathbf{t})(n \times 1)$ is the transformed state variable vector, and $\mathbf{T}(n \times n)$ is the transformation matrix. The matrices $\mathbf{A}_c(n \times n)$ and $\mathbf{B}_c(n \times 1)$ are the

transformed system matrix and the control gain vector, respectively. Both matrices can be calculated as follows:

$$\mathbf{A}_c = \mathbf{T}\mathbf{A}\mathbf{T}^{-1}, \quad \mathbf{B}_c = \mathbf{T}\mathbf{B}, \quad (8)$$

where

$$\mathbf{T} = [\mathbf{q}_1 \quad \mathbf{q}_1 \mathbf{A} \quad \dots \quad \mathbf{q}_1 \mathbf{A}^{n-1}]^T. \quad (9)$$

The vector $\mathbf{q}_1(1 \times n)$ in (9) is

$$\mathbf{q}_1 = \mathbf{e}_n^T \mathbf{w}_c^{-1}, \quad (10)$$

in which \mathbf{w}_c is the controllability matrix of the system (1)

$$\mathbf{w}_c = [\mathbf{B} \quad \mathbf{A}\mathbf{B} \quad \mathbf{A}^2\mathbf{B} \quad \dots \quad \mathbf{A}^{n-1}\mathbf{B}], \quad (11)$$

and the unit vector $\mathbf{e}_n = [0 \ 0 \ \dots \ 1]^T$. The Frobenius canonical form can be expressed as

$$\dot{\xi} = \mathbf{A}_c \xi + \mathbf{B}_c u \quad (12)$$

2.2 Pole placement for state-PI feedback

The single-input LTI system (1) is assumed to be completely controllable, and \mathbf{B} is of full column rank. State feedback through a PI controller can be achieved via the gain matrices \mathbf{K}_p and \mathbf{K}_I respectively. Note that due to the integral element, one additional closed-loop pole is needed. This imposes a condition for derivation of the gain matrices, and results in an increase in the order of the system by one. The system (1) with its Frobenius form of (12) is subject to the control input

$$u = \mathbf{K}_p \mathbf{x} + \mathbf{K}_I \int \mathbf{x}(\tau) d\tau \quad \text{or} \quad u = \tilde{\mathbf{K}}_F \xi + \overline{\mathbf{K}}_F \int_0^t \xi(\tau) d\tau$$

in which $[\mathbf{K}_p, \mathbf{K}_I] = [\tilde{\mathbf{K}}_F, \overline{\mathbf{K}}_F] \mathbf{T}$. There exist the following gain matrices to achieve a desired characteristic polynomial $\Delta_d(s) = \alpha_0 + \alpha_1 s + \dots + \alpha_{n-1} s^{n-1} + \alpha_n s^n + \alpha_{n+1} s^{n+1}$

$$\mathbf{K}_p = [a_0 \quad \dots \quad a_1 \quad \dots \quad a_2 \quad \dots \quad \dots \quad \dots \quad a_{n-1} - \alpha_n] \mathbf{T}$$

$$\mathbf{K}_I = [-\alpha_0 \quad \dots \quad -\alpha_1 \quad \dots \quad -\alpha_2 \quad \dots \quad \dots \quad \dots \quad -\alpha_{n-1}] \mathbf{T} \quad (13)$$

See [8], Proposition 2.1, for proof of Eq. (13). The design procedures are as follows:

1. Calculate the transformation matrix for an n-order LTI plant using $\mathbf{T} = [\mathbf{q}_1 \quad \mathbf{q}_1\mathbf{A} \quad \dots \quad \mathbf{q}_1\mathbf{A}^{n-1}]^T$ where $\mathbf{q}_1 = \mathbf{e}_n^T \mathbf{w}_c^{-1}$, $\mathbf{e}_n = [0 \quad 0 \quad \dots \quad 1]^T$ and $\mathbf{w}_c = [\mathbf{B} \quad \mathbf{AB} \quad \mathbf{A}^2\mathbf{B} \quad \dots \quad \mathbf{A}^{n-1}\mathbf{B}]$.
2. Calculate the matrices \mathbf{A}_c and \mathbf{B}_c using $\mathbf{A}_c = \mathbf{TAT}^{-1}$ and $\mathbf{B}_c = \mathbf{TB}$ for the Frobenius form of (12).
3. Assign the closed-loop pole locations of an n-order for state-PI feedback, add one negative real pole having a fast time-constant (i.e. a negative real pole with a large magnitude)
4. Determine the prescribed characteristic polynomial $\Delta_d(s)$ having the order of n or $n+1$ corresponding to step 3.
5. Calculate the gain matrices for state-PI feedback use (13).

3. Magnetic levitation system

The magnetic levitation system is a magnetic ball suspension system which is used to levitate a steel ball on air by the electromagnetic force generated by an electromagnet. Consider a steel ball of mass M placed under an electromagnet at distance y as shown in Fig. 2. The objective of the control system is to keep the steel ball in a dynamic balance around its equilibrium point. The design of the suspension system presented here uses the electromagnetic attraction force.

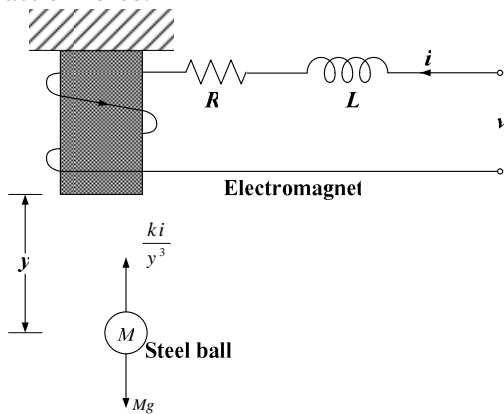

Fig. 2 Ball suspension system.

The magnetic ball suspension system can be categorized into two systems: a mechanical system and an electrical system. The ball position in the mechanical system can be controlled by adjusting the current through the electromagnet where the current through the electromagnet in the electrical system can be controlled by applying controlled voltage across the electromagnet terminals, thus the

ball will levitate in an equilibrium state. But it is a nonlinear, open loop, unstable system that demands a good dynamic model and a stabilized controller. Electromagnetic force produced by current is given by the Kirchoff's voltage law. The voltage equation of the electromagnetic coil is given by

$$v = Ri + L(y)\dot{i} \quad (14)$$

where v : input voltage,
 i : winding current,
 R : winding resistance and
 L : winding inductance.

The total inductance L is a function of the distance and given by

$$L(y) = L + \frac{L_0 y_0}{y} \quad (15)$$

Where L is the inductance of the electromagnetic (coil) in the absence of the levitated object, L_0 is the additional inductance contributed by its presence, and y_0 is the equilibrium position. Assuming the suspended object remains close to its equilibrium position, $y=y_0$, and therefore

$$L(y) = L + L_0 \quad (16)$$

Also assuming that $L \gg L_0$, Eq. (14) can be simplified as

$$v = Ri + Li\dot{i} \quad (17)$$

The principal equation for the suspended object comes by applying Newton's second law of motion. For this one degree of freedom system, a force balance taken at the centre of gravity of the object yields

$$M\ddot{y} = Mg - \frac{ki}{y^3} \quad (18)$$

where M : ball mass,
 y : ball position,
 g : gravitational constant and
 k : magnetic force constant.

The state variables are defined as $x_1 = y, x_2 = \dot{y}$ and $x_3 = i$. The state equations of the system are

$$\dot{x}_1 = x_2, \dot{x}_2 = g - \frac{k}{M} \frac{x_3}{x_1^3}, \dot{x}_3 = -\frac{R}{L} x_3 + \frac{v}{L} \quad (19)$$

Let us linearize the system about the equilibrium point $y_0 = x_{01} = \text{constant}$, which results in state vector as $\mathbf{x}_0 = [x_{01} \ x_{02} \ x_{03}]^T$. At equilibrium, time rate derivative of x must be equal to zero i.e. $x_{02} = \dot{x}_{01} = 0$ and $\ddot{y}_0 = 0$. The equilibrium point of the system is at

$$[\mathbf{x}_0] = \left[\left(\frac{ku_e}{gmR} \right)^{1/3} \ 0 \ \frac{u_e}{R} \right]^T \quad (20)$$

Thus we can write the linearized model in state space form as under;

$$\mathbf{A} = \begin{bmatrix} 0 & 1 & 0 \\ \frac{3g(gMR)^{1/3}}{(ku_e)^{1/3}} & 0 & -\frac{gR}{u_e} \\ 0 & 0 & -\frac{R}{L} \end{bmatrix}, \mathbf{B} = \begin{bmatrix} 0 \\ 0 \\ \frac{1}{L} \end{bmatrix} \quad (21)$$

The numerical values of the experimental system parameters are shown in Table 1.

Table 1 Parameters of the magnetic levitation system

Parameters	Description	Values
y_0	ball position at operating point (m)	2×10^{-2}
M	mass of steel ball (kg)	41.30×10^{-3}
R	coil resistance (Ω)	1.71
L	coil inductance (H)	15.10×10^{-3}
i_0	coil current at operating point (A)	1.05
K	constant ($\text{kgm}^5/\text{s}^2/\text{A}$)	3.10×10^{-6}
u_e	coil applied voltage at operating point (V)	1.79
G	gravitational constant (m/s^2)	9.81

4 Real time implementation

The magnetic levitation system is present with focusing on stabilization and disturbance rejection issues. Results are compared with those designed by the pervious method including Ackermann's formula [10].

4.1 State-PI feedback controller

The state-PI feedback controller is applied to the stabilization and disturbance rejection problems of

the magnetic levitation system. The block diagram in Fig.3 represents a magnetic levitation system with state-PI feedback. For comparison purposes, the method based on Ackermann's formula is also used.

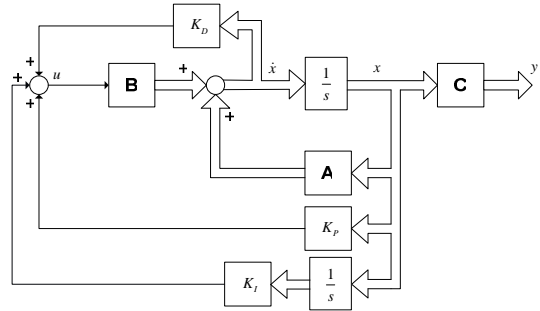

Fig. 3 Block diagram representation of a magnetic levitation system with state-PI feedback.

The magnetic system is described by the following state-variable models:

$$\dot{\mathbf{x}} = \begin{bmatrix} 0 & 1 & 0 \\ 1.4709 \times 10^3 & 0 & -9.3716 \\ 4000 & 0 & -113.2450 \end{bmatrix} \mathbf{x} + \begin{bmatrix} 0 \\ 0 \\ 66.2252 \end{bmatrix} u$$

The system is inherently unstable since it has open-loop poles at ± 38.3523 and -113.2450 . To stabilize this system, the system poles are to be placed at -10 and $50 \pm 50j$. To achieve the prescribed pole locations, an additional pole is chosen at -100 . Using the proposed method, the following gain matrices are obtained: $\mathbf{K}_P = [497.6975 \ 2.3700 \ -1.4610]$ and $\mathbf{K}_I = [48346.0449 \ 1047.3126 \ -256.6999]$. For a comparison, using the Ackermann's formula one can obtain the gain matrix $\mathbf{K}_P = [341.2612 \ 12.0375 \ 0.0490]$.

4.2 Experimental setup

We practically implement the proposed state-PI feedback controller in an experimental setup. An image of the experimental apparatus system can be seen in Fig. 4a. The coin cell batteries acting as disturbance to the ball can be controlled as shown in Fig. 4b. These experiments point out that the proposed controller is robust. In order to test the state-PI feedback controller on a real plant, the regulator was designed in Simulink of Matlab (Fig. 5). It was then implemented with the RTW of Matlab via a digital board on the real system. The digital board is a Rapcon, 12-bit input/output card [11], used with an Intel core™2 duo computer. The analog input and output blocks in the simulink scheme of Fig. 5 are input/output blocks compatible with the Rapcon digital board with sampling time 0.001s. The magnetic levitation unit is composed of

an electromagnet, of a steel ball, and of a linear hall effect sensor set that measures the position of the ball.



Fig. 4 Proposed magnetic levitation system: (a) without disturbance, (b) with disturbance

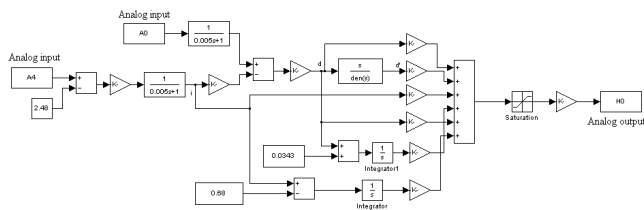

Fig. 5 Implementation of the state-PI feedback controller on Simulink.

4.3 Experimental results

The experimental results shown below were very satisfactory and demonstrated the robustness and the effectiveness of the state-PI controller. Fig. 6 shows the responses and the control input according to the proposed method, and the states are disturbed by changes in the mass at the time $t=21.5s$. It can be observed that using the proposed method the states possess very good responses, the disturbances are completely dampened out, and the control input is reasonable. With the conventional pole placement method, some states contain a large amount of steady-state errors due to disturbance as depicted in Fig. 7.

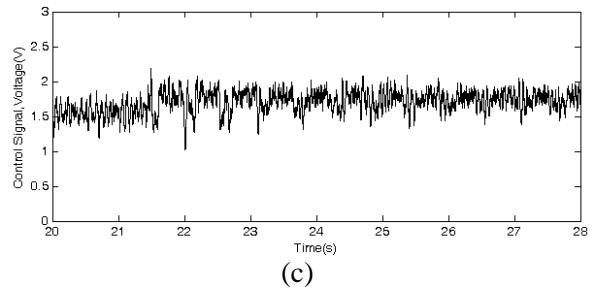
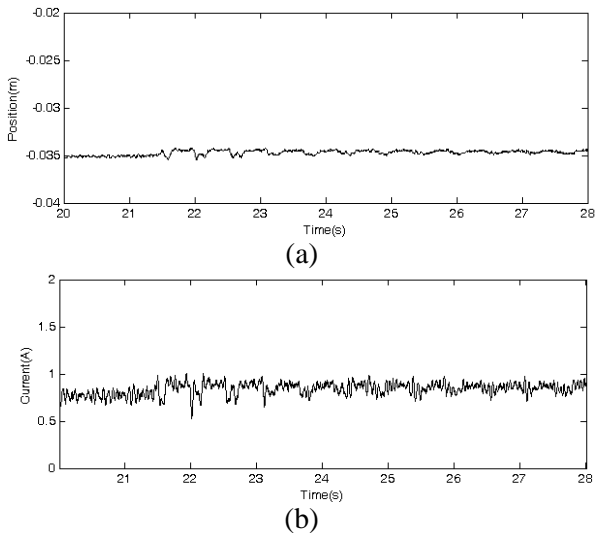

Fig. 6 Response of system states for 6% variation of the mass with the proposed state-PI feedback: (a) x_1 , (b) x_3 , (c) control signal.

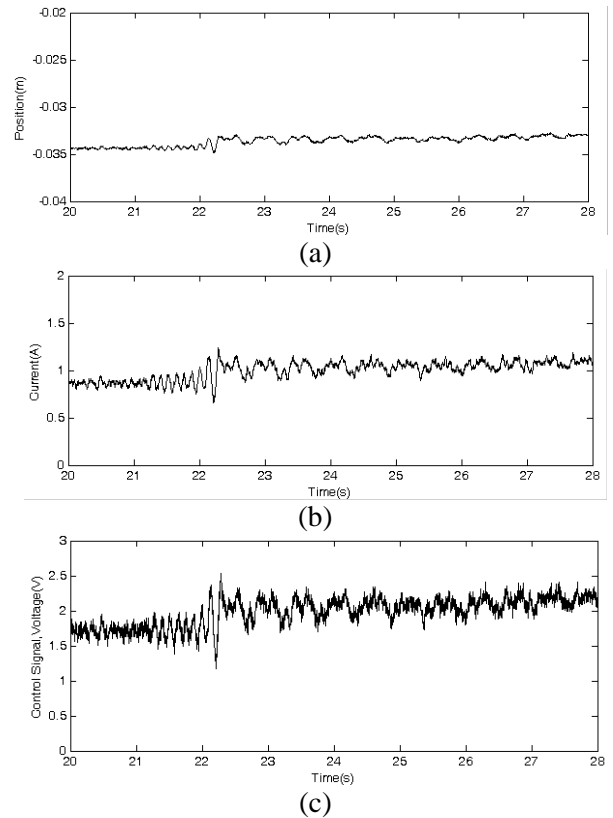

Fig. 7 Response of system states for 6% variation of the mass with the conventional state feedback: (a) x_1 , (b) x_3 , (c) control signal.

In Fig. 8, the large effect of a high step disturbance on the equilibrium position exceeds the linear range of the sensor, deteriorating the system performance. However, this effect does not occur with the state-PI feedback, as illustrated in Fig. 9, which indicates that this controller produced an appropriate action fast enough to avoid large deviations on the steel ball position. The state feedback controller could not stabilize the plant for large variations on the mass. From Figs. 8-9, one sees that the robust controllers achieve better disturbance rejection than the conventional state feedback controller and that the robust controllers perform very well in bringing the

ball back to the adopted operating position even when the system is subjected to change in the mass.

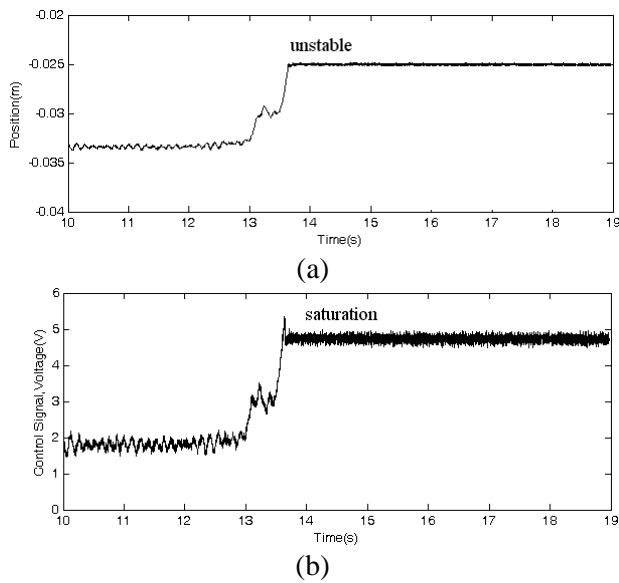

Fig. 8 Response of system states for 12% variation of the mass with the conventional state feedback: (a) x_1 , (b) control signal.

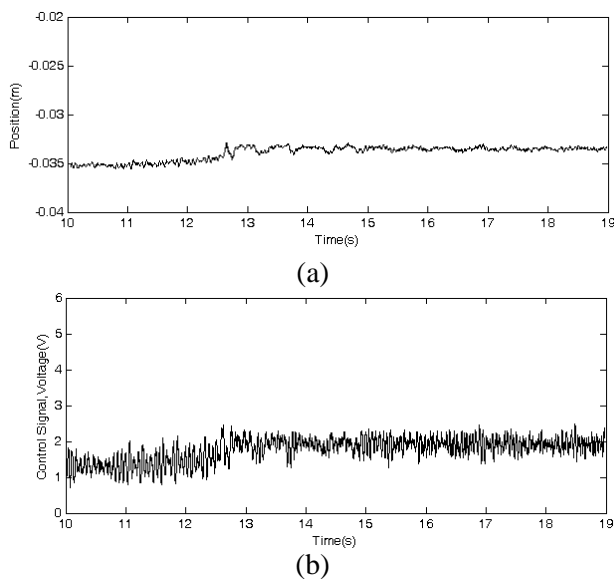

Fig. 9 Response of system states for 12% variation of the mass with the proposed state-PI feedback: (a) x_1 , (b) control signal.

5 Conclusion

We have demonstrated that the proposed state-PI feedback control is efficient when used in motion control in which the displacement, velocity and current are usually needed as feedback signals. By comparison with the conventional state feedback control, its simple structure means less effort to be made in the implementation of the controller. This is very attractive for a practical design of a feedback

control system. The magnetic levitation system has been used in this paper to practically demonstrate the effectiveness of the proposed control scheme. Experimental results indicate the state-PI feedback control scheme can result in a closed-loop system with good regulating performance as well as good robust property against high step disturbances.

References:

- [1] Z.J. Yang, K. Miyazaki, S. Kanae, and K. Wada, Robust position control of a magnetic levitation system via dynamic surface control technique, *IEEE Transaction on Industrial Electronic*, Vol.51, No.1, 2004, pp.26-34.
- [2] I. Ahmad, M.A. Javaid, Nonlinear model & Controller Design for magnetic levitation system, in *Proceeding of the 9th WSEAS International Conference on Signal Processing, Robotics and Automation (ISPRA '10)*, 2010, pp. 324 -328.
- [3] F. Gazdos, P. Dostal, and J. Marholt, Robust control of unstable systems: algebraic approach using sensitivity functions, *International Journal of Mathematical Models and Methods in Applied Sciences*, Issue 7, Vol.5, 2011, pp. 1189-1196.
- [4] D.S. Liu, J. Li and W.S. Chang, Internal model control for magnetic suspension systems, in *Proceedings of the 4th International Conference on Machine Learning and Cybernetics*, 2005, pp. 482-487.
- [5] Yang and Tateishi, Adaptive robust nonlinear control of a magnetic levitation system, *Automatica*, Vol.37, 2001, pp.1125-1131.
- [6] N.F. Al-muthairi and M. Zribi, Sliding mode control of a magnetic levitation system, *Mathematical Problems in Engineering*, Vol.2, 2004, pp. 93-107.
- [7] A.E. Hajjaji and M. Ouladsine, Modeling and nonlinear control of magnetic levitation systems, *IEEE Transaction on Industrial Electronic*, Vol.48, No.4, 2001, pp. 831-838.
- [8] W. Wiboonjaroen and S. Sujitjorn, Stabilization of an Inverted Pendulum System via State-PI Feedback, *International Journal of Mathematical Models and Methods in Applied Sciences*, Issue4, Vol.5, 2011, pp. 763-772.
- [9] S. Sujitjorn and W. Wiboonjaroen, State-PID feedback for pole placement of LTI system, *Mathematical Problems in Engineering*, ID.929430, Vol.2011, 20 pages.
- [10] K.Ogata, *Modern Control Engineering*, Third Edition, Prentice Hall, 1997.
- [11] *Real-time Rapid Control Platform*. [Online]. Available: <http://zeltom.com/products/rapcon>.