

The method of the evaluation of transport systems operation safety

PIOTR BOJAR

Mechanical Engineering

University of Technology and Life Sciences in Bydgoszcz

Al. Kaliskiego 7, 85-796 Bydgoszcz

POLAND

p-bojar@utp.edu.pl

MACIEJ WOROPAY

Air Force Institute of Technology in Warsaw

ul. Księcia Bolesława 6

01-494 Warszawa

POLAND

zem@utp.edu.pl

YURIY SHALAPKO

Khmelnytsky National University

Instytutska Str. 11, Khmelnytsky

UKRAINE

shalapko@yahoo.com

MIROSŁAW SZUBARTOWSKI

College of Engineering and Business in Włocławek

Łęgska 20, 87-800 Włocławek

POLAND

MICHAŁ BACIOR

College of Engineering and Business in Włocławek

Łęgska 20, 87-800 Włocławek

POLAND

Abstract: - Transport safety is the primary standard in the functioning of transport systems. Most of all, it is true in the case of passenger transport systems. This article introduces classification of transport systems into land transport systems (road and rail) as well as land and water transport systems (inland and sea), depending on the type of environment in which these systems carry out their tasks. Such systems fall under the class of social engineering systems of the Man – Technological Object – Environment (M – TO – E) type. Such systems are influenced by forcing factors, leading to changes in their states. Such factors may be divided into operational, outside and anthropotechnical and they influence the system on various levels, including degradation of the degree of its safety. The article attempts to evaluate the safety of the operation of transport systems on the basis of the evaluation of the safety of the transport process carried out over a defined time interval Δt . The evaluation of the safety of the carried out transport process was prepared on the basis of a set of calculated index values determined depending on the type of transport. The article presents the principles of the construction of the model of evaluation of the safety of the operation of the transport system on the basis of the evaluation of the safety of the transport process carried out by the system.

Key-Words: - system, system state, forcing factors, safety

1 Introduction

A transport system is the entirety of means and operations connected to the movement of people and cargo at a defined quantitative and territorial extent, using appropriate means of transport [1, 5, 6]. The primary goal of the system is the safety of its operation understood as its state *in which the values of the distinguished characteristics defining the system over an established time interval t are located within the predetermined limits at specific levels of the influence of forcing factors.*

System state is defined by a set of values of important features of a given system at a given moment t . If the values of these characteristics are located within predetermined limits, the system remains at safety state. However, if any significant characteristic defining the system takes up a limiting value, the so-called limit state is obtained. Crossing the limiting value of the characteristic leads to a change of state into critical, in which losses may occur due to inappropriate operation.

Under the influence of various factors, the values of these characteristics undergo a change in time leading to a change in its state. Additionally, according to the author of the article [8] *a factor is one of the ingredients influencing the changes of state of the object being the outcome of a physical and/or psychological process.* The beginning or the ending of the phenomenon at an established moment t may be accompanied by desired or undesired events. *An undesired event is an event failing to meet the expectations as to successful and conflict-free achievement of the task.* Undesired events are often a result of errors made by the operator or an incorrect organization of the carrying out of the task as well as inappropriate reactions with the environment and inappropriate technological state of the means of transport.

Therefore, the influence of forcing factors lead to changes in safety state of system operation, which, in effect, leads to a change of the level of safety of the carried out transport process.

The evaluation of the level of safety of the carried out transport process consists mostly of an analysis of the data pertaining to the number of the occurring accidents as well as the number if such accidents. The data on events in the system is gathered and processed by appropriately authorized bodies. Data on road accidents in road transport is gathered by the Police as well as authorized bodies and further serve as SEWIK (Road Accident and Collision Evidence System) database used for analysis of traffic safety in the territory of Poland. It consists of four subsystems: data collection; data

gathering, verification and processing; data reporting as well as data transfer.

Examination of accidents in rail transport is carried out by the State Committee for Inspection of Railroad Accidents, established in 2005, which fulfills its tasks in the name of the Minister of Transport and is the national investigative body in terms of the safety of community railroads. Up until that point, the data on railroad events was gathered at individual units connected to the event, which made it impossible to create a centralized database. The goal of creating such database is collection of data on accidents in relation to pointing out dangerous areas, and, consequently, introducing changes in those places.

The object of the committee activities is also determining the causes of events having occurred due to the infrastructure management or carrier fault. In terms of water transport, efforts have been undertaken in order to establish the State Committee for Inspection of Maritime Accidents. Its creation will fulfill the assumptions of the Maritime Accident Investigation Code of the International Maritime Organization (IMO) and proper introduction of the directive of the European Parliament, part of the so-called third maritime package – Erika III. The task of the Committee will be determining of the circumstances and causes of the occurrence of accident at sea, without determining the fault or assigning responsibility for such occurrence. This means impartiality in conducting inspection in cases of maritime accidents and drawing conclusions allowing, in effect, for improvement in sea transport safety. The project precisely points out to the types of maritime accidents and incidents will be examined by the committee. An important element of the operation of the committee will be the creation of Polish maritime accident database. Until now, information on an accident was published in the Information Bulletin by the Maritime Appellate Court. The Polish system of examining the causes of accidents is formed within the framework of investigation carried out by Maritime Courts in Gdynia and Szczecin, however, it goes against the currently recommended accident investigation code adopted by the IMO.

In Poland, there is the State Aircraft Accidents Investigation Committee. Among its tasks are investigations into aircraft accidents and serious incidents as well as control over examination of incidents having occurred within the territory of Poland. The goal of the examination is to establish the causes and circumstances that lead to the occurrence of the accidents. The final reports,

including the committee's suggestions, serve as the basis for the President of the Civil Aviation Office to undertake preventive measures.

The actions of all those bodies have a common task, which is to create databases within the framework of the European EUROSTAT database, comprising also the information on transport safety.

2 Examining the safety of the transport process

In order to evaluate the safety of the transport processes carried out in Poland at individual transport systems, data included in the following databases was included: the Police, the Central Statistical Office, the Euro Stat, the Civil Aviation Office as well as own research. The research included obtaining data on undesired events taking place in the time interval between January 1, 2000 and December 31, 2011.

A list of data on the occurring incidents and their effects was presented in tables 1 to 5 and represented graphically in figures 3.1 to 3.5. In table 1 the number of accidents occurring in individual transport systems over the analyzed time interval. As shown, the greatest number of events is connected with land transport systems (road and rail). The number of road accidents is several dozen times bigger than the number of accidents in rail transport. As data in table 1 shows, the smallest number of accidents occur in air transport, which makes it the safest type of transport. In all transport systems within the analyzed time interval a decrease in the number of accidents was noticed. In road transport it amounted to about 30%, 13% in rail transport, 36% in air transport, while in water transport it amounted to 11%. It is the result of the introduced safety improvement programs.

In table 2 the numbers of people killed as a result of the occurring accidents at individual transport systems were presented. The data included in the table shows that the most dangerous transport system is road transport system, where during one year more people are killed than in the remaining transport systems jointly. The data included in table 2 shows that the safest transport is water transport due to the smallest number of people killed. The case is similar in air transport.

In table 3 the number of people injured as a result of accidents occurring in the analyzed transport systems. As it is clearly shown in data from table 3, the greatest decrease in the number of injured people was noticed in land transport systems. In road transport it amounted to about 30%, while in rail transport it was 21 %. Such a

situation reflects the introduction of the assumptions of the GAMBIT program which goal is "zero accidents".

Tab.1 The number of accidents in different transport systems in Poland in the analyzed period of time [4]

	Number of accidents			
	Road Transport	Rail Transport	Air Transport	Water Transport
2000	57331	-	-	-
2001	53799	-	25	-
2002	53559	-	25	-
2003	51078	-	14	-
2004	51069	964	16	-
2005	48100	961	10	93
2006	46876	905	16	97
2007	49536	976	14	79
2008	49054	883	9	83
2009	44185	843	16	73
2010	30032	852	16	83
2011	40065	843	-	-
	99.65 %		0.06 %	0.29 %

Tab.2 The number of people killed in accidents occurring in the various transport systems in Poland in the analyzed period of time [4]

	Number of people killed			
	Road Transport	Rail Transport	Air Transport	Water Transport
2000	6294	-	-	-
2001	5534	-	5	-
2002	5827	-	5	-
2003	5640	-	19	-
2004	5712	276	21	-
2005	5444	291	12	19
2006	5243	277	21	2
2007	5583	359	22	5
2008	5437	308	47	11
2009	4572	365	24	7
2010	3907	285	125	15
2011	4189	327	-	-
	98.80 %		0.90 %	0.29 %

While analyzing the data included in tables 1 to 4, it becomes clear that the most dangerous transport system is land transport system, where about 99.6% accidents occur. The number of people killed is also the highest in land transport and amounts to 98.8%.

Tab. 3 Number of people injured in accidents occurring in the different transport systems in Poland in the analyzed period of time [4]

	Number of people injured			
	Road Transport	Rail Transport	Air Transport	Water Transport
2000	71638	-	-	-
2001	68194	-	5	-
2002	67498	-	18	-
2003	63900	-	6	-
2004	64661	689	49	-
2005	61191	694	65	29
2006	59123	502	60	8
2007	63224	633	61	15
2008	62097	574	57	10
2009	56028	564	66	10
2010	40952	483	-	7
2011	49501	543	-	-
	99.85 %	0.12 %	0.04 %	

Tab. 4 Summary of average values of the number of accidents and people killed and injured in these accidents in the various transport systems in the analyzed period of time [4]

	Transport System		
	Land	Air	Water
Number of accidents	29096	16	85
Number of people killed	3294	30	10
Number of people injured	36634	43	13

The analysis presented in the article is a comparative analysis which made it possible to illustrate the scale of the problem in individual transport systems. In order to improve the level of safety of transport in transport systems, especially in land transport, it is necessary to perform a detailed identification of accident causes and build a systematic model of the evaluation of safety of the transport under realization, taking into consideration the relations between crucial forcing factors.

The evaluation procedures for transport systems by authorized government institutions are reduced to the evaluation of the number of accidents in a given transport system as well as the number of people killed and injured in the occurring accidents. **As shown in literature, this is an ex-post evaluation, after the incident occurred, evaluating the transport process carried out by the given system.**

3 Evaluation of the state of safety of transport systems in Europe

The state of safety of transport systems in the European Union is analogous to the situation in Poland as presented in detail in chapter 2. As shown in figure 1, accidents in the “old 15” countries occur less often, however, in 2008, 177 air accidents took place, including 154 in Spain. Evaluating the number of people killed as a result of the occurring air accidents, the situation is analogous - fig. 2.

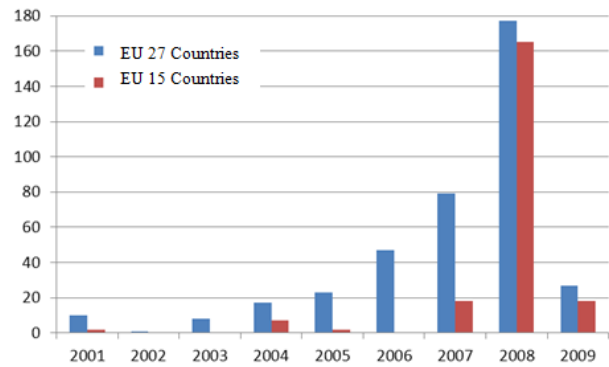

Fig. 1 The number of accidents in air transport in the EU

The above clearly shows that such a drastic number of accidents and people killed in 2008 is a result of such events taking place in Spain, which weighed in on the results for the EU. In 2009 the number of accidents drastically fell which may be explained by introducing of effective control procedures. Note the specific nature of air transport system in which during a single incident a much larger number of people may be killed than in the remaining transport systems.

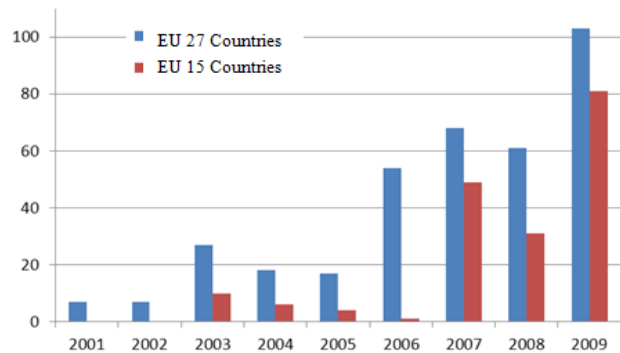

Fig. 2. Number of people killed in air accidents in the EU

Evaluation of the number of accidents in rail transport (fig. 3) shows that in the more developed countries accidents occur much less often. It is worth noticing that each year the number of people killed in both rail and road accidents in the EU decreases (figs. 3 and 4).

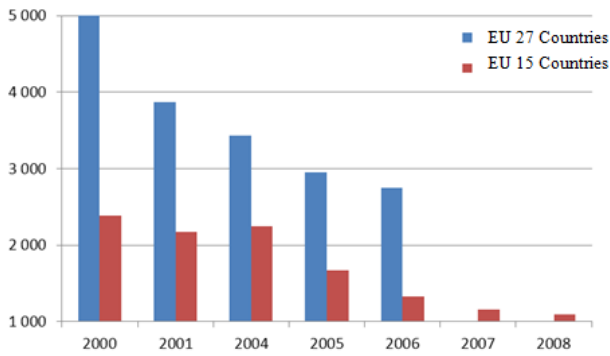

Fig. 3 Number of rail accidents in the EU

It is significant that the number of incidents in rail transport decreases each year. Figure 3 shows that this number fell from 5000 accidents in 2000 to 2800 in 2006. Unfortunately, there are no current data for the current list of the European Union member countries. Analyzing the situation of the “old 15” one may conclude that the number of accidents in rail transport was decreased by 55%.

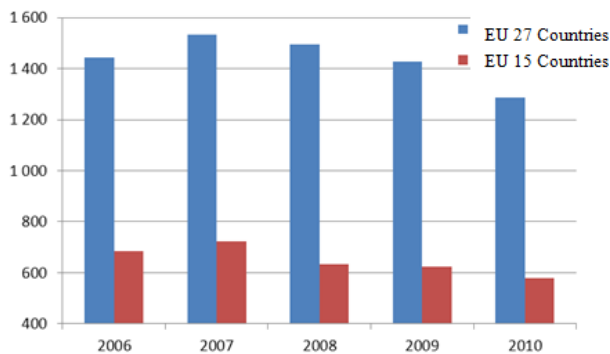

Figure 4 Number of people killed in rail accidents in the EU

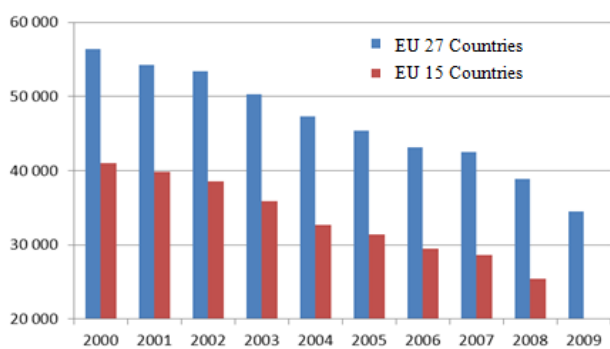

Figure 5 Number of people killed in road accidents in the EU

The presented analysis fails to fully reflect the factual state of safety of the carried out transport process. In order to achieve it, one would have to perform an analysis of the transport carried out in individual countries and create an evaluation model the results of which will supply information to help define crucial factors decisively interacting as to the level of safety of the carried out transport process.

Determining these factors as well as the evaluation of causes and effects of their influence serves as the basis for undertaking control operations of the level of system safety. The state of safety of the carried out transport was presented through the example of road transport – fig. 6. As the picture shows, the level of safety of the carried out transport is the lowest in Bulgaria and Poland, where the number of people killed per hundred accidents is higher than 10. This means that in every tenth accident one person is killed. Therefore, efforts must be undertaken in order to improve the safety level. Such efforts should include: identifying of the factors forcing the changes in the carried out process as well as creation of the model of evaluation of transportation process.

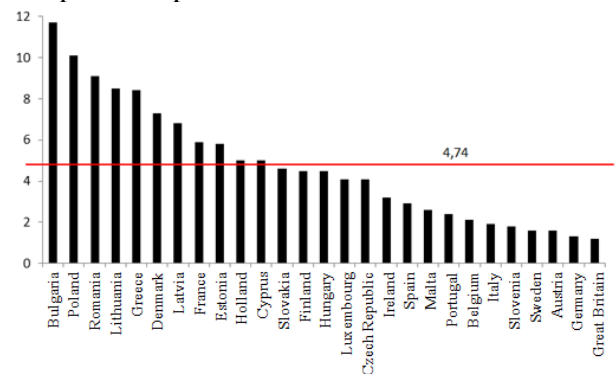

Fig. 6 Number of people killed per 100 accidents in the EU in 2010

Taking into consideration the average number of accidents occurring in individual transport systems, it is clear that 92% of them take place in road transport, around 7% in rail transport and only 1% in air transport. These results are presented in a graphic form in figure 7.

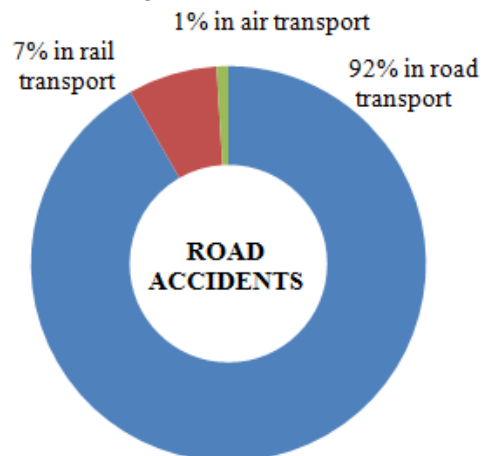

Fig. 7 Percentage of accidents in different transport systems

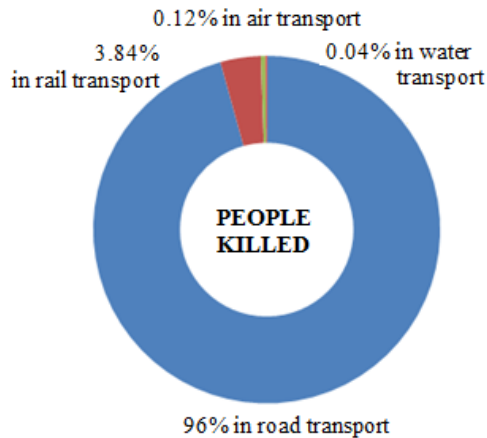

Fig. 8 Percentage of people killed in accidents occurring in different transport systems

4 The concept of the evaluation method for safety of transport system operation

On the basis of the analysis of the presented data as well as own research it was assumed that the influence of forcing factors are random phenomena and may occur individually or jointly. *Changes in the states of the forcing factors cause changes in the level of system operation safety, which, in effect, leads to changes in safety of the carried out transport process. Therefore, the evaluation of the state of system safety should be performed on the basis of the evaluation of the completed transport process taking into consideration the reactions between man, environment and technological object.* The above assumptions as to the suggested method of the evaluation transport system were presented in fig. 9.

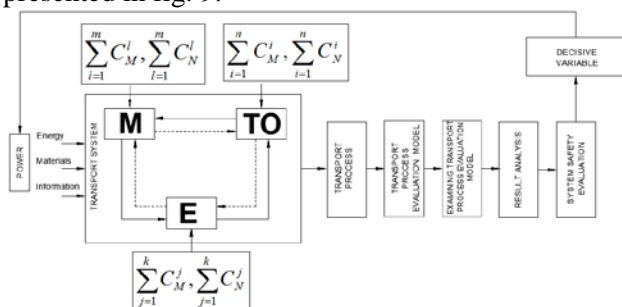

Fig. 9. Safety evaluation method of completed transport process.

The figure presents a graphic interpretation of the method of safety evaluation for completed transport process by any transport system. Such systems are social engineering systems, the basic elements of which are people <M> and means of transport <TO>, remaining in defined relations allowing for the realization of the functioning of the

system in the environment <E>, diversified depending on the type of the analyzed system. Each transport system, in order to carry out the transport task, must be powered by energy, materials and information. This powering makes it possible for the transport system to complete the transport process which may be evaluated from the point of view of a chosen aspect. However, the most important aspect of the process carried out by the transport system is its safety. Therefore, *in order to evaluate the system from this point of view one should determine a set of undesired events (accidents, collisions and threats), create a transport process evaluation model, carry out examination of the model taking into consideration their causes and effects, perform an analysis of the results of the examination of the model and set up decisive variables necessary to control the level of safety of transport system operation.* By examining the process carried out by the system, the decision maker is able to evaluate the significance of the event, its cause and effect, as well as undertake rational managing decision. The article presented an innovative method of the evaluation of the safety of transport system operation on the basis of the evaluation of undesired events occurring in the completed transport process. The method of the building of the method of the evaluation of transport process safety from the preferred view point was presented in the following article published in this magazine.

References:

- [1] Bojar P., Woropay M., Zurek J.: *Analysis of Operation Threat States of Selected Anthropotechnical Systems*. Proceedings Of The International Conference On Risk Analysis – ICRA4, Cyprus 2011
- [2] Bojar P.: *Analiza zawodności bezpieczeństwa wybranego obiektu technicznego*. Czasopismo Techniczne Mechanika Z 3-M/2005. WPK Kraków 2005
- [3] Borgoń J., Jaźwiński J., Klimaszewski S., Żmudziński Z., Żurek J.: *Symulacyjne metody badania bezpieczeństwa lotów*. Wydawnictwo naukowe ASKON Warszawa 1998
- [4] European database Internet site – www.epp.eurostat.ec.europa.eu
- [5] Mały Rocznik Statystyczny Polski 2011, Zakład Wydawnictw Statystycznych Warszawa 2011
- [6] Woropay M., Bojar P.: *Influence of Human Factor on Transport System Safety*. Scientific Journals Maritime University of Szczecin 27(99) z.2, Szczecin 2011