

Modeling and Simulation of Coal Winning Process on the Mechanized Face

Sorin Mihai RADU, Gabriel DOLEA, Razvan CRETAN

University of Petroșani, ROMANIA

sorin_mihai_radu@yahoo.com

Abstract: The modeling of the mechanized face is carried out by appealing to the flexible economic-mathematics models, to the advantages offered by their using. The concept of vague sets (by fuzzyfication) was used, the issues to be solved become more flexible and allow those who have to take a decision to get many variants for the objectively established functions among them can select the best variant, in accordance with the requirements of the moment and intuition.

Key words: mechanized face, system, optimization, correlation, model, simulation.

1 Introduction

Within the classical method, the model of the technological face variant selection for a set of concrete layer conditions and the optimization of the face parameters, too rely on the selecting and comparison of a low number of variants preliminary described.

But the high number of the equipment types and dimensions, such as: face mechanized support, face shearers and conveyers with the same technical parameters, allow the connection in a high number of machine complexes and their use for a certain set of given conditions that describe a coal layer.

Through a systemic approach, the issue of face technology and their parameters optimization can be enunciated as follows: “Found such a set of technological elements of the coal mining in the longwall faces and such a length of working face that, at the maximum admissible firedamp emission level for production ensure an extreme value (possibly maximum) for a selected criterion of optimization.”

2 The Model Of The Coal Winning Process On The Mechanized Face

The model will not exclude, on any subjective reason, any type of equipments that could be used in a certain condition range. That is the reason why the possible combinations of applicable equipments are in a high number, sometimes in a very high number.

The model of the mechanized face in the present paper is carried out by appealing to the flexible economic-mathematics models, to the advantages offered by their using.

The “mechanized face” system will work in certain geologic-mining conditions. However, the analyze of these conditions is not limited to the establishing some concrete values for identified factors of influence, because this values would correspond only for a certain face field and in a certain position of the face line on the surface of this field. Moreover, even in the framework of the same face field, the factors of influence can record variations.

Therefore, in the systemic approach of the issue of optimization for each factor described by a variable (which characterizes the geologic-mining conditions in which the “mechanized face” system will “work”) many values or many sub-fields should be foreseen according to the admissible variation for each variable.

For exemplification, the following factors of influence, described by the codified variables, will be taken into consideration, thus:

- 01- worked off layer thickness ;
- 02- layer slope ;
- 03- variation of the face level;
- 04- angle of raising/descending in the mining face advancing;
- 05- strength of the coal cutting;
- 06- coal hardness coefficient;
- 07- strength of the bottom compression;
- 08- strength of the roof compression.

A mechanized face will work in a certain period of time, in certain concrete conditions settled by a range of values of the above mentioned variables.

The design solutions (types of the face equipments for mechanization of the main operation complexes) that finally will define a mechanized face will have to be correlated with the geologic-mining conditions the mechanized face will work and that were previously described by the means of the stimuli-type variables.

The description of the technological solutions is made by a set of category -type checkable variables by which the type of the equipment used at every operation complex is defined. Each variable regarding the type of equipment will have as much qualitative values as different types of the respective equipment can be taken into consideration as being applicable in the given conditions.

For instance, we will note with A - the set of the face equipments, finite set.

$$A = \{a_1, a_2, \dots, a_j, \dots, a_k\} \quad (1)$$

$a_j, j = \overline{1, k}$ - is part of the A set and it is identified by the concrete type of equipment (respectively face shearer - in the given example).

3 The Use Of Fuzzy Function For The Compatibility Between Geo-Mining Condition And Mechanized Complex Equipments

In order to analyze the compatibility between the concrete geo-mining conditions in which the mechanized face and the equipment (face shearer) proposed to enter in the mechanized complex will work, that is, for short, for analyzing the conditions-solutions (C-S) compatibility it will be proceeded thus:

Be U- a certain set and A a finite subset of U, expressed as above.

A fuzzy subset F of U will be defined not only by its elements $a_j, j = \overline{1, k}$, but by the affiliation function, $\mu_F(a_j)$ of a_j F, too:

$$F = \{(a_1, \mu_F(a_1)), \dots, (a_j, \mu_F(a_j)), \dots, (a_k, \mu_F(a_k))\} \quad (2)$$

Symbolically, it is written

$$F = \sum_{j=1}^k (a_j, \mu_F(a_j)) \quad F = \int_A (a, \mu_F(a)), \quad (3)$$

in which the summing up and the integrals operations are obviously symbolic.

All the elements $a \in U$ for which $\mu_F(a) > 0$ constitutes the support of the F fuzzy set in U.

Elements for which $\mu_F(a) = 0.5$ marks the border between the elements that belong in an important extent to $U(\mu_F(a) > 0.5)$ and those belonging to a less important extent to $U(\mu_F(a) < 0.5)$ and are called crossing points of U.

The affiliation function $\mu_F(a)$ is defined on the U set and has values between the interval of [0,1].

$$\text{Thus: } \mu_F(a): U \rightarrow [0,1] \quad (4)$$

The way of defining of a F fuzzy set is called label.

Therefore, in the given example, we define the following labels $F_i, i = \overline{1, 8}$ -relative to those "i" stimuli variables that characterizes the geologic-mining conditions of the mechanized face:

F1-number of face shearers that can work off a coal layer having a thickness between I_1 and I_2 .

F2-number of the face shearers that can work off a coal layer with a slope at least equal with " α "-degrees.

F3-number of face shearers that can work off a coal layer that have a variation of the slope angle on the face line at least " β " degrees.

F4-number of the face shearers that can work off a coal layer having an angle of raising/decreasing in the line face advancement of " γ " degrees.

F5-number of the face shearers that can work off a coal layer with a strength of cutting at least of " A "[N/cm].

F6- number of the face shearers that can work off a coal layer having a coefficient of coal cutting at least of " Γ ".

F7-number of the face shearers that can work off a coal layer in a face having a strength of compression of the bottom of the most " P_c ".

F8-number of the face shearers that can work off a coal layer in a face having strength of compression of the roof at most " P_a ".

As a conclusion, the F_i labels are defined such as:

F1-is defined relatively at variable 01;

F2-is defined relatively at variable 02;

F3-is defined relatively at variable 03;

F4-is defined relatively at variable 04;

F5-is defined relatively at variable 05;

F6-is defined relatively at variable 06;

F7-is defined relatively at variable 07;

F8-is defined relatively at variable 08.

Thus, for the given example, the F fuzzy sets have the following form.

Obs. The summing up operation used in defining the F fuzzy functions - is symbolic:

$$\begin{aligned}
 F_1 &= (a_1, \mu_{11}) + (a_2, \mu_{12}) + \dots + (a_j, \mu_{1j}) + \dots + (a_k, \mu_{1k}) \\
 F_2 &= (a_1, \mu_{21}) + (a_2, \mu_{22}) + \dots + (a_j, \mu_{2j}) + \dots + (a_k, \mu_{2k}) \\
 F_{31} &= (a_1, \mu_{31}) + (a_2, \mu_{32}) + \dots + (a_j, \mu_{3j}) + \dots + (a_k, \mu_{3k}) \\
 F_4 &= (a_1, \mu_{41}) + (a_2, \mu_{42}) + \dots + (a_j, \mu_{4j}) + \dots + (a_k, \mu_{4k}) \\
 F_5 &= (a_1, \mu_{51}) + (a_2, \mu_{52}) + \dots + (a_j, \mu_{5j}) + \dots + (a_k, \mu_{5k}) \\
 F_6 &= (a_1, \mu_{61}) + (a_2, \mu_{62}) + \dots + (a_j, \mu_{6j}) + \dots + (a_k, \mu_{6k}) \\
 F_7 &= (a_1, \mu_{71}) + (a_2, \mu_{72}) + \dots + (a_j, \mu_{7j}) + \dots + (a_k, \mu_{7k}) \\
 F_8 &= (a_1, \mu_{81}) + (a_2, \mu_{82}) + \dots + (a_j, \mu_{8j}) + \dots + (a_k, \mu_{8k})
 \end{aligned}
 \tag{5}$$

where μ_{ij} with $i = \overline{1,8}$ (in the given example) and $j = \overline{1,k}$ -represents the $\mu_F(a_{jk})$ affiliation function of the a_j elements to F_i .

Once the $\mu_{Fi}(a_j)$ affiliation functions determined, a “matrix of affiliation” can be drawn up. This matrix is of the type of “conditions-solutions” (C-S) on concrete conditions and has on rows the F_i fuzzy functions that characterize the geologic-mining conditions in which will work the mechanized face, and on columns the a_j elements of the $A(j = \overline{1,k})$ sets and that symbolize the concrete type of checkable variables (in the given example the type of the face shearers) together with a complex of mechanized face are to be design.

Solutions	A					
Conditions	a_1	a_2	...	a_j	...	a_k
$(00) \bigcap_{i=1}^8 F_i$	$\min \mu_{i1}$	$\min \mu_{i2}$...	$\min \mu_{ij}$...	$\min \mu_{ik}$
F_1	$\min \mu_{11}$	$\min \mu_{12}$...	$\min \mu_{1j}$...	$\min \mu_{1k}$
F_2	$\min \mu_{21}$	$\min \mu_{22}$...	$\min \mu_{2j}$...	$\min \mu_{2k}$
F_3	$\min \mu_{31}$	$\min \mu_{32}$...	$\min \mu_{3j}$...	$\min \mu_{3k}$
F_4	$\min \mu_{41}$	$\min \mu_{42}$...	$\min \mu_{4j}$...	$\min \mu_{4k}$
F_5	$\min \mu_{51}$	$\min \mu_{52}$...	$\min \mu_{5j}$...	$\min \mu_{5k}$
F_6	$\min \mu_{61}$	$\min \mu_{62}$...	$\min \mu_{6j}$...	$\min \mu_{6k}$
F_7	$\min \mu_{71}$	$\min \mu_{72}$...	$\min \mu_{7j}$...	$\min \mu_{7k}$
F_8	$\min \mu_{81}$	$\min \mu_{82}$...	$\min \mu_{8j}$...	$\min \mu_{8k}$

Figure 1.

In the matrix, at F_i fuzzy function rows intersection with the column of a_j elements is registered the value of the affiliation function μ_{ij} or otherwise noted $\mu_{Fi}(a_j)$ that quantifies the affiliation degree of the a_j element to the F_i function. (extent in which the element $a_j \in A$ fulfills the F_i label; for example, the extent in which the 1K101 face shearer is able to cut a coal layer having a 1,4÷2,1m).

As a conclusion, the affiliation matrix (C-S) will look as presented in figure 1.

For each a_j element, that is for each “j” column it is established:

$$\min_{ij} = \min(\mu_{1j}, \mu_{2j}, \dots, \mu_{ij}, \dots, \mu_{8j})
 \tag{6}$$

This way is filled the (00) row, which will include the affiliation degrees of the “ $\bigcap_{i=1}^8 F_i$ ” label”.

After being known the F_i fuzzy functions the intersection fuzzy set F is determined:

$$F = \bigcap_{i=1}^8 F_i = (a_1, \min \mu_{i1}) + (a_2, \min \mu_{i2}) + \dots + (a_j, \min \mu_{ij}) + \dots
 \tag{7}$$

Obs. The intersection of two F and G sets is defined as:

$$F \cap G = \int_A (a, \min(\mu_F(a), \mu_G(a)))
 \tag{8}$$

one “a” element has the affiliation function at the intersection set $F \cap G$:

$$\mu_{F \cap G(a)} = \min(\mu_F(a), \mu_G(a))
 \tag{9}$$

The high of the fuzzy set F is defined as: $h_F = \max \mu_F(a)$.

Being specified these elements, the following statement can be done:

The element with the highest affiliation function in F is a_j for that $\min \mu_{ij}$ has the maximum value (the a_j element for which on the (00) row is the maximum value).

Therefore, the element with the highest affiliation function in $F = \bigcap_{i=1}^8 F_i$ is that corresponding to the

height of a $\bigcap_{i=1}^8 F_i$ fuzzy function:

$$h_{\bigcap_{i=1}^8 F_i} = \max \left(\min \mu_{\bigcap_{i=1}^8 F_i} (a) \right) \tag{10}$$

So we can establish which is the a_j element (the equipment that could “enter” in the mechanized face complex) which will meet the best the needs of the concrete geologic-mining conditions (and in which will work the future mechanized face) defined by stimuli variables and for that those F_i fuzzy functions were built. Analogously, it can be

analyzed the opportunity of using the other equipment types (for example B-mechanized supporting; C-face conveyors) with that the face shearer could work in the mechanized complex in the same concrete geologic-mining conditions.

Obs. It will be taken into consideration (discussion) all the elements $a \in A, b \in B, c \in C$, for which $\mu_{nF}(a) > 0.5, \mu_{nF}(b) > 0.5, \mu_{nF}(c) > 0.5$, considering that the elements for that $\mu_{nF} > 5$, belong in an important extent to F, unlike those for that $\mu_{nF}(a) < 5$; which are considered to belong in a less important extent to F. After drawing up all the “C-S” affiliation matrixes (for all the type of equipments which are eligible for setting up together an equipment complex), are analyzed the compatibility between every equipment belonging to the above mentioned equipments range in order to set up the mechanized face complexes able to work in concrete geologic-mining conditions.

For this it is appealing to the compatibility matrix (S-S) on concrete given conditions.

The fuzzyficated compatibility “solutions-solutions” (S-S) matrix for the concrete conditions (fig.2)

Machine	Type	Sub-set	Element	Affilia-tion degree	09			10			11		
					01	02	03	01	02	03	01	02	03
Shearer	1K10 1 . . .	09	01	μ_{01}^{09}				1		1	1		
			02	μ_{02}^{09}				1			1	1	
			03	μ_{03}^{09}			1						
Mecha-nized roof supports	10	01	μ_{01}^{10}						1		1	
			02	μ_{02}^{10}							1		
			03	μ_{03}^{10}						1			
Con-veyor	11	01	μ_{01}^{11}									
			02	μ_{02}^{11}									
			03	μ_{03}^{11}									

Figure 2.

The fuzzyficated “solutions-solutions” (S-S) compatibility matrix for the concrete conditions

includes the figure “1” that certifies the compatibility between the “row” and “column”

element and, respectively the figure “0” (or it can be omitted) which codes the incompatibility between the “row” and “column” elements being taken into consideration. Also, the compatibility (S-S) matrix includes an extra column given the classical compatibility (S-S) matrix, named column of affiliation degree. The numerical values of this column quantifies the affiliation degree of each element of the solutions sub-sets (for each

equipment belonging to the types of equipments eligible for setting up a mechanized complex) for the concrete geological-mining conditions, conditions defined by the elements belonging to the “conditions” sub-sets. Therefore, due to this matrix, the compatibility between different types of equipments that can enter in the mechanized face complex can be analyzed.

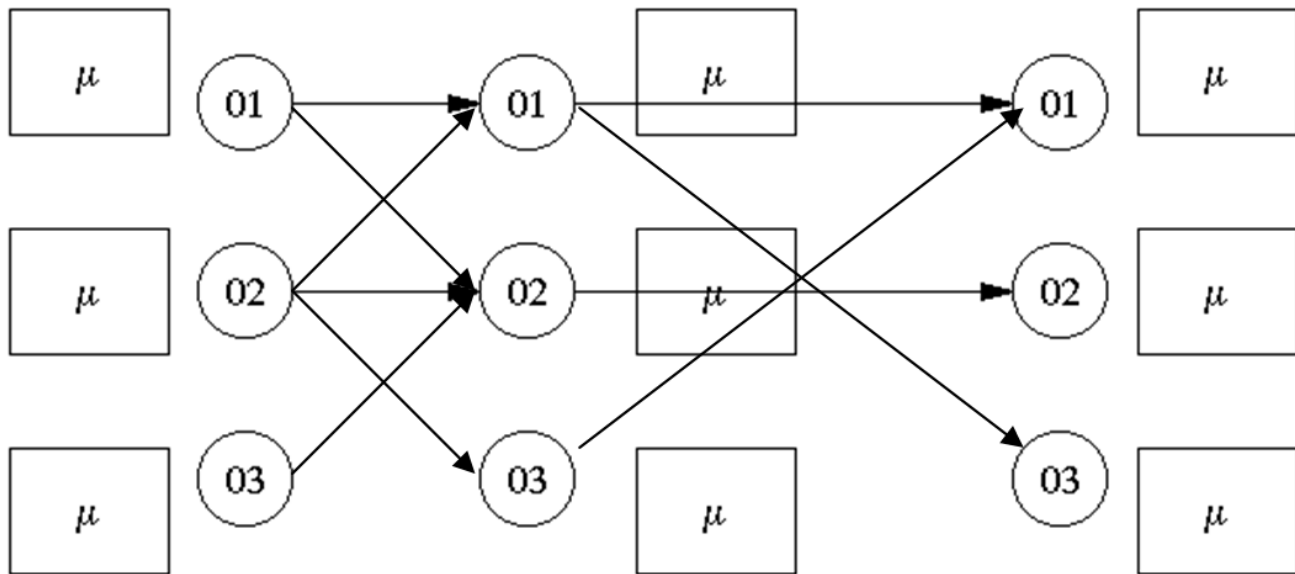

Figure 3.

This matrix includes all the applicable variants. The possible applicable variants can be identified due to the fuzzyficated compatibility “S-S” matrix, or by hand proceedings using the successions graph (drew up by the means of modules from the diagonal), or by computer programmed algorithms.

The succession graph will have a special aspect, every element of the graph (every joint) will have attached a joint constant, named affiliation constant, which will define the compatibility of the respective type of equipment with concrete deposit conditions in which the issue of designing of the mechanized face complex is analyzed.

For the given situation (a hypothetical example) the succession graph will be as in figure 3.

4 Conclusions

In the next analyze stage; the variants generated by the “S-S” matrix will have to be assessed. The assessment of the variants will be made in the accordance with the type of functions that have to

be assessed by the ways of succession graph (for example the price of the tone per face).

Therefore, at the end a series of technological variants have resulted, their assessment in order to need the criterion of proposed optimization will have to take into account this array of affiliation degree. So, by applying the concept of vague sets (by fuzzyfication), the issues to be solved become more flexible and allow those who have to take a decision to get many variants for the objectively established functions among them can select the best variant, in accordance with the requirements of the moment and intuition.

References:

- [1] DOLEA, G - *Researches Regarding the Systemic Design in Order to Optimize the Mechanized Varieties of the Longwall Faces in the Jiu Valley Mining Coal Basin*- Doctoral Thesis - University of Petrosani, 2000

[2] ILIAȘ ,N., ZAMFIR V. RADU S. and others – *Mining Machines – Calculus examples*, Technical Publishing House, Bucharest, 1993

[3] IONICA, A.; LEBA, M.; EDELHAUSER, E., *Quality Evaluation Of The Human Action Performing In A Working System Using Fuzzy Logic*, International Conference of Modelling and

Simulation in Engineering, Economics and Management, Barcelona, Spain, 2010, Pages: 145-152, DOI: 10.1142/9789814324441_0019

[4] STOICA, M., IONIȚĂ I., BOTEZATU, M. - *Economic Processes Modelling and Simulation*, Economic Publishing House, Bucharest, 1997.