

# Microcontroller based closed-loop automatic speed control of DC motor using PWM

I. MOAZZEM, S. RAHMAN, M A MATIN

Dept. of Electrical Engineering and Computer Science, North South University  
Dhaka, Bangladesh

**Abstract**-The electric drive systems used in many industrial applications require higher performance, reliability, variable speed due to its ease of controllability. The speed control of DC motor is very crucial in applications where precision and protection are of essence. Purpose of a motor speed controller is to take a signal representing the required speed and to drive a motor at that speed. Microcontrollers can provide easy control of DC motor. Microcontroller based speed control system consist of electronic component, microcontroller and the LCD. In this paper, implementation of the ATmega8L microcontroller for speed control of DC motor fed by a DC chopper has been investigated. The chopper is driven by a high frequency PWM signal. Controlling the PWM duty cycle is equivalent to controlling the motor terminal voltage, which in turn adjusts directly the motor speed. This work is a practical one and high feasibility according to economic point of view and accuracy. In this work, development of hardware and software of the close loop dc motor speed control system have been explained and illustrated. The desired objective is to achieve a system with the constant speed at any load condition. That means motor will run at a fixed speed instead of varying with amount of load.

**Keywords**- DC motor, Speed control, Microcontroller, ATmega8, PWM.

## 1. Introduction

Speed control of dc motor could be achieved using mechanical or electrical techniques. In the past, speed controls of dc drives are mostly mechanical and requiring large size hardware to implement. The development has launched these drives back to a position of formidable relevance, which were hitherto predicted to give way to ac drives. Some important applications are: rolling mills, paper mills mine winders, hoists, machine tools, traction, printing presses, textile mills, excavators and cranes. Fractional horsepower dc drives are widely employed -as servo means for positioning and tracking [1]. Controlled rectifiers provide a variable dc voltage from a fixed dc voltage. Due to their ability to supply a continuously variable dc voltage, controlled rectifier and dc choppers made a revolution in modern industrial equipment and variable-speed drives [2].

Adjustable speed drives may be operated over a wide range by controlling armature or field excitation. Transistor and thyristor along with various analog digital chips used in firing or controlling circuits have made dc drives more accessible for control in innumerable areas of applications [3]. Recent developments in the area of semiconductor technology have made smaller, faster microprocessors and microcontrollers available at reduced cost. [4] .The potential use of microprocessors to control some or all electronic functions justifies their use.

The main objective of this work is to become familiar with the design and implementation of both

software and hardware of a microcontroller based closed loop speed control of DC motor and to give senses of occurring overload condition to the operator at overload condition. The purpose of a motor speed controller is to take a signal representing the required speed, and to drive a motor at that speed.

## 2. Related works

A reasonable number of works have found in the literature, regarding the employment of solid-state devices for the control of dc drives. The paper of Kurnera, Dayananda and Jayawikrama, elucidated the use of chopper in collaboration to PC for the control of dc motor speed. Software was developed, fed into a PC and consequently, commands were given to the chopper via the computer for control of motor speed[3].The use of standalone micro controller for the speed control of DC motor is past gaining ground. Nicolai and Castgnet have shown in their paper how a microcontroller can be used for speed control. The operation of the system can be summarized as: the drive form rectified voltage; it consists of chopper driven by a PWM signal generated from a microcontroller unit (MCU). The motor voltage control is achieved by measuring the rectified mains voltage with the analog to-digital converter present other micro controller and adjusting the PWM signal duty cycle accordingly [5].

Another system that uses a microprocessor is reported in the work of khoel and Hadidi a brief description of the system is as follows: The microprocessors computes the actual speed of the motor by sensing the

terminal voltage and the current, it then compares the actual speed of the motor with the reference speed and generates a suitable signal control signal which is fed into the triggering unit. This unit drives an H-bridge Power MOSFET amplifier, which in turn supplies a PWM voltage to the DC motor [6].

In this paper, a dc motor with fixed speed control system is presented, which has high precision, reliability and adaptability for different motor ratings with good speed response.

### 3. Methodology

A scheme that address on building up such a system as described above is presented in here. As the system is based on the speed controlling of a DC motor, so the desired goal is to achieve a system with constant speed at any load condition. That means motor will run at fixed speed at any load condition. It will not vary with the amount of load. The software is made in such a way that even an unskilled operator can operate it. This system describes the design and implementation of the microcontroller based closed loop DC motor speed controller that controls the speed of a DC motor by using PWM and DC chopper. In implementing this work frequency independent PWM output with variable duty cycle that can vary from 0% to 100% is generated. Furthermore an LCD display was fabricated to display the output; this kind of setup provides a complete user interface unit. Hence the system is complete stand-alone and user friendly.

In case of sudden load drops the speed of the motor will be very high. As a result output voltage will be also very high. So controller unit will sense output voltage and will compare with the desired level of voltage.

In case of excessive load, motor cannot run at its desired speed, and then OCR will start increasing until reaches its maximum value. After reaching the maximum value, there remains no improvement of the speed, i.e. output voltage does not matches the desired level then microcontroller will send a message "OVERLOAD" using the LCD, so that the user can understand the condition and hence reduce the load of the motor.

### 4. System overview

The motor to be controlled is fed by a DC source through a chopper. The techogenerator senses the speed, which gives voltage as output. And this voltage is fed to the microcontroller to drive the speed of the motor.

The output voltage of techogenerator is provided to the microcontroller and microcontroller determines the output voltage of the chopper fed to the DC motor for desired speed.

### 5. Circuit description

1. The circuit is based on PWM technique. ATmega-8's timer portion has this special feature. By adjusting register values (ocr, tccr etc) duty cycles can be controlled.

2. When motor run at 70% of duty cycle, the techogenerator gives a Voltage corresponds to that speed. Now if any load occurs, desired speed will be decreased. Hence the voltage drop will be less. This voltage is fed into the ADC of microcontroller. By comparing the previous value microcontroller can sense the decrease in the speed

3. After sensing the load condition it will start increasing its duty cycle until it reaches the desired speed.

4. During overload condition Microcontroller will try to reach the desired speed by increasing duty cycle. But if at the maximum duty cycle it fails to run it will show a message to the user through A LCD panel. The message indicates OVERLOAD. Now user can run the machine again at desired speed by decreasing the load.

### 6. Pulse width modulation (PWM)

PWM is a very efficient way of providing intermediate amounts of electrical power between fully on and fully off. A simple power switch with a typical power source provides full power only, when switched on. PWM is a comparatively-recent technique, made practical by modern electronic power switches.

The microcontroller, ATmega8 has 3 timer/counter. Among them timer/counter 1 and 2 are featured with PWM. We have used timer/counter2 (8-bit) to generate PWM for varying the speed of DC motor. We used Phase correct mode here. Again it has 2 different mode of operation-inverted and non-inverted mode. Non-inverted mode is used here.

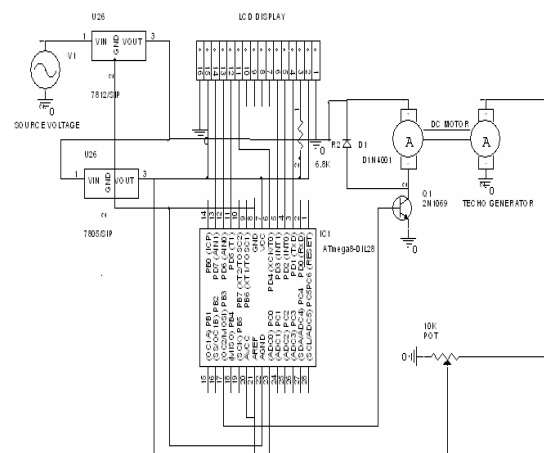

Fig. 1 Motor Controller Sections

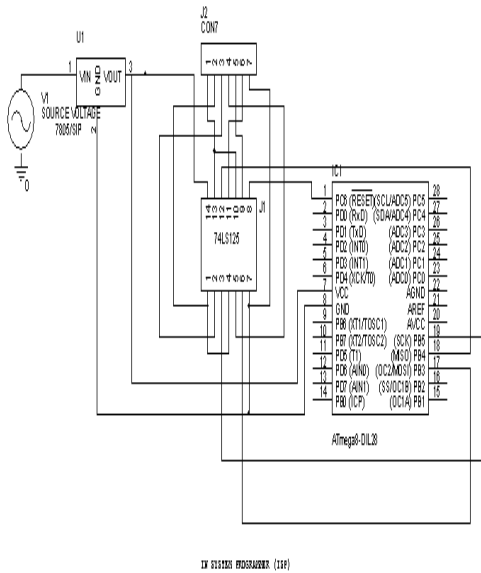

Fig.2 In System Programmer

**7. Sensor design**

Another motor is used for speed sensing purpose is called the tachogenerator. For a DC motor voltage is directly proportional to the speed. The tachogenerator is coupled with the motor and a potentiometer is connected to the terminal of the tachogenerator. Tachogenerator gives voltage drop across the potentiometer according to the speed of the motor. If the motor runs at a low speed it gives a lower value. When it runs at its maximum speed, it gives a larger amount of voltage.

**8. ADC devices**

ADC has n-bit resolution where n can be 8,10,12,16 or even 24 bits. The higher resolution ADC provides a smaller step size, where step size is the smallest change that can be discerned by an ADC. AT -Mega-8 has one 10 bit Successive Approximation Register type ADC with 6 multiplexed channels.

**9. Results & discussion**

The results obtained are as expected which can be discussed as follows.

**9.1 Chopper circuit output**

A pulse with fixed frequency is generated by the microcontroller, which is fed to the base of transistor. Transistor acts here as a switch. The output voltage of the motor is dependent on the amount of the on time of the transistor. The more time transistor remain on more the voltage will produce. A Freewheeling diode is used for back e.m.f. protection given to other portion.

Motor terminal voltage at various duty cycles:

D (Duty cycle)	Voltage using equation(V)	Voltage measured by multimeter(V)
.1	1.2	3
.3	3.6	5.3
.5	6	7.8
.7	8.4	10
.9	10.8	11.6
1	12	11.6

**9.2. Sensor output**

Output voltages at different duty cycles has found by varying the duty cycle controller register OCR (output compare register) shown in Fig.3. The system shows the immediate response of maximum output voltage when 100% duty cycle is achieved.

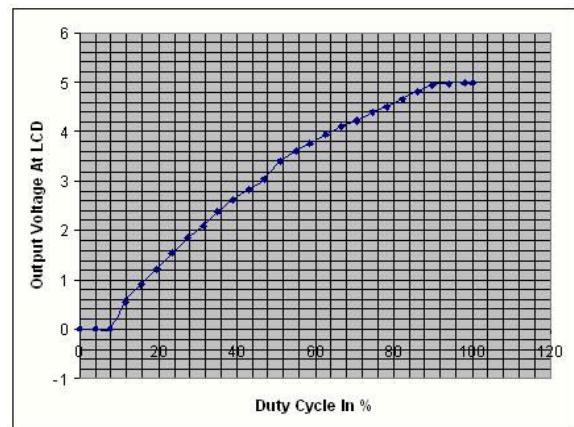

Fig3: Duty cycle vs. Output voltage

The voltage drop across the potentiometer fed to ADC of the microcontroller. According to the ADC value, microcontroller will take decision whether pulse width needs increment or decrement.

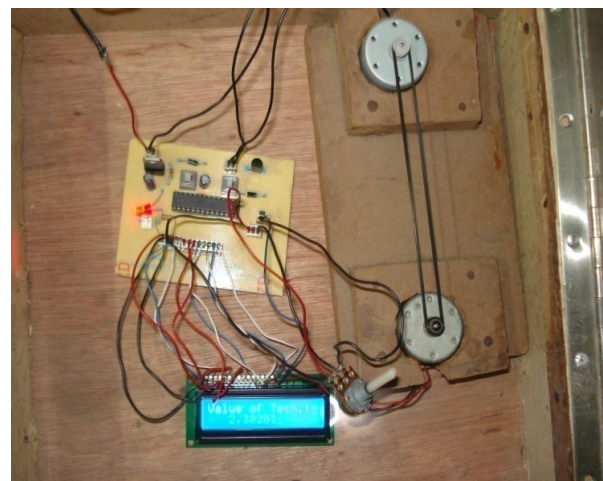

Fig. 4 Circuit diagram

## 10. Conclusion

The microcontroller based closed-loop automatic speed control of dc motor has been introduced. Controlling a permanent magnet DC motor with speed feedback through a techogenerator will implemented using an ATmega8L microcontroller. The system will be made user friendly so that anybody can operate the system without any trouble. LCD display will used to show the condition of the system. Knowing the condition the user can change the amount of load if necessary.

## REFERENCES

- [1] Gopal K. Dubey, "Fundamentals of Electric Drives", Narosa Publishing House New Delhi, 1989.
- [2] Muhammad H. Rashid, "Power Electronics Circuits, Devices, and Applications," Prentice Hall, 3<sup>rd</sup> edition, 2003.
- [3] Kumara MKSC, Dayananda PRD, Gunatillaka MDPR, Jayawickrama SS, "PC based speed controlling of a dc motor", A final year report University of Moratuwa Illiniaus USA, 2001102.
- [4] J Nicolai and T Castagnet, "A Flexible Micro controller Based Chopper Driving a Permanent Magnet DC Motor", The European Power Electronics Application. 1993.
- [5] J. Chiasson, Nonlinear Differential-Geometric Techniques for Control of a Series DC Motor, *IEEE Transaction on Control Systems Technology*. vol 2, pp. 35-42, 1994.
- [6] A Khoei Kh. Hadidi, "MicroProcessor Based Closed-Loop Speed Control System for DC Motor Using Power MOSFET", 3<sup>rd</sup> IEEE international conference on Electronics, Circuits and Systems (1996) vol.2, pp.1247-1250.
- [7] Peter Spasov, "Microcontroller Technology: The 68HC11" Prentice Hall, 5<sup>th</sup> edition, 2004.
- [8] In System Programming (ISP) for ATMEL chips, <http://www.ikalogic.com/isp.php>.
- [9] Pulse width modulator module (PWMM), ATmega8L data sheet.
- [10] ADC devices, ATmega8L data sheet.
- [11] LCD interfacing, the microcontroller and embedded systems by Muhammad Ali Mazidi, Janice Gillispie Mazidi, Rolin D. Mckinlay.
- [12] LCD interfacing with Microcontrollers Tutorial Index, <http://www.8051projects.net/lcd-Interfacing/>