

Solar Photovoltaic Panels Tracking System

AHMED ABU HANIEH
 Mechanical Engineering Department
 Birzeit University
 P.O Box 14 - Birzeit
 PALESTINE

ahanieh@birzeit.edu <http://www.birzeit.edu>

Abstract: - This research project concentrates on the design and control of a two-degrees-of-freedom orientation system for the photovoltaic solar panels in sunny regions which are considered very rich in solar energy. A brief background on the sun path and behavior at Latitude 31° as an example is discussed to help in the calculations of the needed angle ranges. The orientation system calculations are based on astronomical data and the system is assumed to be valid for any region with small modifications. The system is designed to control the Altitude angle in the vertical plane as well as the Azimuth angle in the horizontal plane of the photovoltaic panel workspace. The mechanical design is a simplified one using rotary joints and DC motors. This orientation system is expected to save more than 40% of the total energy of the panels by keeping the panel's face perpendicular to the sun. This percentage is assumed to be lost energy in the fixed panels. The dynamics of the panel behave like a low-pass filter which facilitates the job of the controller that behaves as a good vibration isolator passing the orientation torques at low frequency and attenuating the high frequency disturbance signals coming from the surrounding environment. Point to point open-loop control is proposed in this mechanism to ensure intermittent motion when tracking the sun. To solve the problem of cloudy days, closed-loop control can be added to the system by using solar tracking sensors and feedback control loops. A special care should be taken to the design of the grid arrangement of panels in the collecting plant. The distance between two panels has to be twice the dimension of the panel to avoid the problem of shadow when the sun is inclined not only in the morning but also in the afternoon hours. A specific architecture and arrangement of panels in the collecting grid is proposed at the end of the document.

Key-Words: - Solar Photovoltaic Panels, Orientation, Solar Tracking, Open-loop Control, Closed-loop control, Sensor, Azimuth, Altitude.

1 Introduction

The world population is increasing every day and the demand for energy is increasing accordingly. Oil, as the main source of energy nowadays, is expected to end up from the world during the recent century which explores a serious problem in providing the humanity with an affordable and reliable source of energy. This proves the high need for renewable energy resources with cheap running costs. Solar energy is considered as one of the main energy resources in warm countries. In general, the Middle East region has a relatively long sunny day for more than ten months and partly cloudy sky for most of the days of the rest two months. This makes these countries, especially the desert sides in the south, very rich in solar energy. Many projects have been done on using photovoltaic cells in collecting solar radiation and converting it into electrical energy but most of these projects did not take into account the difference of the sun angle of incidence by installing the panels in a fixed orientation which influences very highly the solar energy collected by the panel. Fig. 1 shows a curve for the relationship between the solar radiation and the solar angle of incidence [1].

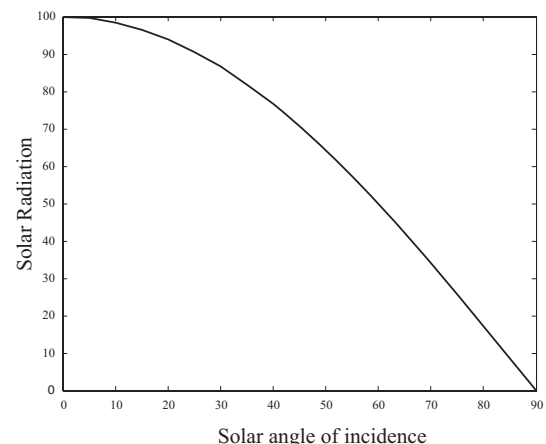

Fig. 1. Rate of change of solar radiation as a function of the sun angle of incidence

As far as it is not our choice that the sun rays are inclined at the surface of the panel, it should be taken into account that the angle of inclination ranges between -90° after sun rise and $+90^\circ$ before sun set passing with 0° at noon. This makes the collected solar radiation to be 0% at sun rise and sun set and 100% at noon. This variation of collection leads the photovoltaic panel to lose more than 40% of the collected energy.

Fig. 2 shows the sun path at the latitude of 31° [1]. From this figure, one can estimate the exact position of sun in every month and at any time during the day. The position is decided by two angles in spherical coordinates; the Altitude angle which is the angle of the sun in the vertical plane in which the sun lies, and the Azimuth angle which represents the angle of the projected position of the sun in the horizontal plane. These two angles will be discussed deeply later in this document.

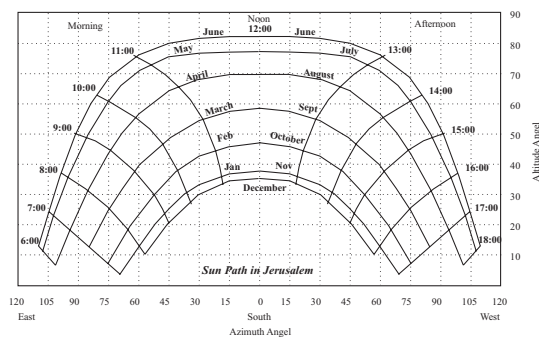

Fig. 2. Sun path at Latitude 31° [1]

Several working groups have worked previously on the problem of sun tracking to increase the energy efficiency. Nicolas and CEM have designed a single angle tracking solar cooker that consists of two rotating reflection mirrors that can rotate to track the azimuth angle of the sun but the oven is fixed with respect to the Altitude angle [2]. Kohler et al. in [3] discussed a comparison between the fixed installation and solar tracking installation of photovoltaic panels for greened roofs. Authors offer here three tracking systems: the first system is called EGIS tracking system that rotates horizontally by 180° and vertically by 65° using tilting rotors. The second system is called ALTEC system that rotates around a tilted North-South oriented axis with horizontal range of 54° East to 54° West and the mounting angle is set to 30° . This system uses thermohydraulic or gravity tracking method by using a liquid with low boiling point confined in two connected tanks. Finally, the third system is TRAXLE tracking system, this system needs electricity to drive the DC motor used for rotation which takes about 1% of the panel's surface. Panels in this system rotate by 120° .

Peterson et al. in [4] have designed a two-axis solar tracker with stepper motors for the azimuth and Altitude rotational degrees of freedom. Relay circuits have been used for the control purpose. Whittaker et al. in [5] discuss a new design of a solar powered polar rover which is a prototype robot called Hyperion. Hyperion means "The sun follower" in Greek language. In [6], Bong Wie Discusses a dynamic model and control design for a 76×76 m square sail employing spin stabilization, reaction wheel, a two-axis gimbaled control boom and a sail panel translation and rotation system. The US Patent of Murphy and Crowley in [7] discusses an optimal solar tracking system for a spacecraft to compensate for the undesired disturbances using a time modulated solar tracking scheme which increases the power efficiency without influencing the transmitted torque. Khan and Ali in [8] discuss an automatic sun tracking system with six functional sensors, stepper motors and microcontroller control system for automatic orientation of the solar panel towards the sun. The microcontroller stops all operations at night and repositions the panel towards east to be ready for the next morning.

This document discusses a new design for two-axis solar panel tracking system. The mechanical design of the system will be discussed and illustrated in the next section. Kinematic analysis and calculations depending on the astronomic relations will be discussed and simulated. Dynamics and control techniques of the system will be explained showing the dynamic model and state space approach. Moreover, this document will discuss the design of the general grid installation and best arrangement to reduce the shadow effect. Results and conclusions will be discussed at the end of the document.

2 Tracker design

Fig. 3 depicts an experimental setup of a squared solar panel with two degrees of freedom. The panel is symmetric with a total mass of 15 kg including the frame. Two DC motors are used to drive the two rotational degrees of freedom. The motors are mounted directly on the rotation pins of the rotational joints to reduce losses caused by linkages and joints and to avoid using more linkages and mechanisms.

3 Kinematics

The maximum expected insolation of the sun is 1000 W/m^2 . Assuming a 10% total efficiency of the photovoltaic panels, the predicted output power from the panel will be 100 Watt. Although, it is known that there are panels with higher efficiency but it is preferable to calculate for the least case. The rotational speed of the earth around its axis of rotation, which can be imagined

relatively as the speed of the sun around the earth, is 15° / hour or 0.25° / min. But the system is designed to move discretely to cover the total daily track in 10 steps to reduce the operating time. After sunset, the panel is designed to return back pointing towards the east to collect the sun radiation next morning. This return process can be done in 30 seconds or a frequency of 0.07 Hz. The total mass of the panel with the frame is 15 kg acting at a distance ($d = 0.1$ m) from the center of the joint as shown in Fig. 4. This leads to the maximum needed torque to rotate the panel which is equal to 15 N.m while the maximum needed power is 1 Watt which forms 1% of the output of the panel. This calculation shows that it is feasible to rotate the panel using electric motors fed by the output of the panel itself. The previous calculation is based on having a symmetric shape of the panel neglecting the friction of the rotational joint and the air drag force.



Fig.3. Birzeit Setup of solar tracker

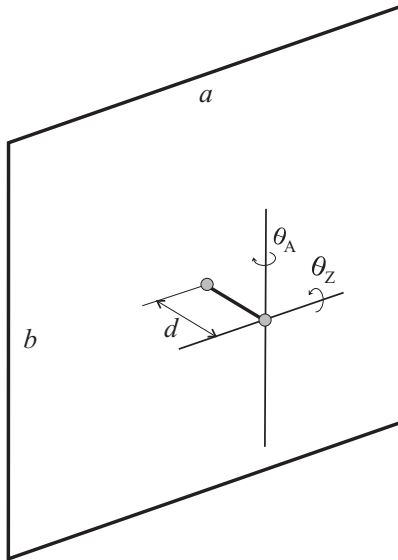

Fig. 4. Schematic diagram showing the orientation parameters

Fig. 5 shows a typical behavior for the sun path in December (winter) and June (summer). The rotational angle of the orientation system in the vertical plane (θ_z) can be calculated from the following equation [9]:

$$\sin \theta_z = \sin \phi \cdot \sin \delta + \cos \phi \cdot \cos \delta \cdot \cos \omega$$

Where:

θ_z is the Altitude angle of the system ($\theta_z = 90^\circ - \text{zenith angle of the sun}$)

ϕ is the Latitude ($\phi = 31.0^\circ$ for our example)

ω is the hour angle (15° / hour), where $\omega = 0$ at local noon.

δ is the solar declination, where δ is calculated from Cooper's equation,

$$\delta = 23.45 \cdot \sin \cdot \left[\frac{360}{365} (284 + N) \right]$$

Here, N is the day of the year (1 - 365), $N = 1$ on the 1st of January.

The rotational angle of the system in the horizontal plane (θ_A) is calculated from the equation [10], [11]:

$$\sin \theta_A = \frac{\cos \delta \cdot \sin \omega}{\cos \theta_z}$$

Where:

θ_A is the Azimuth angle of the system

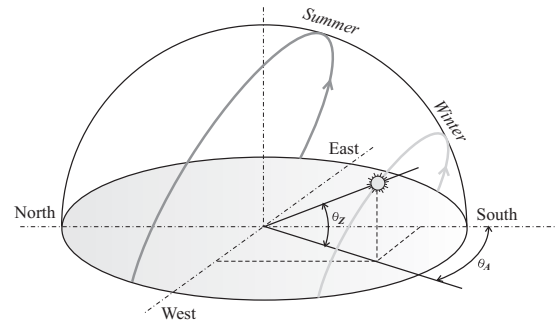

Fig. 5. Typical behavior for the sun path

3 Simulation

The real sun path of at Latitude of 31.0° has been simulated using MATLAB software. The simulation has been taken for the different months of the year. Fig. 6 shows a three dimensional plot for this simulation.

The results have been shown from June to December because the simulation of May is close to that of July, simulation of April is close to August and etc ...

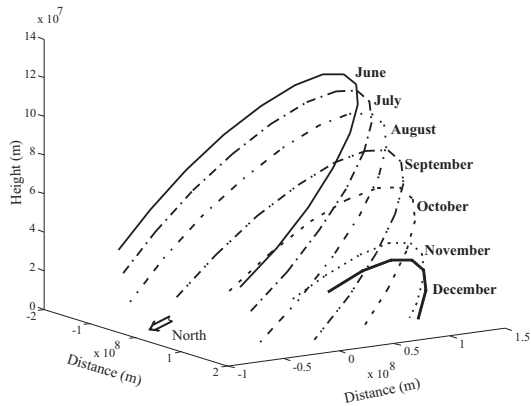

Fig. 6. Simulation of real sun path at Latitude 31.0°

Fig. 7 shows a comparison between the percentage of solar radiation without panel orientation (dashed line) and with panel orientation between -60° and $+60^\circ$ (solid line). The angle of orientation is the resultant of the two orientation angles (Azimuth and Altitude) and is equal to the angle of incidence of the sun on the panel's surface. The sun stays perpendicular on the surface during the orientation period (-60° to $+60^\circ$) and it begins to incline out of this range. It is clear from the simulation that the energy loss out of the specified range is relatively small. This simulation result proves that orientation saves more than 40% of the solar radiation and that the Azimuth angle can be limited between -60° and $+60^\circ$ without major losses in solar energy.

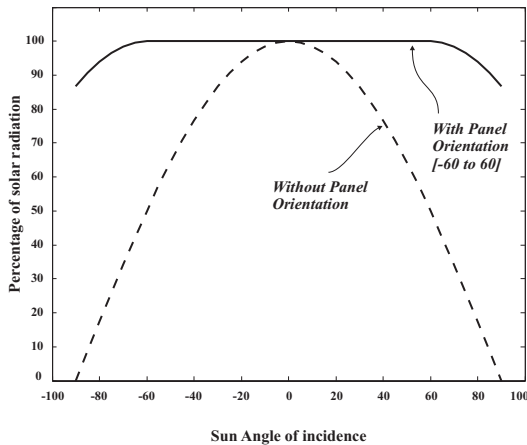

Fig.7. Comparison simulation of the system with and without contro

The orientation behavior of the photovoltaic panel has been simulated for different months in order to show the range of variation of the angles' values. Fig. 8 shows the rate of change of the Azimuth and Altitude angles of the orientation system as a function of time for the different months. The simulation is limited between 7 O'clock in the morning and 5 O'clock in the afternoon. Fig. 8(a) shows that in June, the Altitude angle ranges from 20° in morning and afternoon to 80° at noon while the Azimuth angle of the system ranges from -90° at 9 O'clock in the morning to $+90^\circ$ at 3 O'clock in the afternoon. In December, the Altitude angle ranges from 0° in morning and afternoon to a maximum value of 40° at noon where the Azimuth angle ranges from -60° at 7 O'clock in the morning to $+60^\circ$ at 5 O'clock in the afternoon. It is obvious that the Altitude angle reaches its maximum value at noon where the Azimuth angle is zero. These results facilitate the design of the pointing open-loop controller.

4 Dynamics

The orientation control system is a two degrees of freedom rotational mechanism. The outputs of this pointing system are the two orientation angles θ_z and θ_A . Fig. 9 depicts a block diagram for the system including the kinematics and dynamics of the solar panel. V_z and V_A are the voltages needed to drive the DC motors and steer the panel to the desired position acting with torques τ_z and τ_A respectively.

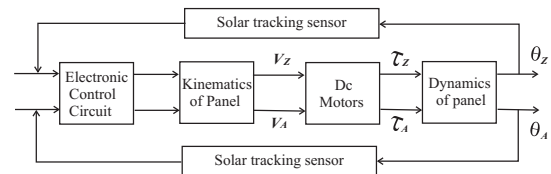

Fig. 9. Block diagram of the dynamic control system

Two control techniques can be applied here:

1. Open-loop control technique that depends on calculating the voltage corresponding to the output angles and feeding them into the motors.
2. Closed-loop technique which depends mainly on the signals sent by the two solar tracking sensors attached at the surface of the panel. The function of these sensors is to detect the position of the sun and feed the signal back to the electronic control circuit which in turn sends the signals to the motor to correct the real position of the panel perpendicular to the sun.

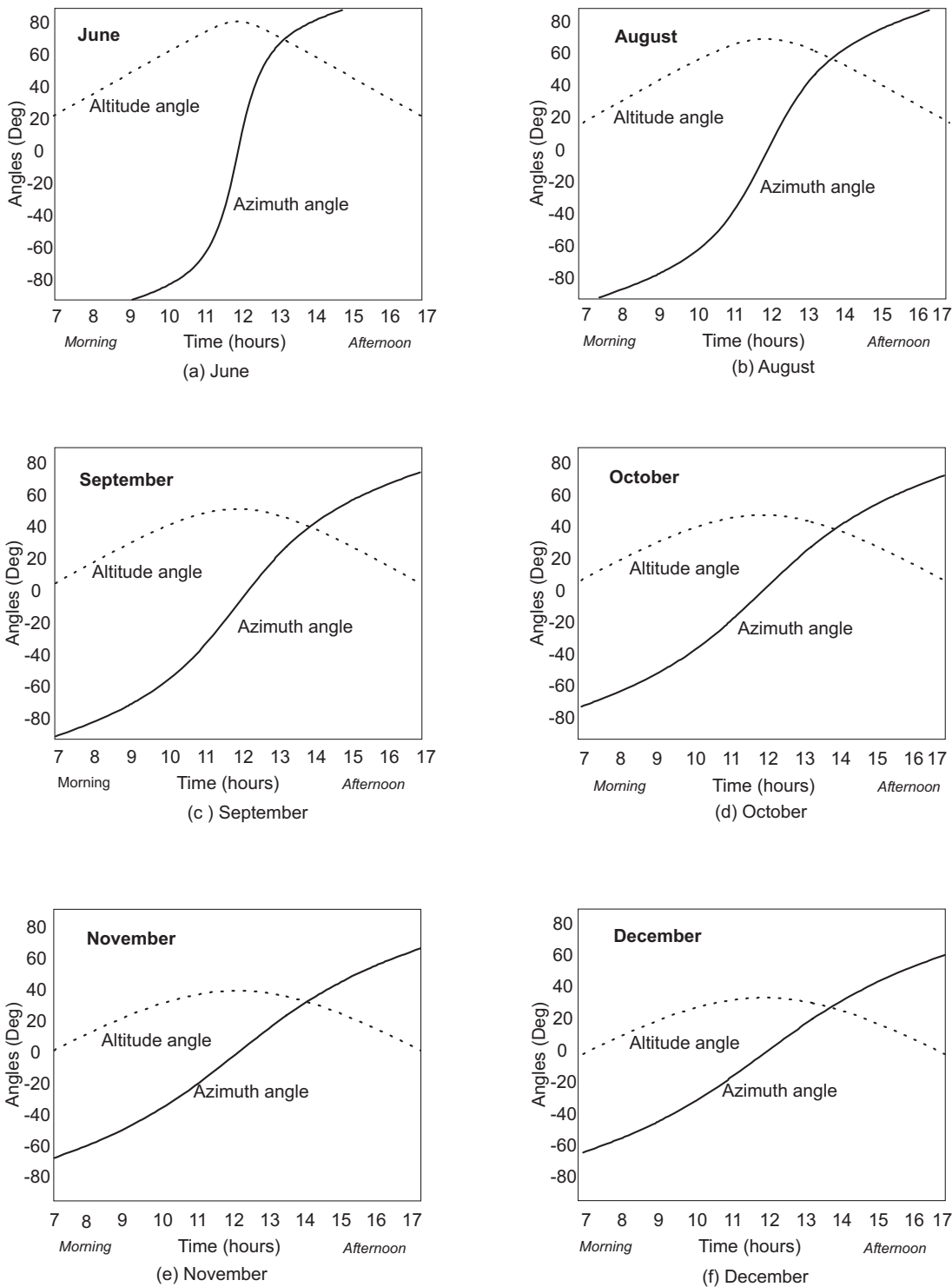

Fig. 8. Altitude and Azimuth angles for different months

Each technique has its advantages and drawbacks, where the open-loop technique is safe and continuous but it needs to keep the motors operating all the time even when there is no sun in the cloudy days. The closed-loop technique saves power because it turns the motors on when the sun is shining only, while the system stops working in cloudy periods. The main disadvantage of the closed-loop technique is that it is expensive to be applied that it needs sensors, electronics and control kits. The suggested technique here is to use sun detecting sensors that can send an ON-OFF switch signal for the open-loop system without being responsible for the tracking process. These sensors stop the system when the sky is cloudy and switch the system on again when sun shines positioning the panel in a calculated position according to time and date changes as shown in the Kinematics section. A timer can be used to return the whole system pointing towards the east after sunset to put the panel in a ready position facing the sun in the next morning.

Consider the schematic drawing of the system shown in fig. 10. In this drawing, a and b are the dimensions of the rectangular plate panel, d is the perpendicular distance from the center of gravity of the panel to the point of action of the rotating motor. θ_z and θ_A are the Altitude and Azimuth angles, respectively. τ_z and τ_A are the torques produced by the motors around the Altitude and the Azimuth directions respectively. These torques are responsible for the rotation of the two degrees of freedom of the system.

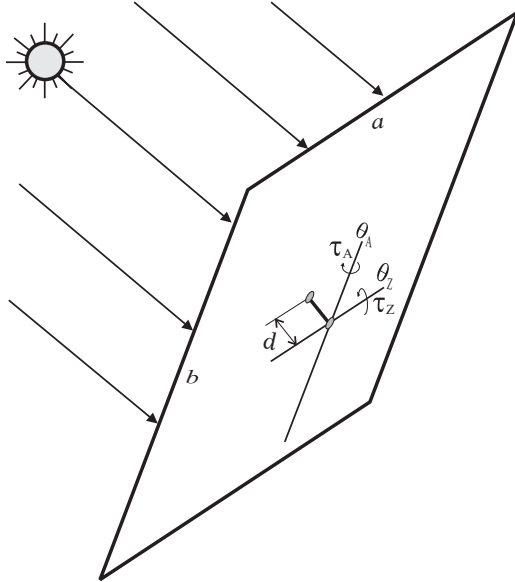

Fig. 10. Configuration and angles of the oriented panel

The polar moment of inertia about the Altitude axis is defined by $(J_z = \frac{1}{12}mb^2 + md^2)$ where m is the total mass of the solar panel with the frame. The moment of inertia of the panel about the Azimuth axis is defined by $(J_A = \frac{1}{12}ma^2 + md^2)$. The two second order differential equations of motion governing the system are defined by:

$$\begin{aligned} J_z \ddot{\theta}_z + C_z \dot{\theta}_z + K_z \theta_z &= \tau_z \\ J_A \ddot{\theta}_A + C_A \dot{\theta}_A + K_A \theta_A &= \tau_A \end{aligned}$$

Where J_z and J_A are the moments of inertia defined earlier, C_z and K_z are the damping coefficient and stiffness of the joint about the Altitude axis and C_A and K_A are the damping coefficient and stiffness of the joint about the Azimuth axis. The inputs of the system are the two torques τ_z and τ_A and the outputs of the system are the two orientation angles θ_z and θ_A . Taking the two angles and their derivatives (angular speeds) as the states of the system, the State Space model reads:

The system matrix is

$$A = \begin{bmatrix} 0 & 1 & 0 & 0 \\ -J_z^{-1}K_z & -J_z^{-1}C_z & 0 & 0 \\ 0 & 0 & 0 & 1 \\ 0 & 0 & -J_A^{-1}K_A & -J_A^{-1}C_A \end{bmatrix}$$

The input matrix is

$$B = \begin{bmatrix} 0 & 0 \\ J_z^{-1} & 0 \\ 0 & 0 \\ 0 & J_A^{-1} \end{bmatrix}$$

The output matrix is

$$C = \begin{bmatrix} 1 & 0 & 0 & 0 \\ 0 & 0 & 1 & 0 \end{bmatrix}$$

The feedthrough matrix is

$$D = \begin{bmatrix} 0 & 0 \\ 0 & 0 \end{bmatrix}$$

The frequency response function between the torque as an input and the orientation angle as an output is depicted in Fig. 11. This bode plot is identical for the

two degrees of freedom assuming that the panel is square and symmetric which leads to complete decoupling between the modes. This decoupling is very essential and facilitates the ability to use a decentralized control technique

It can be seen from fig. 11 that the system behaves like a low-pass filter where the low frequency torques of the pointing system are passed faithfully while the high frequency disturbances (higher than 5 Hz which is the corner frequency of the system) are isolated and cut-off. This gives the indication that the system will succeed in passing the torques needed for positioning without being deteriorated by the high frequency noise coming from the environment unless this noise is slower than the corner frequency. In other words, it can be stated that the lower the corner frequency of the system, the better the orientation system. This can be achieved by decreasing the stiffness of the joints as much as possible without getting close to the pointing frequency.

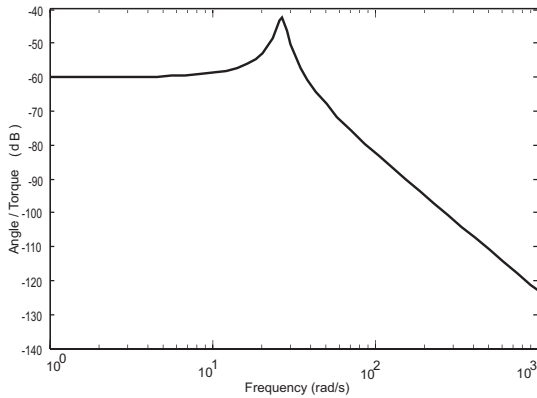

Fig. 11: Frequency response function between the torque as an input and the angle as an output

5 Grid design

The orientation system is designed to rotate the Altitude angle θ_z from 0° in winter to a maximum angle of 80° in summer and the Azimuth angle θ_A from -60° in the morning to $+60^\circ$ in the afternoon. The individual rotation of each panel is accompanied with the problem of shadow when panels come in front of each others. This problem can be solved by using a special grid arrangement where the distance between panels in the same row and the distance between the rows is set to be twice the dimension of the panel with an alternate installation as shown in Fig. 12.

This displacement and alternate installation needs larger space for the grid and is considered as a disadvantage of the system in limited areas because it leads to a compulsory decrease in the number of installed panels. In desert and open spaces, this is not considered as a

serious problem because of the availability of needed space without restrictions.

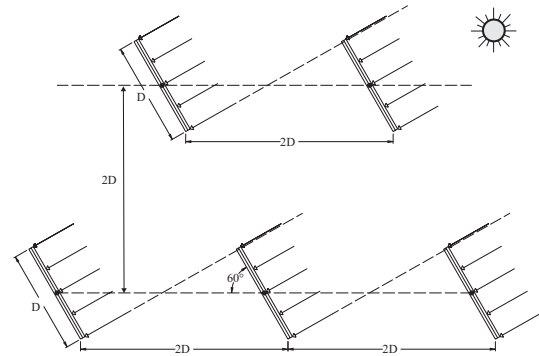

Fig. 12. Panel installation in the grid

4 Conclusion

From the foregoing discussion, it is clear that solar panel orientation is a real need especially in the desert regions to improve the efficiency of the photovoltaic panels. Two degrees of freedom orientation is feasible and can be done utilizing part of the power output of the solar panel. Kinematics of the system are simple and can easily be controlled using astronomic geometric calculations taking into account the symmetry of the system. Dynamics show that the orientation system behaves like a low-pass filter which facilitates the pointing operation. This behavior enables the controller to pass, faithfully, the low frequency torque signals needed for the pointing operation (these signals are lower than the corner frequency of the system) and to cut-off the high frequency disturbances. Some passive damping can be added to the joints to reduce the overshoot at the corner frequency.

Two control techniques can be applied here, open-loop with point to point intermittent motion resulting from the DC motors and closed-loop control technique using solar tracking sensors to track the sun in the cloudy days. A hybrid control technique is proposed here by using the signal coming from the solar tracking sensors as an ON-OFF switch for the open-loop system. The open-loop part of the controller is designed to rotate the panel from -60° to $+60^\circ$ stopped by limit switches at the end of the track. Other stops for the orientation system are guided by the solar tracking sensors when it is cloudy or partly cloudy. Digital programmable timer is used for the repositioning of the panel towards the east to be ready for the next morning.

References:

- [1] Palestinian Ministry of Local Government, *Guidelines for Energy Efficient Building Design*, Bailasan, 2004.
- [2] C. Alan Nicholas and P.E. CEM, *The tracking Solar Cooker*, Tucson, Arizona, 1993.
- [3] Manfred Kohler, Marco Shmidt, Michael Laar, Ulrike Wachsmann and Stefan Krauter, 'Photovoltaic Panels on Greened Roofs, Positive Integration Between Two Elements of Sustainable Architecture', *R10 02 – World Climate & Energy Event*, January, pp6-11, 2002.
- [4] Toby Peterson, Justin Rice and Jeff Valane, *Solar Tracker*, Final Project in Cornell University, ECE 476, Spring 2005.
- [5] Whittaker, W., Kantor, G., Shamah, B. and Wettergreen, D., 'Sun-Synchronous Planetary Exploration', *AIAA*, 2000.
- [6] Bong Wie, 'Dynamic Modeling and Attitude Control of Solar Sail Spacecraft', *JPL Contract, NASA Solar Sail Technology Working Group*, January 2002.
- [7] John Murphy and Ross Crowley, 'Optimal Solar Tracking System', US Patent no. (5,816,540) , October, 1998.
- [8] Mohammed Faheem Khan and Rana Liaqat Ali, *Automatic Sun Tracking System*, Air University, Islamabad, Pkistan, 2003.
- [9] Harry A. Sorensen, *Energy Conversion Systems*, John Wiley & Sons, 1983.
- [10] Minister of Natural Resources of Canada, *Clean Energy Project Analysis*, 2005.
- [11] J., C., McVeigh, *Sun Power*, 2nd ed., Pergamon Press, 1983.