

Performance Predication of Solar Assisted Chemical Heat Pump Drying System in Tropical Region

M. IBRAHIM, K. SOPIAN, W.R.W. DAUD, M. YAHYA, M. A. ALGHOUL and A. ZAHARIM

Solar Energy Research Institute
Universiti Kebangsaan Malaysia
43600 Bangi Selangor
MALAYSIA

Abstract: - This paper presents evaluation for the performance of solar assisted chemical heat pump for drying purpose. The system consists of four main components, solar collector (evacuated tubes type), storage tank, chemical heat pump units and dryer chamber. A simulation has been done under the meteorological conditions of Malaysia. The monthly efficiency for evacuated tube solar collector has been predicted to be between the range (59 – 64%) with the deference between mean collector temperature and ambient temperature 20 °C. The solar fraction as a function of solar collector area has been studied. It was found that as the collector area increases the loss increases and hence the solar fraction increases. A monthly coefficient of performance for heating (COP^h) for chemical heat pump has been predicted and the maximum value of 1.8 were found. Any reduction of energy at condenser as a result of the decrease in solar radiation which in the final decrease the coefficient of performance as well as decrease the efficiency of drying.

Key-Words: - evacuated tube collector efficiency, solar fraction, collector area, chemical heat pump, coefficient of performance, drying.

1 Introduction

In recent years, considerable importance has been placed on the rational use of energy resources. The depletion of conventional energy resources and its adverse impact on environment have created renewed interest for the use of renewable energy resources. As a result, considerable research and development activities have taken place to identify reliable and economically feasible alternate clean energy sources. The choices for the alternate energy sources are: energy from sun, wave, wind and geothermal etc. Along with this, other solutions like waste energy recovery using heat pump have found significant attention in recent years. As far as the economical aspect is concerned, the importance of this heat recovery cannot be under stated, as the resulting energy efficiency is considerably high [1]. Heat pump dryers have been known to be energy efficient when used in conjunction with drying operations. The principal advantages of heat pump dryers energy from the ability of the heat pumps to recover energy from the exhaust gas as well as their ability to control the drying gas temperature and humidity. Heat pumps have been extensively used by industry for many years, although their application to process drying and, in particular, to drying textile products is relatively lower. The

studies on HPDs can be classified in three groups. The first group includes studies in which the performance analysis of these systems has been investigated [2-5], while the second group covers studies on developing simulation models [6-8]. The investigations on the application of HPDs to drying systems for industrial use belong to the last group [5, 9, 10]. In most of these studies, food products and agricultural materials were dried in various types of HPDs. A chemical heat pump (CHP) is proposed as one of the potentially significant technologies for effective energy utilization in drying. The CHP can store thermal energy such as the waste heat from dryer exhaust, solar energy, geothermal energy, etc. in the form of chemical energy, and release the energy at various temperature levels during the heat-demand period. In this study the simulation has been conducted to predict the performance of solar assisted chemical heat pump drying system under the meteorological conditions of Malaysia

2 System Description

The schematic of the solar chemical heat pump dryer system with integrated storage tank system is shown in Figure 1. The system consists of four main components solar collector (evacuated tubes type), storage tank, chemical heat pump unit and

dryer chamber. In this study, a cylindrical tank is selected as a storage tank. The chemical heat pump unit contains of reactor, evaporator and condenser. In the chemical heat pump a solid gas-reactor coupled with a condenser or an evaporator. The reactor contains a salt which reacts with the gas, the reactions used in this study is:

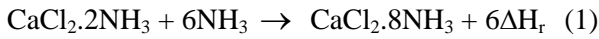

Where ΔH_r is the enthalpy of chemical reaction for chemical heat pump.

The drying chamber contains multiple trays to hold the drying material and expose it to the air flow. The general working of chemical heat pump occurs in two stages: adsorption and desorption. The adsorption stage is the cold production stage, and this is followed by the regeneration stage, where decomposition takes place. During the production phase, the liquid-gas transformation of ammonia produces cold at low temperature in the evaporator. At the same time, chemical reaction between the gaseous ammonia and solid would release heat of reaction at higher temperature. In heat pump, heat is supplied to the reactor (by utilizing energy sources such as solar energy) at high temperature to regenerate ammonia which will then be condensed in the condenser at medium temperature. The heat required at evaporator at low temperature is supplied to vaporize ammonia which reacts with salt and releases heat at medium temperature. The incoming air is heated by condensing refrigerant (ammonia) and enters the dryer inlet at the drying condition and performs drying. After the drying process, part of the moist air stream leaving the drying chamber is diverted through the evaporator, where it is cooled, and dehumidification takes place as heat is given up to the refrigerant (ammonia). The air is then passing through the condenser where it is reheated by the condensing refrigerant and then to the drying chamber.

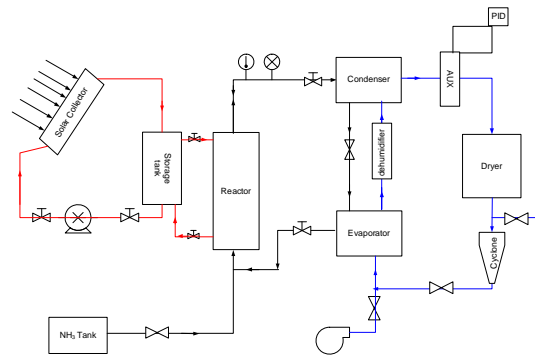

Fig.1 Schematic diagram of solar assisted chemical heat pump dryer

3 Theoretical Background

The development of mathematical models for different components of the system is essential before the simulation program of the system is considered for evaluation the performance. In the solar collector the useful energy gain of collector surface area is given by the following equation [11]:

$$Q_u = \eta A_C I \quad (2)$$

Where η is the collector efficiency, A_C is the collector area and I is the instantaneous solar radiation incident on the collector per unit area.

The collector efficiency for the evacuated tube collector is given by [12]:

$$\eta_{eva} = 0.84 - 2.02(T_m - T_a) / I - 0.0046[(T_m - T_a) / I]^2 \quad (3)$$

Where T_m is the mean collector temperature and T_a is the ambient air temperature.

In this study, a cylindrical tank is selected as a storage tank. The heat loss from the tank on ground is calculated by:

$$Q_s = (UA)_{strg} (T_{col} - T_a) \quad (4)$$

Where Q_s is the heat loss from the storage tank, T_{col} is the collector area and $(UA)_{strg}$ is the loss coefficient of storage tank and calculated using the following equation [13]:

$$(UA)_{strg} = \frac{A_s}{\frac{k}{d} + \frac{1}{h}} + (UA)_{gnd} \quad (5)$$

Where k and d are the thermal conductivity and thickness of insulation and h is the convective

heat transfer coefficient. In this study, the conduction resistance of the tank wall is neglected because the wall thickness is very thin. A_s represents the exposed area and $(UA)_{gnd}$ represents heat loss through ground from the bottom of the tank and is neglected because there is no loss with the ground for this study.

In the chemical heat pump a solid gas-reactor, coupled with a condenser or an evaporator. The reactor contains a salt which reacts with the gas, in the chemical heat pump heat is supplied to the reactor at high temperature to regenerate ammonia which will then be condensed in the condenser at medium temperature, the heat required to evaporator at low temperature is supplied to vaporize ammonia, which reacts with salt and release heat at medium temperature. The heating performance for chemical heat pump could be defined as:

$$COP^h = \frac{Q_c + Q_r}{Q_r} = \frac{\Delta H_c + \Delta H_r}{\Delta H_r} \quad (6)$$

Where Q_c is the condenser heat rejection, Q_r is the reaction heat and ΔH_c is the enthalpy of condensing. And for the integrated heat pump with solar collector and storage tank the heating performance of chemical heat pump could be:

$$COP^h = \frac{Q_c + Q_r}{(Q_u - Q_s) + Q_r} \quad (7)$$

The Solar Fraction (FR) is defined as the utilized solar heat divided by the total heat demand and calculated from the following relationship:

$$FR = \sum [Q_u - Q_s] / Q_c \quad (8)$$

4 Results and Observations

Simulations were performed for Sepang location in Malaysia, which is at latitudes 3.1N. The data for the monthly average solar radiation on a horizontal surface and the monthly average outside air temperature of this location are shown in Figure 2.

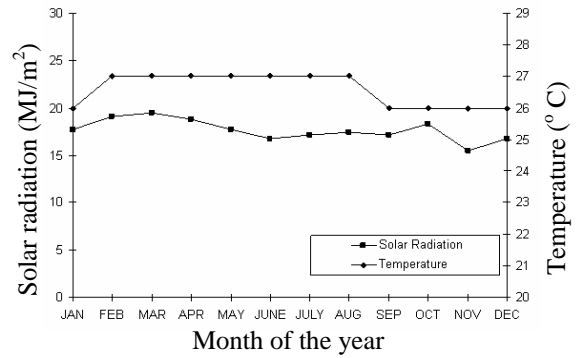

Fig. 2 Monthly weather data for Sepang

Efficiency curve for the evacuated tube collector is plotted in Fig. 3, as a function of $(T_m - T_a)$ (°C). It can be seen that the efficiency decrease with the higher difference temperature. Figure 4 shows the monthly predicted of the efficiency of evacuated tube collector which is the maximum can get 64% as shown in the figure, and figure 5 shows the monthly predicted of useful energy with the maximum value can be getting around 1300W. Figure 6 shows the monthly predicted solar fraction as a function of solar collector area while figure 7 shows the annual solar fraction predicted curve as a function of solar collector area for different storage tank sizes. In figure 6 the monthly solar fraction increase with the collector area but at a decreasing rate. The reason for this is that the larger the collector size, will give higher losses. Moreover, the higher the collectors size the higher will be the collector inlet temperature and will decrease the collector efficiency. Figure 7 shows that the annual solar fraction increases as a result of increasing the storage tank size. Figure 8 shows predicted monthly values of coefficient of performance for chemical heat pump. As seen in the figure the maximum COP for chemical heat pump 1.8 were found. If there is a reduction in the energy available at the condenser as a result of a decrease in solar radiation as well as the decrease in latent heat contribution from the drying material as the drying progresses.

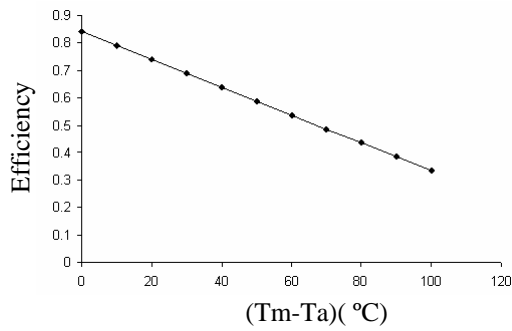

Fig. 3 Characteristics curve of vacuum tube with the temperature difference of mean collector temperature and ambient temperature.

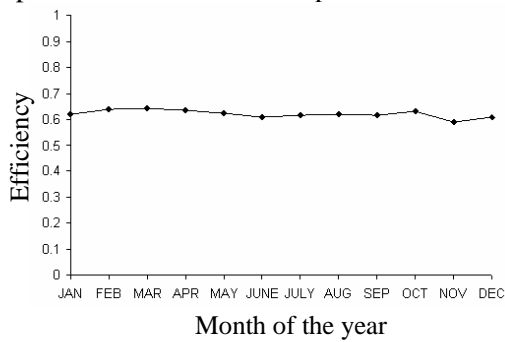

Fig. 4 Monthly efficiency predicted curve of evacuated tube

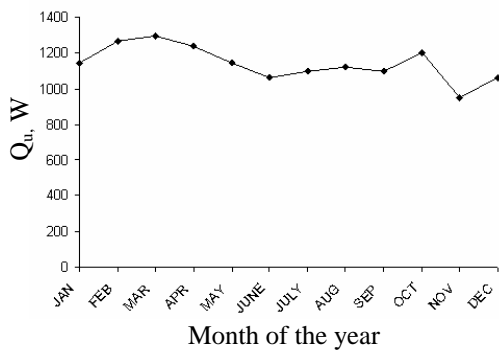

Fig. 5 Monthly useful energy predicted curve

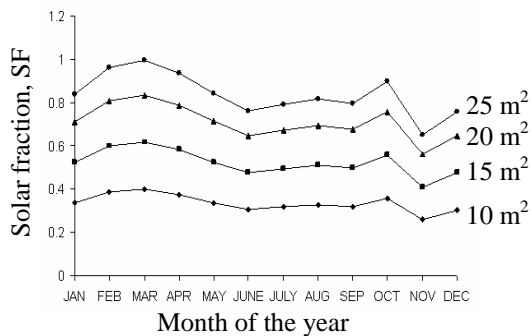

Fig. 6 Monthly solar fraction predicted curve as function of solar collector area

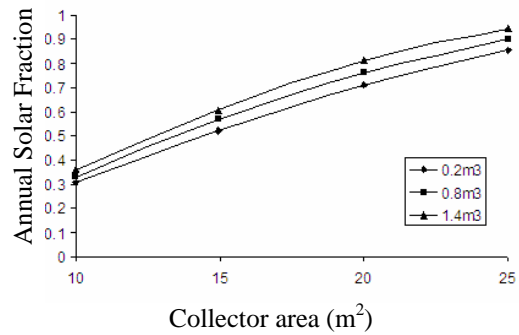

Fig. 7 Annual solar fraction predicted curve as function of solar collector area.

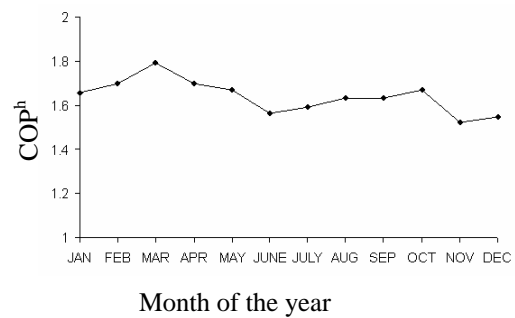

Fig. 8 Monthly coefficient of performance predicted curve for a collector of 10 m² area and storage tank size of 0.2 m³

5 Conclusion

A simulation has been developed to predict the performance of solar assisted chemical heat pump under the meteorological Malaysia condition. Values of the COP and SF of the system as high as 1.8 and 0.4 as function for solar collector area 10 m², respectively. Efficiency of 64% was predicted for evacuated tubes collector. The results show that any reduction of energy at condenser as a result of a decrease in solar radiation which in the final decrease the coefficient of performance as well as decrease the efficiency of drying.

References:

- [1] M. Hawlader and K. Jahangeer, Solar Heat Pump Drying and Water Heating in the Tropics, *Solar Energy*, 80(5), 2006, 492-499.
- [2] EL. Schmidt, K. Klocker, N. Flacke and F. Steimle, Applying the Transcritical CO₂ Process to a Drying Heat Pump, *Int J Refrig*, 21(3), 1998, 202-211.
- [3] D. Isin, Computer Simulation of a Solar

Assisted Heat Pump System, *MSc thesis in mechanical engineering department*, Middle East technical university, Ankara, Turkey, 1991.

- [4] S. Clements, X. Ha and P. Jolly, Experimental Verification of a Heat Pump Assisted Continuous Dryer Simulation Model, *Int J. Energy Res*, 17, 1993, 19-28.
- [5] M. Hawlader, T. Bong and Y. Yang, A Simulation and Performance Analysis of a Heat Pump Batch Dryer. In: Mujumdar AS, Series editor. *Proceedings of the 11th international drying symposium*, Halkidiki, Greece, August 19-22, 1998, 208-215.
- [6] P. Jolly, X. Jia and S. Clements, Heat Pump Assisted Continuous Drying part 1: Simulation Model. *Int J. Energy Res*, 14, 1990, 757-770.
- [7] P. Chen and D. Pei, A Mathematical Model of Drying Processes, *Int J Heat Mass Transfer*, 32 (2), 1989, 297-310.
- [8] X. Jia, P. Jolly and S. Clemets, Heat Pump Assisted Continuous Drying part 2: Simulation Results. *Int J. Energy Res*, 14, 1990, 771-82.
- [9] R. Mason, P. Britnell, G. Young, S. Birchall, S. Fitzpayne and B. Hesse, Development and Application of Heat-Pump Dryers to the Australian Industry. *Food Aust*, 46, 1994, 319-322.
- [10] H. Ogura and A. Mujumdar, Proposal for a Novel Chemical Heat Pump Dryer. *Drying Technology* 18, 2000, 1033-1053.
- [11] JA. Duffie and WA. Beckman, *Solar Engineering of Thermal Process*, 2nd Ed. New York: Wiley Interscience; 1991.
- [12] A. Ucar and M. Inalli. Thermal and Economic Comparisons of Solar Heating Systems with Seasonal Storage Used in Building Heating, *Renewable Energy*, 33(12), 2008, 2532-2539.
- [13] M. Chung, J. Park and H.Yoon, Simulation of a Central Solar Heating System with Seasonal Storage in Korea. *Solar Energy*, 64, 1998, 163-78.