

Adaptive Control of the Active Power of an Electric Arc Furnace

MANUELA PANOIU¹, CAIUS PANOIU¹, IOAN SORA, ANCA IORDAN¹

¹Electrical Engineering and Industrial Informatic Department

Polytechnic University of Timisoara

Revolutiei street, no 5 Hunedoara, cod 331128

² Electrical Engineering Faculty

Polytechnic University of Timisoara

Bd. V. Parvan, no. 2, Timisoara, cod 300223

ROMANIA

Abstract: - The electric arc furnaces are a very large power load, determining the negative effects on the power quality (harmonics currents, unbalanced load, and reactive power). For a maximum efficiency of the power consumption it is necessary to use an automat system of electrodes position control, in order to obtain a high value of power factor and a maximum efficiency. In this paper is present an adaptive method for process control for an Electric Arc Furnace. The method was validate using simulation.

Key-Words: - Adaptive control, LMS algorithm, active power control

1 Introduction

In present the EAF (Electric Arc Furnaces) are very large used to the steel making industry. But, the electrical installations of the electric arc furnaces are generators of the reactive power, harmonics currents and unbalanced currents. These effects are very harmful for the electric power supplying line and for the others consumers. Because the inductive load character of the electric arc furnace, the reactive power component are significant, following to the diminution of the active power factor and therefore to the decreasing of the efficiency of the electric arc furnace. In scope of improving the efficiency of the entire installation it is necessary to use a complex installation for reactive power compensation, harmonics current filters and load balancing. These installations must be connected to an automat system for an efficient real-time control.

2 Designing the control system of the EAF

The design of the control system was made following the measurements made in an industrial plant. The measurements were made at a 3-phase power supply installation of a 3-phase EAF of 100 t, to which were not connected the filters for the current harmonics, neither the load symmetrization device or reactive power compensation. The detailed results of these measurements were presented in [7]. From the ones previously presented resulted that the

elements that contribute to the development of an action concerning the improvement of the electric power's quality can be grouped in:

- the capacitors fix battery in Y connection used for compensation of the constant reactive power;
- 14 capacitors battery independently connectable, in Y connection, used for compensation of the variable reactive power;
- an Adaptable Balancing Compensator (ABC) achieved with 3 susceptances controlled by thyristors in Δ connection used for load balancing as well as for the compensation of the difference between the reactive power installed in the capacitors' batteries and harmonic filters and the necessary of reactive power until the obtaining of a unitary power factor;
- 4 filtration blocks of filter in Y connection used for filtration of current harmonics 5,7,11 and 13.

Using of these installations aiming the fulfillment of the functions for which they were designed need the utilization of an intelligent system of their control. This must fulfill the following conditions:

- to allow the on-line determination of the electric values of the EAF's installation;
- to calculate the necessary step for compensating the reactive power as well as the value of the susceptances necessary for load balancing. Based on these values, having in view the chosen constructive solution of adjustable susceptance with tyristors, is calculated the control angle of each tyristor;

- to allow the connecting – disconnecting command from the medium voltage line of the capacitors batteries, filters on harmonics and the balancing installation;
- to allow the control of entering in conduction of each independent thyristor;
- to display on-line the values of the electric measures.

The diagram of the control system proposed to be used at the load's compensation – balancing – filtration is depicted in fig. 1.

In [7], [8] and [5] was calculated the values of these elements.

3 Simulation of the EAF functioning

For validating the proposed control system it was made a simulation of the EAF using PSCAD EMTDC simulation program [10]. For simulation it was use an electric arc model, depending on the nonlinearity of the electric arc. This model was presented in [7] and [8]. Based on this model it was made a simulation for the entire electrical installation of the EAF and for the propose control system. The PSCAD simulation scheme is depicted in fig. 2.

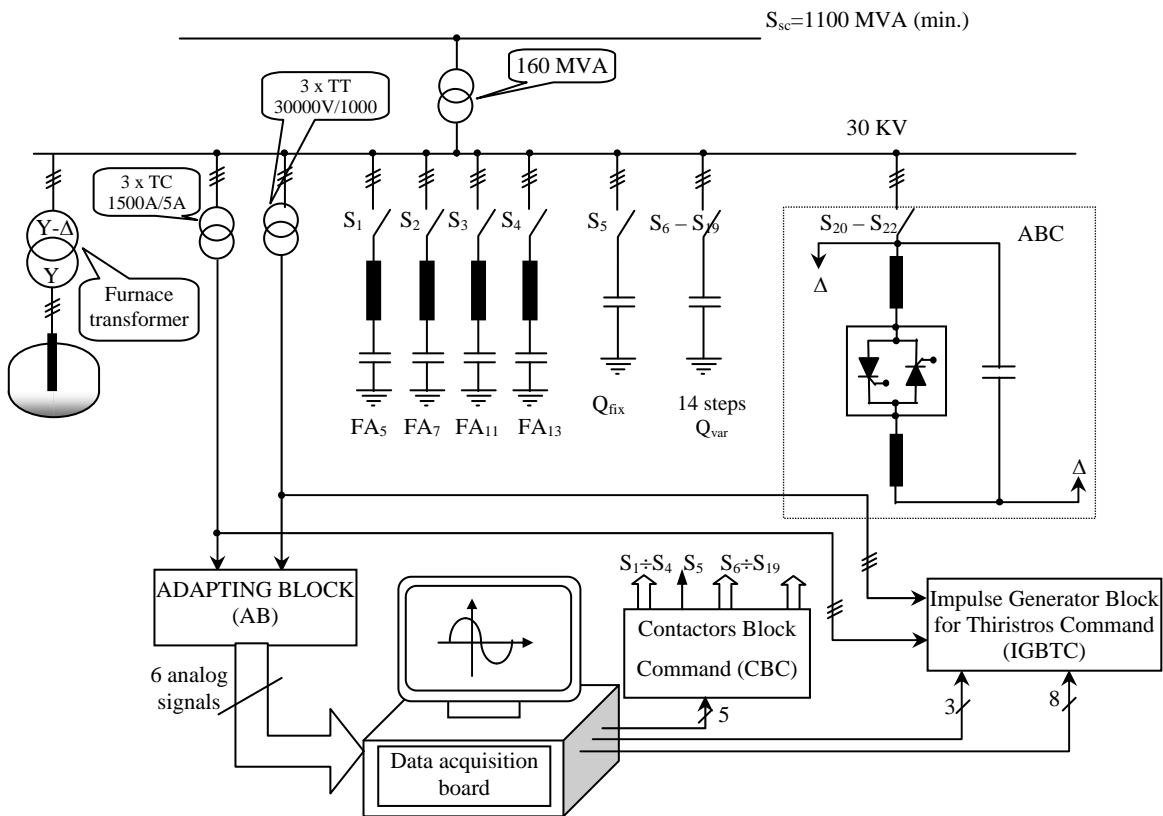

Fig. 1. The system diagram for process control of the EAF

3.1 The EAF functioning simulation on modifying the electrodes position

The electrical items variation in different functioning regimes can be done only if we consider an arc length variation between 0, corresponding to the short-circuit regime, and a maximum value. The maximum value is determined in such a way that the electric arc is burning. For observing the variation area of the powers on the supplying line the active power meters and reactive power meters was connecting like in figure 2. The outputs of these meters permit to obtain the rms values.

The electrodes position controlling is performed taking into account on the real condition existing on the considered industrial plant. The maximum motion speed of the electrodes is of 3 m/min (0.05 m/s) and is reached in emergency regime. The electric arc's length can be modified from zero to a maximum value. Adjustment of the electrodes' position is made independently on each phase. Simulation of the electric installation's operation modifying the electric arc's length was made initially without harmonics filters, power compensation or load balancing. It was considering the electric arc's initial value $l_0 = 16 \text{ cm}$ as well as

the electrodes' initial speed $v_1 = v_2 = v_3 = 0$ m/min. Then, was command the lowering-down of the electrodes up to the fulfillment of the short-circuit condition. After approximate 8 seconds it was

command, independently on each phase, the lifting-up of the electrodes with different speeds up to the considered maximum length of the electric arc $l_{max} = 26$ cm.

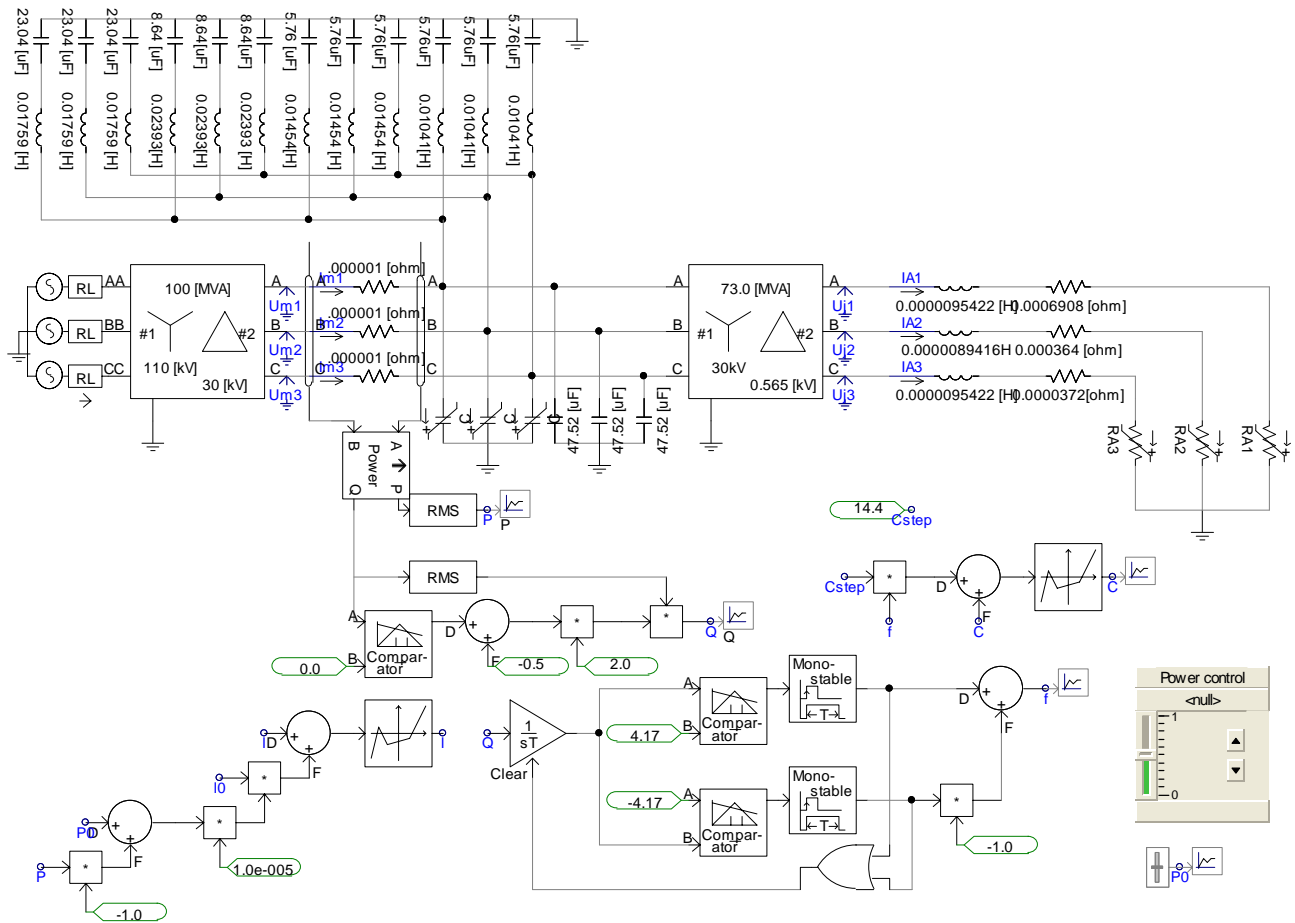

Fig. 2 The PSCAD simulation scheme for active power control

In this way it was covered practically the entire operation domain, from the short-circuit regime up to the fulfillment of the conditions in which the electric arc does not ignite anymore. The simulation results are presented in fig. 3. One can observe that the highest value of the active power is obtained when the value of the arc length is aprox. 16 cm. The reactive power is positive regardless the working regime, having values between 15-100 MVAR, being therefore necessary the utilization of the reactive power's compensation installation. One can observe that the domain in which the reactive power should be compensate is higher than the one chosen in case of designing the reactive power's compensation installation from [8]. This is due to the fact that the

simulation included also the short-circuit regime where the reactive power, considering the symmetrical short network, has, according to the circle's diagram, the value

$$Q_{sc} = \sqrt{2} \cdot S_{cn} = 103,23 \text{ MVAR} \quad (1)$$

In the electrodes' short-circuit regime are obtained maximum values of the currents on the three phases, on the both supply lines and minimum values of the voltages, fact due to the high loading of the 3-phase transformers. The rms values of the currents and voltages, fig. 4, are different between the phases because of the different values of the load impedance and because of the different values of the arc lengths on each phase.

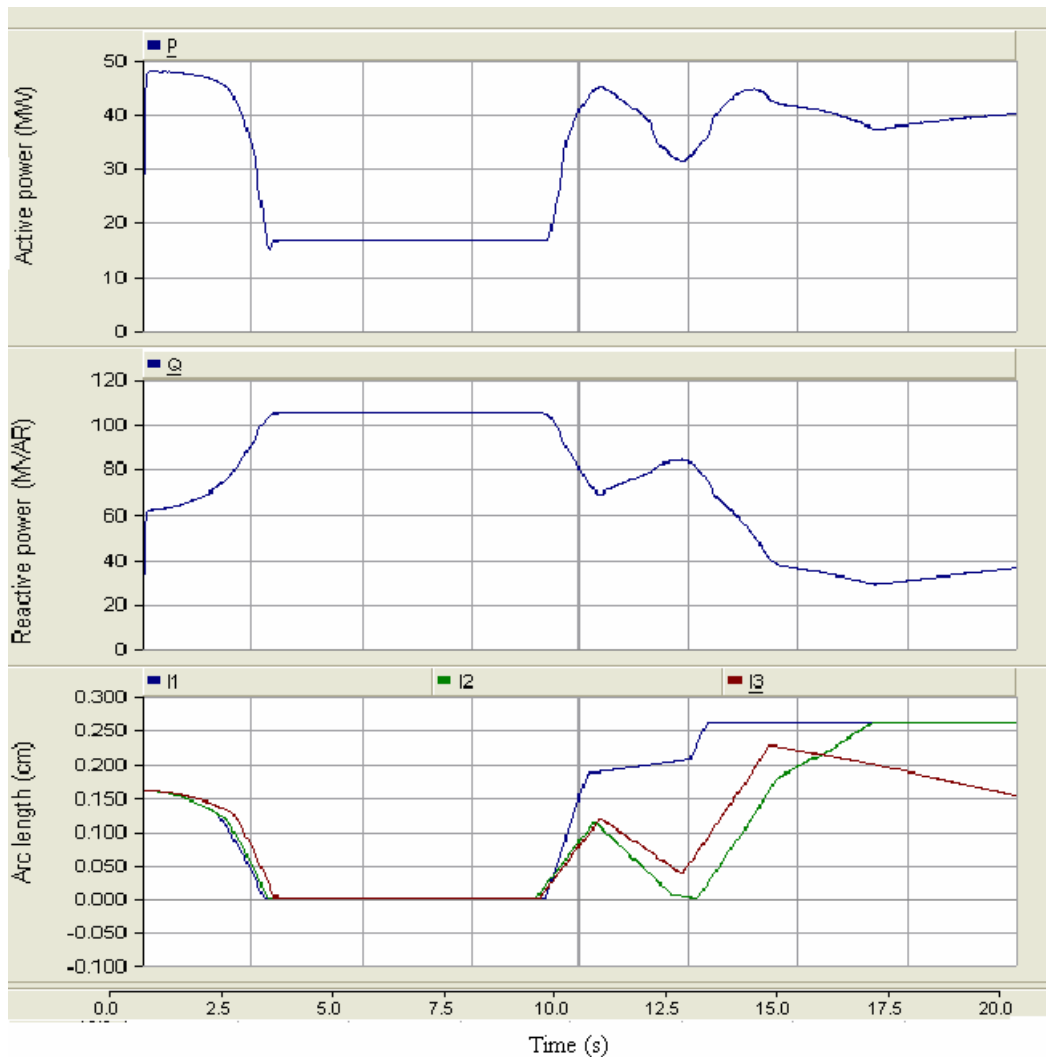

Fig. 3 The variation of the powers and of the arc length on the three phases

3.2 Simulation of the active power control system's operation following the reactive power's compensation and filtration of the harmonic currents

To simulate the operation of the power control system in different regimes using the reactive power's filtration and compensation installation, it was used the diagram presented in fig. 2. This condition contains the 4 filters on the harmonics 5,7,11 and 13 and the reactive power compensation installation composed by the constant part (in Y connection) and the adjustable part in steps. The values of the elements are the ones designed in [7] and [8].

To ensure the reactive power's compensation on the entire duration of the active power's control process it is necessary that, depending on the reactive power's momentary value, to connect or disconnect one compensation step at a time.

Choosing of the compensation step is made as follow:

- If the reactive power is situated within the range $-4,00 \div 4,00$ MVAR the compensation step does not modify;
- If the reactive power is higher than $4,00$ MVAR a new compensation step will be introduced;
- If the reactive power is lower than $-4,00$ MVAR a compensation step will be disconnected.

Since the extinction voltage depends linearly by the electric arc's length, it results that also the active power depends on the electric arc's length. Based on these remarks, the active power's iterative adjustment algorithm proposed by the de authors is based on the modification of the electric arc's length depending on the active power desired to be obtained.

Assuming that at iteration n the arc's length is $l(n)$, and the active power is $P(n)$, the arc's length at iteration $n+1$ will be given by the relation

$$l(n+1) = l(n) + \alpha \cdot e(n) \quad (2)$$

where

$$e(n) = P_0 - P(n) \quad (3)$$

are the error by which is obtained the imposed active power P_0 at iteration n , and α represents an *adapting factor*. It is obvious that if the value of the active power obtained at iteration n is higher than the value of the imposed active power P_0 is necessary to reduce the electric arc's length and opposite, fact ensured by the presented algorithm. [9]. This algorithm is known as the *LMS* algorithm

(Least Mean Square) or the stochastic gradient's algorithm, being, due to its simplicity, the most used algorithm implemented in the current systems. Choosing of the adapting factor's values is made taking into account its influence upon the algorithm's main characteristics: the algorithm's convergence speed and the adjustment error.

Were obtained the results presented in fig. 5 for an adapting factor's value $\alpha = 0,00001$.

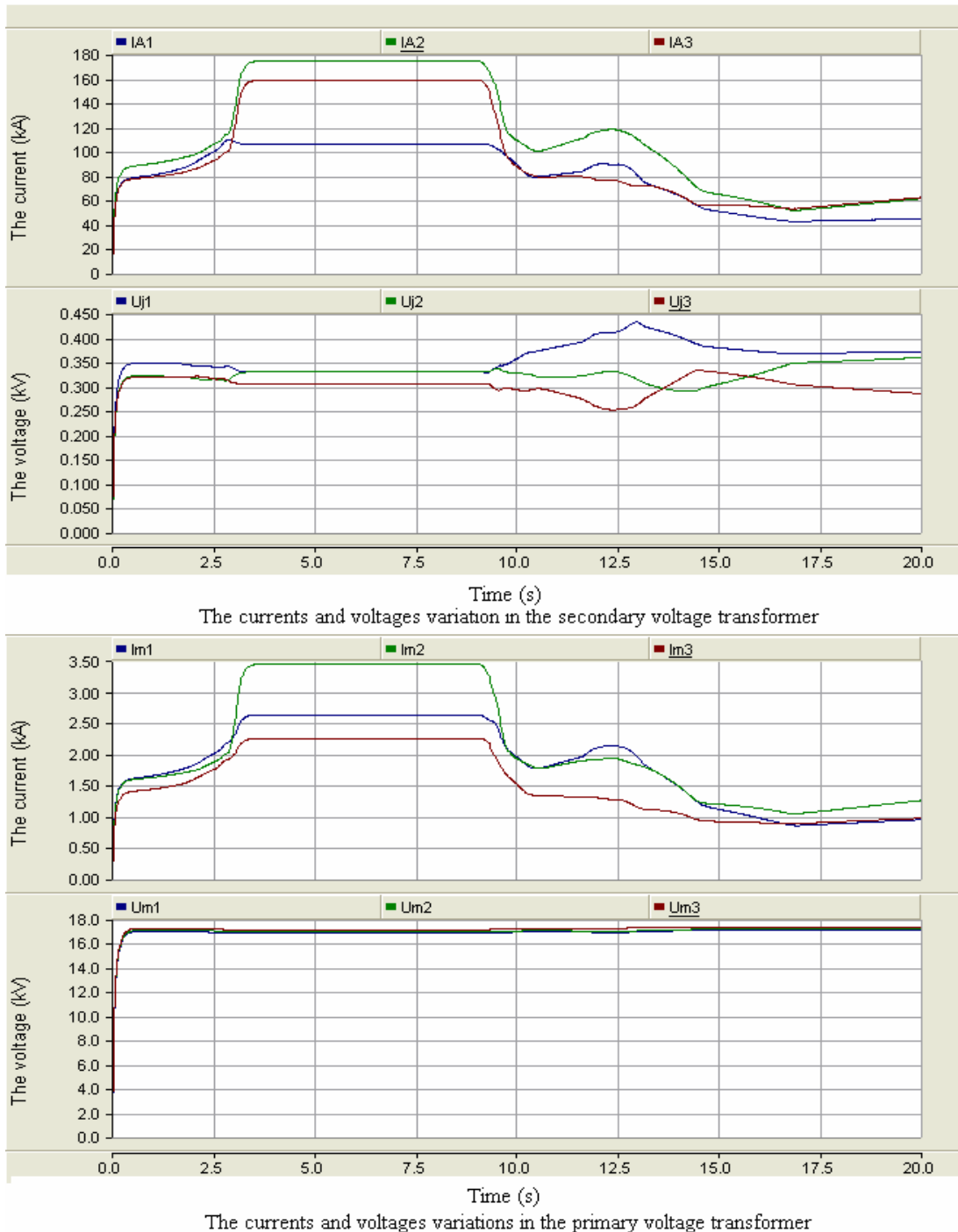

Fig. 4. The variation of the rms values of the currents and voltages in the secondary and primary voltage transformer

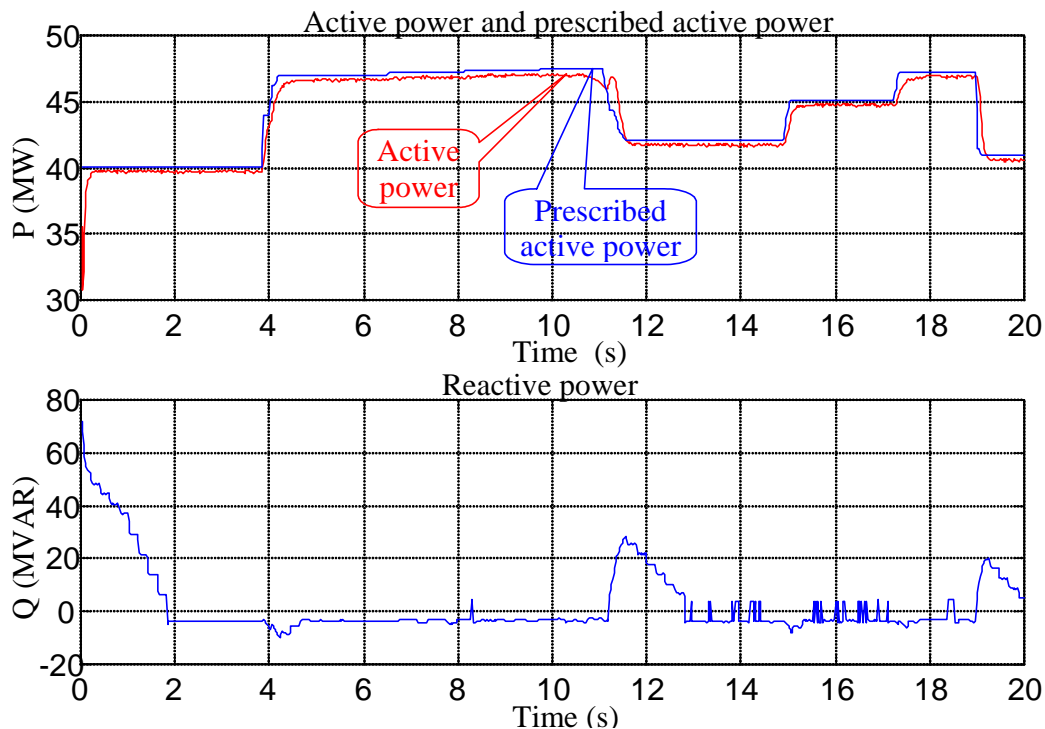

Fig. 5. The active power control using LMS algorithm

4 Conclusion

By using harmonics filters, load balancing and reactive power compensation the functioning regime of the UHP EAF can be improve by controlling the active power. For higher values of the adapting factor allow the obtaining of higher convergence speed of the control algorithm, but the dispersion obtained around the desired value is higher, the algorithm being possible to lose the convergence. Smaller values of the adapting factor allow the obtaining of a smaller dispersion of the system output's values but the convergence speed is smaller.

References:

- [1] "IEEE recommended practice for monitoring electric power quality". Standard IEEE std. 1159-1995
- [2] Montanari, G.C., Loggini, M., Cavallini, A., Pitti, L., Zaminelli, D. (1994), Arc-Furnace model for the Study of Flicker Compensation in Electrical Networks, *IEEE Transactions on Power Delivery*, vol. 9, No. 4, pg. 2026-2036.
- [3] Tang, L., Kolluri, S., Mark, F. Mc-Granaghan, Voltage Flicker Prediction for two simultaneously operated Arc Furnaces, *IEEE Trans. on Power Delivery*, vol. 12, No. 2, 1997.
- [4] Panoiu M, Panoiu C, Modeling and simulating the AC electric arc using PSCAD EMTDC, *Proceedings of the 5th WSEAS Int. Conf. on System Science and Simulation in Engineering*, Tenerife, Spain, Dec. 16-18, 2006
- [5] Panoiu M., Panoiu C., Osaci M, Muscalagiu I., Simulation Result about harmonics filtering for Improving the Functioning Regime of the UHP EAF, *Proceedings of the 7th WSEAS Int. Conf. on Signal Processing, Computational Geometry and Artificial Vision*, Vouliagmeni Beach, Athens, Greece, Aug. 24-26, 2007, pg. 71-76
- [6] Panoiu M., Panoiu C., Osaci M, Muscalagiu I., Simulation Results for Modeling the AC Electric Arc as Nonlinear Element using PSCAD EMTDC, *WSEAS Transaction on circuits and systems*, pp 149-156. vol 6, 2007
- [7] Panoiu M., Panoiu C., Osaci M, Muscalagiu I., Simulation Result about Harmonics Filtering using Measurement of Some Electrical Items in Electrical Installation on UHP EAF, *WSEAS Transaction on circuits and systems*, vol 7, Jan 2008, pp 22-31.
- [8] Panoiu M., Panoiu C., Jordan A., Rob R., Simulation Results Regarding High Power Loads Balancing, *Proceedings of the 12th WSEAS International Conference on Systems*, Heraklion Greece, 22-24 iulie, pag 614-619
- [9] Alexander, S. T., Adaptive Signal Processing, Springer Verlag New York Inc., 1986.
- [10] www.pscad.com