

## Sadi Carnot's Ingenious Reasoning of Ideal Heat Engine Reversible Cycles

MILIVOJE M. KOSTIC  
Department of Mechanical Engineering  
Northern Illinois University  
DeKalb, IL 60115  
U.S.A.

**Abstract:** - Sadi Carnot, at age 28, published in 1824, now famous “*Réflexions sur la puissance motrice du feu (Reflections on the Motive Power of Fire)*,” which is much more important than what it appears at first. It may be among the most important treatises in natural sciences. At that time, when heat was considered as indestructible caloric and the energy conservation law was not known, when heat engines were in initial stage of development with efficiency of less than 5%, the confusion and speculations flourished. Carnot’s reasoning of reversible cycles is in many ways equal if not more significant than the Einstein’s relativity theory in modern times. It led to discovery of Thermodynamic absolute temperature and entropy, and the far-reaching Second Law of Thermodynamics. No wonder that Carnot’s work was not noticed at his time, when his ingenious reasoning of ideal heat engine reversible cycles is not fully recognized, and may be truly comprehended by a few, even now. Additional reasoning and conclusions are also presented here.

**Key Words:** Sadi Carnot, heat engine, reversible process, Thermodynamic temperature, entropy, Second Law of Thermodynamics.

### 1. Introduction: Sadi Carnot’s Far-Reaching Treatise of Heat Engines Was Not Noticed at His Time and Even Not Fully Recognized Nowadays

No wonder that Sadi Carnot’s “*Réflexions sur la puissance motrice du feu (Reflections on the Motive Power of Fire [1])*,” published in 1824, was not noticed at his time, when his ingenious reasoning of ideal heat engine reversible cycles is not fully recognized, and may be truly comprehended by a few, even now. He gave a full and accurate reasoning of heat engine limitations of “converting heat to work” at the time when caloric theory was flourishing and almost two decades before equivalency between work and heat was experimentally established by Joules in 1843. Sadi Carnot laid ingenious foundations for the Second Law of Thermodynamics before the First Law of energy conservation was known and long before Thermodynamic concepts were established. Sadi Carnot may had not been aware of ingenuity of his

reasoning, and we may have never known since he died at age 36 from cholera epidemic.

In historical context, it is hard to comprehend now how Carnot then ingeniously and fully explained the critical concepts of reversible thermo-mechanical processes and limits of converting heat to work at inception of the heat engines’ era when their efficiency was below 5% and when nature of heat was not fully understood. Confusions about the thermo-mechanical and general Thermodynamic reversibility continued long after Carnot, and even now, after his subtle and ingenious reasoning paved the way to discovery and accurate definition of the Thermodynamic absolute temperature and *entropy*, including entropy conservation during ideal reversible processes and continuous entropy generation during real irreversible processes, as well as establishment of the far-reaching Second Law of Thermodynamics. The Second Law made its appearance after 1850, but a half century later it was already surrounded by so much confusion that the

British Association for the Advancement of Science decided to appoint a special committee with the task of providing clarity about the meaning of this law. However, its final report (Bryan, 1891) did not settle the issue. Half a century later, the physicist/philosopher Bridgman (1941) still complained that “there are almost as many formulations of the Second Law as there have been discussions of it.” And even today, the Second Law remains so obscure, due to the lack of its comprehension, that it continues to attract new efforts at clarification [2, 3], including this one.

The classical, phenomenological Thermodynamics today, almost a forgotten science, has unjustifiably a dubious status. Many modern physicists regard classical Thermodynamics as an obsolete relic. Often, mostly due to lack of subtle comprehension, the Thermodynamics is considered as an engineering subject and thus not as the most fundamental science of energy and nature. However, a number of prominent modern physicists have acknowledged fundamental importance of Thermodynamics. Einstein, whose early writings were related to the Second Law, remained convinced throughout his life that “*Thermodynamics is the only universal physical theory that will never be refuted.*” Many other renowned physicists have been impressed by the universal and indisputable validity of Thermodynamic principles. Apart from the view that Thermodynamics is obsolete, *there is a widespread belief among scientists in Thermodynamics’ absolute authority.* Namely, the phenomenological Laws of Thermodynamics have much wider, including philosophical significance and implication, than their simple expressions based on the experimental observations. “*It is crystal-clear (to me) that all confusions related to the far-reaching fundamental Laws of Thermodynamics, and especially the Second Law, are due to the lack of their genuine and subtle comprehension*” [4-7].

## 2. Sadi Carnot’s Ingenious Reasoning of Ideal Heat Engine Reversible Cycles

Sadi Carnot, at age 28, published in 1824, now famous “*Réflexions sur la puissance motrice du feu (Reflections on the Motive Power of Fire [1]).*” At that time, when the energy conservation law was not known and heat was considered as indestructible caloric, when heat engines were in initial stage of development with efficiency of less than 5%, the

confusion and speculations flourished. Can the efficiency be improved by different temperatures or pressures, a different working substance than water; or some different mode of operation than pistons and cylinders? With ingenious and far-reaching reasoning, Carnot answered all of those questions and proved that maximum, limiting efficiency of heat engine does not depend on medium used in the engine but only depends on (and increases with) the temperature difference between the heat source and cooling medium or heat sink, not directly as, but similarly to the water wheel efficiency dependence on the waterfall height difference (see Fig. 1, formulas are developed after Carnot followers’ work).

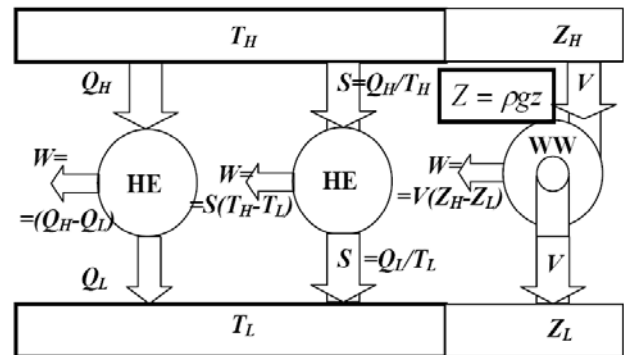

Fig. 1: Similarity between an ideal heat engine (HE) and a water wheel (WW).

The most importantly, Carnot introduced the reversible processes and cycles and, with ingenious reasoning, proved that maximum heat engine efficiency is achieved by any reversible cycle (thus all must have the same efficiency), i.e.:

“*The motive power of heat is independent of the agents employed to realize it; its quantity is fixed solely by the temperatures of the bodies between which is effected, finally, the transfer of the caloric.*” [1], i.e.:

$$W = W_{netOUT} = Q_{IN} \cdot f_c(T_H, T_L)$$

$$\eta_{Ct} = \left. \frac{W_{netOUT}}{Q_{IN}} \right|_{Max} = \left. \underbrace{f_c(T_H, T_L)}_{Qualitative\ function} \right|_{Rev.} \quad (1)$$

Carnot cycle consists of four reversible processes, see Fig. 2: isothermal heating and expansion at constant high-temperature  $T_H$  (process 1-2); adiabatic expansion to archive low-temperature  $T_L$  (process 2-3); isothermal cooling and contraction at constant low-temperature  $T_L$  (process 3-4); and adiabatic

compression to archive high-temperature  $T_H$  and complete the cycle (process 4-1).

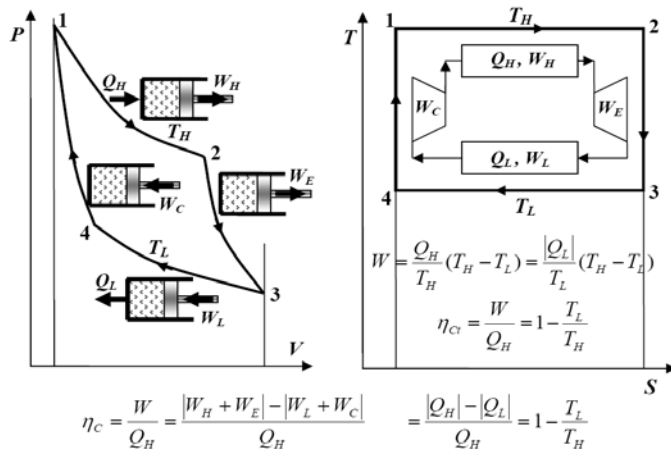

**Fig. 2:** Heat-engine ideal Carnot cycle: note thermal and mechanical expansions and compressions (the former is needed for net-work out, while the latter is needed to provide reversible heat transfer).

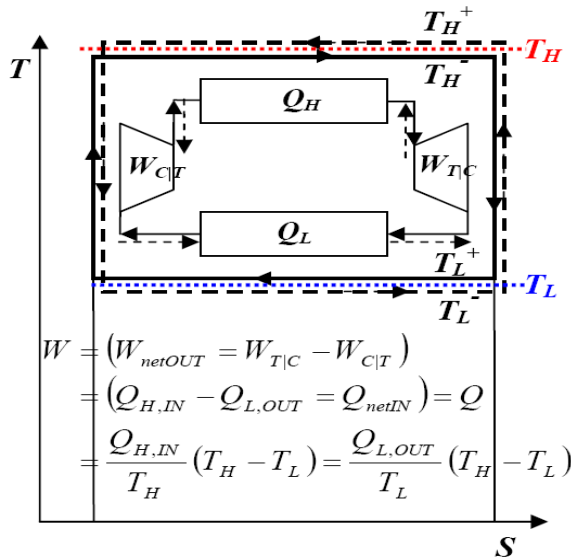

**Fig. 3:** Reversible Heat-engine (solid lines) and Refrigeration Carnot cycle (dashed lines, reversed directions). Note,  $W_H = W_L = 0$  if heat transfer with phase change (compare Fig.2).

All processes are reversible, thus the cycle could be reversed along the same path and with the same quantities of all heat and work in opposite directions (*in-to-out* and vice versa), see Fig. 3, i.e. (note thermal expansion and compression may be replaced by evaporation and condensation during thermal phase changes on Fig. 3):

$$\{Q_H, Q_L, W_C\} \rightleftharpoons \{-Q_H, -Q_L, -W_C\} \quad (2)$$

IF REVERSED

The consequence of the cycle reversibility is the most ingenious and is far-reaching, see Fig. 4 (see also next Section). Let us consider three heat-engine (HE) cycles on Fig. 4: two reversible,  $HE_{R1}$  and  $HE_{R2}$ , and third irreversible,  $HE_{Irr}$ . Let us assume that the cycles are taking place between the same temperature reservoirs (one at higher temperature  $T_H$  and other at lower  $T_L < T_H$ ) and consuming the same quantity of heat  $Q_H$ , but have different efficiencies ( $\eta_{R1} < \eta_{R2} < \eta_{Irr}$ , where  $\eta = W_{netOUT} / Q_H$ ). If we reverse the reversible  $HE_{R1}$  with the smallest efficiency and couple it with either  $HE_{R2}$  or  $HE_{Irr}$  then the net-effect will be production of net-work ( $W_{Irr} - W_{R1} > W_{R2} - W_{R1} > 0$ ) while consuming heat from one thermal reservoir only (at  $T_L$  since  $Q_H$  will be returned back at  $T_H$ ), thus violating the Second Law of Thermodynamics (*perpetual motion machine of the second kind*), see Fig. 4. At the time, Carnot was under impression that the above scenario will be producing work without spending any caloric ( $Q_{L,R2|Irr} = Q_{L,R1} = Q_H$ , thus  $Q_{L,R2|Irr} - Q_{L,R1} = 0$ ) and therefore violating the impossibility of the *perpetual motion machine* (of the first kind; note that neither Thermodynamics nor its Laws were known at that time) [2,3]. Carnot erroneously assumed that the same caloric (heat) will be passing through the engine and produce work by lowering its temperature, similarly to the same water flow passing through the water-wheel and produce work by lowering its elevation potential (see Fig.1). This error, considering the knowledge at the time, in no way diminished the Carnot's ingenious reasoning and conclusions about reversible processes and accurate limitations of heat to work conversion. Alternatively, with similar reasoning as above, if the three heat-engines of Fig. 4 produce the same amount of work  $W_{R1}$ , then the higher efficiency engines will require less heat consumption ( $Q_{H,Irr} < Q_{H,R2} < Q_H$ ), and then the net-effect will be transferring heat ( $Q_{L,R2|Irr} - Q_{L,R1}$ ) from low-to-high temperature reservoirs only (from  $T_L$  to  $T_H$ , without any net-work), again violating the Second Law of Thermodynamics. The above analysis proves that a reversible cycle cannot have smaller efficiency than any other cycle, thus all reversible cycles (we could have reversed either  $HE_{R1}$  or  $HE_{R2}$  but not  $HE_{Irr}$  irreversible one) must have the same maximum possible efficiency for the given temperature of the two thermal reservoirs, independently from anything else, including the nature of heat-engine agent undergoing the cyclic process. Since the irreversible

cycles could not be reversed, they may and do have lower than maximum reversible efficiency up to zero (no net-work produced) or even negative (external work input required to run an inefficient engine that heats), i.e.:

$$\eta_{Irr} < \underbrace{\eta_{Rev} = \eta_{max} = f_C(T_H, T_L)}_{\text{Reversible}} \quad (3)$$

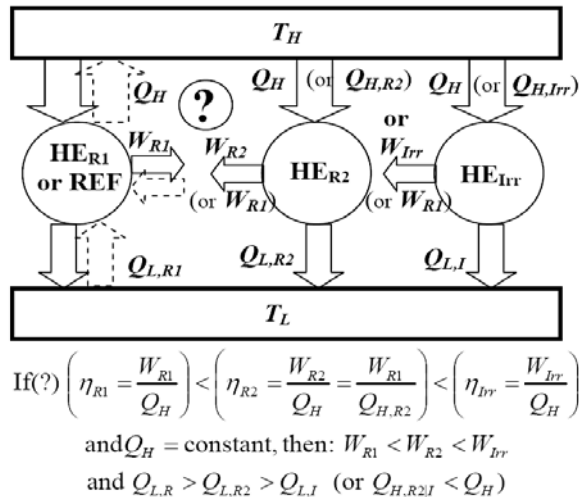

**Fig. 4:** If a reversible heat engine (HE<sub>R1</sub>) has a smaller efficiency than other reversible HE<sub>R2</sub> or irreversible HE<sub>Irr</sub>, then if HE<sub>R1</sub> is reversed (Refrigeration REF cycle) and combined with other HEs, it will result in impossible net-work from a single reservoir ( $W_{R2/I} - W_{R1}$ ), or heat transfer from low to high temperature ( $Q_H - Q_{H,R2/Irr}$ ).

Carnot did not provide quantitative, but qualitative relation for the ideal heat engine efficiency, and accurately specified all conditions that must be satisfied to achieve the maximum efficiency: the need for “re-establishing temperature equilibrium for caloric transfer,” i.e. reversible processes, where heat transfer has to be achieved at negligibly small (in limit zero) temperature difference at both temperature levels,  $T_H$ , high temperature for heat source (heating), and  $T_L$ , low temperature for heat sink (cooling of heat-engine medium), see Fig. 3.

Carnot reasoned that mechanical expansion and compression are needed to decrease and increase the temperature of the engine medium to match the temperature of the high- and low-temperature thermal reservoirs, respectively, and thus provide for the reversible heat transfer (see also [4-6]). Carnot then reasoned that in limiting case a reversible cycle could be reversed using the obtained work and transfer back the caloric (heat) from low- to high-temperature thermal reservoirs, thus laying foundations for the

refrigeration cycles as reversed heat engine cycles, see Fig. 3 and Eq. (2).

Actually, Carnot (1824) established the fundamentals for the second Law of thermodynamics (Clausius 1850, and finalized by Thomson in 1874), before the First Law was even known (Meyer, 1841; Joule, 1843, and finalized by Helmholtz, 1847).

### 3. Thermodynamic Absolute Temperature, Clausius (In)Equality and Entropy, and the Far-Reaching Second-Law of Thermodynamics

**Kelvin Absolute Temperature:** Carnot analyzed critical concepts and qualitative relations related to the “motive-power equivalent of heat” through his ingenious reasoning of reversible cycles, before the Joule’s “mechanical equivalence of heat” was even known. Only after the latter was established it was possible (actually easy) to quantify Carnot engine efficiency, i.e.:

$$\eta_{Ct} = \frac{W_{netOUT}}{Q_{IN}} = \frac{Q_H - Q_L}{Q_H} = 1 - \frac{Q_L}{Q_H} \quad (4)$$

The above Eq. (4) is valid for both, real and ideal, reversible heat engine cycles. However, for reversible Carnot cycles the efficiency depends only on the temperature values of the two heat reservoirs (Eq. 1). Furthermore, more specific relation for the Carnot efficiency could be inferred by considering the three related Carnot cycles on Fig. 5. For a given  $T_H$ , for arbitrary high-temperature reservoir and given arbitrary low  $T_{Ref}$ , for reference-temperature reservoir, the combined Carnot efficiency of the two heat engines, HE<sub>HT</sub> and HE<sub>TR</sub>, cascaded at an arbitrary intermediate temperature level  $T$ , must be the same as the corresponding Carnot efficiency of a third heat engine HE<sub>HR</sub>, running between the two temperature reservoirs with the same heat input  $Q_H$ , and thus releasing the same heat  $Q_{Ref}$ , at a given reference temperature  $T_{Ref}$ , see Fig. 5. Thus for everything, but intermediate temperature  $T$ , given as fixed quantities, the heat  $Q(T)$  transferred from HE<sub>HT</sub> to HE<sub>TR</sub> engine must be directly proportional to  $Q_{Ref}$  (efficiency is an intensive HE property) and a non-negative and increasing function of  $T$  only, i.e.:

$$Q(T) = Q_{Ref} \cdot f(T, T_{Ref}) \Big|_{T_{Ref}=given} = Q_{Ref} \cdot f(T) \quad (5)$$

Then, the above could be applied for any temperature level, say  $T=T_1$  or  $T=T_2$  or  $T=T_H$ , and very important correlation deduced:

$$\frac{Q(T_1)}{Q(T_2)} = \frac{Q_{Ref} \cdot f(T_1)}{Q_{Ref} \cdot f(T_2)} = \frac{f(T_1)}{f(T_2)} \Big|_{f(T)=\theta=T} = \frac{T_1}{T_2} = \frac{Q_1}{Q_2} \quad (6)$$

The above function  $f(T)$  could be any arbitrary, but *non-negative* and *increasing* function of temperature, thus defining a new *absolute Thermodynamic temperature scale*, say  $\theta=T$ , independent of the substance of a thermometer.

The above function, the Carnot ratio equality (Eq. 6), is much more important than what it appears at first. Actually it is probably the most important equation in Thermodynamics and among the most important equations in natural sciences.

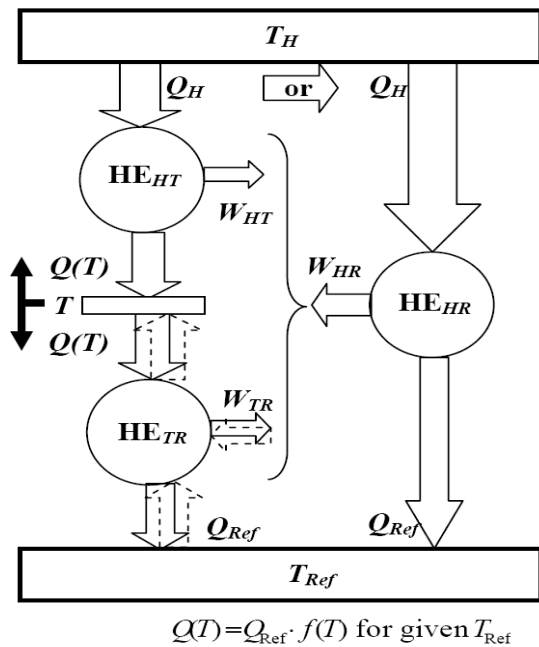

**Fig. 5:** For a fixed  $T_H$ ,  $T_{Ref}$ ,  $Q_H$ , and  $Q_{Ref}$ , the  $Q(T)$  is proportional to  $Q_{Ref}$  (efficiency is intensive property) and an increasing function of  $T$  for a given  $T_{Ref}$ .

Not only that Eq. (6) defines the Thermodynamic absolute temperature scale, which is independent of the substance of a thermometer, but it will define a fundamental property of matter, the entropy  $S$ , the related process-equilibrium functions and correlations, and quantify irreversibility (loss of work potential), and the far-reaching Second Law of Thermodynamics.

In some references the Carnot ratio equality of heat and related absolute temperature functions, is deduced from the following reasoning, see Fig. 5 again (If  $T=T_T$ , then  $Q(T)=Q_T$ ):

$$\begin{aligned} \left(\frac{Q_{Ref}}{Q_H}\right) &= \underbrace{1 - f_C(T_H, T_{Ref})}_{\text{Not function of } T} = \left(\frac{Q_T}{Q_H}\right) \cdot \left(\frac{Q_{Ref}}{Q_T}\right) \\ &= \underbrace{f_{C1}(T_H, T_T)}_{\text{Dependence of } T \text{ must cancel}} \cdot \underbrace{f_{C1}(T_T, T_{Ref})}_{\text{must be}} \\ &= \left(\frac{f(T_T)}{f(T_H)}\right) \cdot \left(\frac{f(T_{Ref})}{f(T_T)}\right) = \left(\frac{f(T_{Ref})}{f(T_H)}\right) = \left(\frac{Q_{Ref}}{Q_H}\right) \quad (7) \end{aligned}$$

Now, it is easy to write the correlation to define a linear absolute temperature scale for a given arbitrary reference temperature and unit increment, say  $T_{Ref}=273.15\text{ K}$  and unit of absolute temperature  $1\text{ K} = 1^\circ\text{C}$  (Kelvin, 1848), i.e.:

$$\frac{T}{T_{Ref}} = \frac{Q(T)}{Q(T_{Ref})} = \frac{Q(T)}{Q_{Ref}} \quad \text{or} \quad T = \frac{Q(T)}{Q(T_{Ref})} T_{Ref} = \frac{Q(T)}{Q_{Ref}} T_{Ref} \quad (8)$$

Where,  $Q$  and  $Q_{Ref}$ , are heat transferred in any reversible Carnot cycle working between an arbitrary temperature  $T$  and the reference temperature  $T_{Ref}$ .

**Clausius Equality (Entropy) and Inequality:**

Another important consequence of the Carnot ratio equality, Eq. (6), for a Carnot cycle working between the two constant temperature thermal-reservoirs,  $T=T_H$  or  $T=T_L$ , is:

$$\frac{Q_{H,IN}}{T_H} - \frac{Q_{L,OUT}}{T_L} = \frac{Q(T_H)}{T_H} + \frac{Q(T_L)}{T_L} = 0; \quad (9)$$

where  $Q(T) = Q_{IN} = -Q_{OUT}$

Or in general, for a variable temperature, reversible Carnot Cycle working between arbitrary variable temperature thermal-reservoirs, see Fig. 6, and after integration of Eq. (9) for infinitely many Carnot cycles of infinitesimally small heat transfer  $\delta Q$  at virtually constant temperature  $T$ , we have:

$$\begin{aligned} \int_A^B \left( \frac{\delta Q_{H,IN}}{T_H} - \frac{\delta Q_{L,OUT}}{T_L} \right) &= \oint \left( \frac{\delta Q(T_H)}{T_H} + \frac{\delta Q(T_L)}{T_L} \right) \\ &= \oint \frac{\delta Q(T)}{T} = 0 \quad (10) \\ &\quad \underbrace{\hspace{10em}}_{\text{Rev. Cycle Clausius Equality}} \end{aligned}$$

This is well-known Clausius equality (more about Clausius inequality later), which defines new fundamental property entropy, since it is independent on process path  $Q(T)$ , namely (compare with Eq. 10):

$$\oint_{\text{Cycle}} \frac{\delta Q}{T} = \int_A^B \frac{\delta Q(T_H = T_{\text{any}})}{T_H} \Big|_{\text{Rev}} + \int_B^A \frac{\delta Q(T_L, \text{as given})}{T_H} \Big|_{\text{Rev}} = 0 \quad (11)$$

Any Rev. Path
Fixed Pat

$$S_A - S_B = \int_A^B \frac{\delta Q(T_H = T_{\text{any}})}{T_H} \Big|_{\text{Rev}} = \int_A^B \frac{\delta Q(T_L, \text{as given})}{T_H} \Big|_{\text{Rev}}$$

Any Rev. Path
Fixed Path

$$= \text{const} \quad (\text{independent of path } Q(T = T_{\text{any}}))$$

Thus System Property

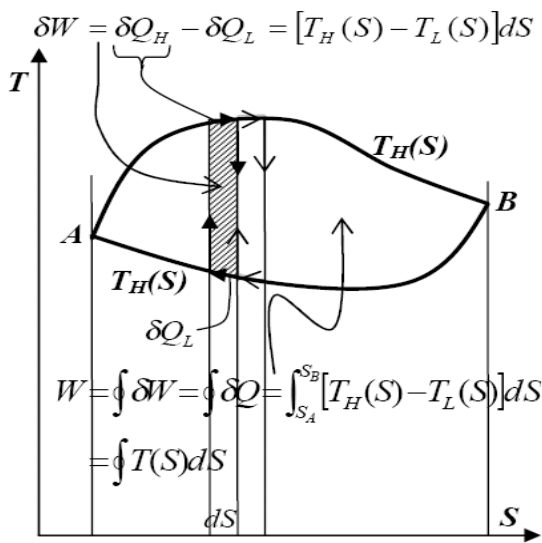

**Fig. 6:** Clausius equality: Variable temperature reservoirs require multi-stage Carnot cycles

For real, irreversible cycles, the heat engine efficiency is smaller than for reversible cycles, i.e., for everything else being the same  $W_{Irr} \leq W_{Rev}$  (equality in limit if irreversibility reduces to reversibility). Then we can reason the proof of the famous Clausius inequality as follow:

$$(W_{Irr} = \oint \delta Q_{Irr}) \leq (\oint \delta Q_{Rev} = W_{Rev}) \quad (12)$$

$$\oint \frac{dQ}{T} \Big|_{Irr} \leq \underbrace{\left( \oint \frac{dQ}{T} \Big|_{Rev} = 0 \right)}_{\text{Eq. (10)}} \text{ or } \underbrace{\oint \frac{dQ}{T}}_{\text{Any Cycle Clausius Inequality}} = -S_{Gen} \leq 0 \quad (13)$$

The second Law of Thermodynamics is formulated based on the definition of entropy (Eq. 11) and the Clausius inequality (Eq. 13), the latter defines the entropy generation,  $S_{Gen} \geq 0$  due to irreversibility (note  $\Delta S_{\text{Cycle}} \equiv 0$ , but  $S_{Gen} \geq 0$  due to cycle irreversibility if any; the generated entropy is transferred to all affected surrounding systems).

#### 4. Additional Reasoning of the Carnot Work Equivalency of Heat

Joule’s experiments have proved the equivalency of fully irreversible conversion of mechanical work to heat or more accurately via generated heat into the internal thermal energy (of a single thermal reservoir). However, the Joule’s “*mechanical equivalent of heat*” does not work in reverse for thermal energy (or heat) conversion to mechanical energy (or work), since it is not possible to reverse original, fully-irreversible Joule’s process and convert heat (thermal energy) from a single reservoir to work without any other impact with the surroundings (i.e., spontaneously). Here the Carnot principle provides the missing “heat equivalent of work” or “*Carnot motive-power equivalent of heat*” via reversible heat-engine conversion of thermal energy into mechanical work. In order to extract work from a heat reservoir, it is necessary to employ a heat engine running a power cycle, while transferring part of the heat from a high-temperature reservoir to a low-temperature reservoir, that is, it is necessary to have, in addition to high-temperature reservoir for heating, also a low-temperature reservoir to cool a part of the heat-engine cycle. Without the low-temperature reservoir to provide thermal compression by cooling of a gas (or condensation of a vapor during cycle isothermal heat removal), all obtained expansion work (or even more in non-ideal cycle) will be needed to compress the cycle medium to the original temperature, and all absorbed heat (or even more in non-ideal cycle) has to be removed out from the cyclic medium in order to complete the cycle, see Fig. 7 (right). Therefore, the so called “waste cooling-heat” in power cycles (like in thermal power plants) is not waste but very useful heat, necessary for thermal compression of cycling medium (steam-into-condensate, for example), without which it will not be possible to produce mechanical work from heat (i.e., thermal energy).

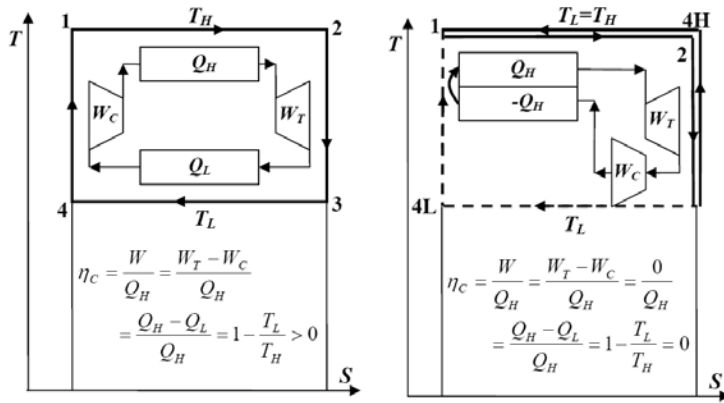

**Fig. 7:** Heat engine ideal *Carnot* cycle between two different temperature heat-reservoirs ( $T_H > T_L$  and  $W > 0$ ) (**left**), and with a single temperature heat-reservoirs ( $T_H = T_L$  and  $W = 0$ , ideal reversible cycle) (**right**). Low-temperature thermal compression is needed (critical), not the mechanical (isentropic) compression, to realize work potential between the two different temperature heat-reservoirs, due to internal thermal energy transfer via heat ( $W = Q_H - Q_L > 0$ ). The isentropic expansion and compression are needed to provide temperature for reversible heat transfer, while net thermal expansion-compression provides for the net-work out of the cycle.

Thermal and mechanical energy and their energy-potentials, temperature and pressure, are interrelated (coupled). Reversible addition of work (mechanical compression) or heat (heating via thermal energy transfer), or irreversible heating (via loss of work or work potential) will increase simultaneously pressure (mechanical elastic energy potential) and temperature (thermal energy potential), and vice versa. The reversible Carnot cycle is the “gauge tool” to uncouple the mechanical energy from thermal energy and thus establish their equivalency. If we heat a gas in a piston its internal energy will increase, and mechanical work potential with regard to other reference thermal reservoir is expressed with Carnot efficiency (only if non-equilibrium exist, otherwise no work potential). The cyclic process is ideal method to decouple and measure the mechanical power-equivalent of the thermal energy. It is accomplished by an intermediary system, which after making the whole reversible cycle (or integer number of cycles, thus coming to the same final state as initial), it will not make any change of volume or any other property to itself. There will be thermal and mechanical expansions and compressions (or thermal evaporation and condensation if change of phase). The net work is due to the net-thermal expansion-compression, since the net-mechanical expansion-compression is zero without phase change for any reversible cycle exposed to thermal reservoirs only

(see ideal gas Carnot cycle elsewhere [6]). However the mechanical expansion-and-compression are needed to adjust temperature for reversible heat transfer at virtually zero temperature difference. Such reversible cycle, in limit, will run spontaneously when transferring heat from high to low temperature reservoirs and extract maximum work possible. If the cycle is reversed by using the obtained work, it will transfer the same heat in reverse, from low to high temperature, thus performing a reversible refrigeration (or heat pump) cycle, to be elaborated elsewhere [6].

## 5. Conclusion

Carnot ingenious reasoning (in 1824), at the time when little was known about heat and work interactions, much before establishment of the “*mechanical equivalent of heat*” (Joule, 1843), helped his followers to extend his work and to define absolute Thermodynamic temperature (Kelvin, 1848) and *entropy*, a new Thermodynamic material property (Clausius, 1850, Boltzman, 1880), as well as the Gibbs free energy (Gibbs 1878), one of the most important Thermodynamic functions for the characterization of electro-chemical systems and processes, like the voltage outcomes of an electrochemical cell, and the equilibrium constant for a reversible chemical reaction. The Carnot work, almost unnoticed at his time and not enough recognized even now, has had unprecedented and far-reaching consequences, and was crucial for development of new science of Thermodynamics. Carnot answered many questions related to the equivalency of “*motive power*” and “*heat*” through his ingenious reasoning of reversible cycles.

*Carnot reasoning opened the way to generalization of Thermodynamic reversibility and energy process equivalency (conserving non-equilibrium using reversible processes), definition of absolute Thermodynamic temperature and a new Thermodynamic material property “entropy,” as well as the Gibbs free energy, one of the most important Thermodynamic functions for the characterization of electro-chemical systems and their equilibriums, thus resulting in formulation of the universal and far-reaching Second Law of Thermodynamics, see Fig. 8:*



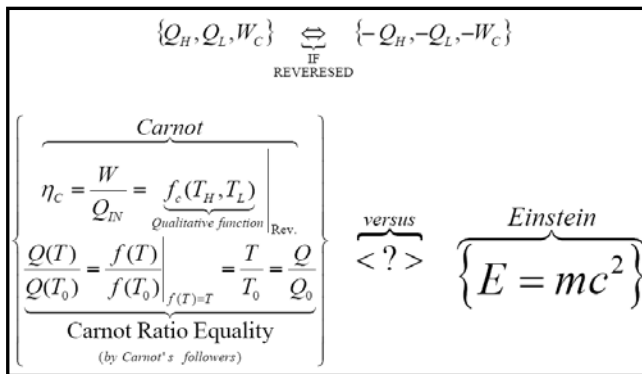

**Fig. 8:** Significance of the Carnot's reasoning of reversible cycles is in many ways comparable with the Einstein's relativity theory in modern times. The *Carnot Ratio Equality* is much more important than what it appears at first. It is probably the most important equation in Thermodynamics and among the most important equations in natural sciences.

In conclusion, it is only possible to produce work during energy exchange between systems in non-equilibrium, not within a single thermal reservoir in equilibrium, for example. Actually, the work potential is measure of the systems' non-equilibrium, thus the work potential could be conserved only in processes if the non-equilibrium is preserved (conserved, i.e. rearranged – cycle work has to be stored eventually), and such ideal processes could be reversed, and thus named reversible processes. When systems come to the equilibrium there is no potential for any process to produce (extract) work. Therefore, it is impossible to produce work from a single thermal reservoir in equilibrium: otherwise, non-equilibrium will be spontaneously created leading to a “black-hole-like energy singularity,” instead to the equilibrium with randomized equi-partition of energy at particulate level. It is only possible to produce work from thermal energy in a process between two thermal reservoirs in non-equilibrium (with different temperatures). Consequently, if heat transfer takes place spontaneously at finite temperature difference, without possible reversible Carnot work extraction, the latter work potential will be permanently “lost,” thus irreversibly dissipated into thermal energy. Maximum work, for a given heat transfer from high to low temperature thermal reservoirs, will be produced during ideal, reversible Carnot cyclic process, in order to prevent any other impact to the surrounding, (like net-volume expansion, etc.; net-cyclic change is zero). All real natural processes between systems in non-equilibrium have tendency towards common equilibrium and thus loss of the original work potential, by converting (“dissipating”)

other energy forms into the thermal energy accompanied with increase of entropy (randomized equi-partition of energy per absolute temperature level). Due to loss of work potential in a real process, the resulting reduced work cannot reverse back the process to the original non-equilibrium, as is possible with ideal reversible processes. Since non-equilibrium cannot be created or increased spontaneously (by itself and without interaction with the rest of the surroundings) then all reversible processes must be the most and equally efficient (will equally conserve work potential, i.e. conserve non-equilibrium, otherwise will create non-equilibrium by coupling with differently efficient reversible processes). The irreversible processes will loose work potential to thermal energy with increase of entropy, thus will be less efficient than corresponding reversible processes as is stated in Eq. (12) and further elaborated and generalized elsewhere [6].

## References:

1. Sadi Carnot, *Reflections on the Motive Power of Heat*, English translation by R.H. Thurston (1824) <http://www.thermohistory.com/carnot.pdf> or <http://www.history.rochester.edu/steam/carnot/1943/>
2. J. Uffink, *Bluff your way in the second law of thermodynamics*, Studies in History and Philosophy of Modern Physics, 32(3), 305-394 (2001) <http://philsci-archive.pitt.edu/archive/00000313/>
3. E.T. Jaynes, *The evolution of Carnot's principle*, in G. J. Erickson and C. R. Smith (eds.) *Maximum-Entropy and Bayesian Methods in Science and Engineering* vol. 1, p. 267 (1988). <http://bayes.wustl.edu/etj/articles/ccarnot.pdf>
4. Kostic, M., *Irreversibility and Reversible Heat Transfer: The Quest and Nature of Energy and Entropy*, IMECE2004, ASME Proceedings, ASME, New York, 2004. <http://www.kostic.niu.edu/Kostic-Energy-Entropy-Irreversibility.pdf>
5. Kostic, M., *Physics of Energy*, In *Encyclopedia of Energy Engineering and Technology* (B. L. Capehart, Editor), Taylor & Francis/CRC Press, 2007. [http://www.kostic.niu.edu/Energy\\_Physics-Kostic.pdf](http://www.kostic.niu.edu/Energy_Physics-Kostic.pdf)
6. Kostic, M., *Treatise with Reasoning Proof of the Second Law of Energy Degradation*, Manuscript, Northern Illinois University, 2006-2008. <http://www.kostic.niu.edu/Kostic-2nd-Law-Proof.pdf>
7. Kostic, M., *Treatise with Reasoning Proof of the First Law of Energy Conservation*, Manuscript, Northern Illinois University, 2006-2008. <http://www.kostic.niu.edu/Kostic-1st-Law-Proof.pdf>