

# Effect of Harmonic Power Fluctuation on Voltage Flicker

JIN-LUNG GUAN<sup>1</sup>, MING-TA YANG<sup>2</sup>, JHY-CHERNG GU<sup>3</sup>, HSIN-HUNG CHANG<sup>1</sup>

Department of Electrical Engineering

Hwa Hsia Institute of Technology<sup>1</sup> St. John's University<sup>2</sup>

National Taiwan University of Science and Technology<sup>3</sup>

Taipei

TAIWAN

<http://www.hwh.edu.tw>

*Abstract:* Voltage flicker problems have long existed in several of the distribution areas served by the Taiwan Power Company. In the past, those research results indicating that the estimated  $\Delta V_{10}$  value based on the conventional method is significantly smaller than the survey value. This paper is used to study the relationship between the voltage flicker problems and harmonic power variation for the power system with electric arc furnaces. This investigation discussed thought the effect of harmonic power fluctuation with flicker estimate value. The method of field measurement, statistics and simulation is used. The survey results demonstrate that  $\Delta V_{10}$  estimate must account for the effect of harmonic power variation.

*Key-Words:* - Voltage Flicker, Harmonic, EAF,  $\Delta V_{10}$

## 1 Introduction

Voltage flicker is mainly caused by rapid change of loads in power systems, such as electric arc furnaces (EAF). During the operation of an EAF, the electric poles short circuit and an enormously unstable current is produced, causing current flow to change significantly, and in turn causing serious voltage flickers that influences neighboring power consumers. According to IEEE Std-100, voltage flicker is luminosity variation or an image disruption caused by lower frequency voltage fluctuations [1].

Power systems currently face serious problems arising from voltage flicker, which is an important threat to power quality [2], and is currently being targeted by the aggressive power supply quality improvement efforts of the Taiwan Power Company (TPC). Presently, the major source of flicker is the EAF used in steel making plants. Voltage flicker associated with an EAF is evaluated in two main ways around the world. The first is flicker meter, which is the IEC standard and has been established by the UIE [3]. The other is  $\Delta V_{10}$  meter, which is established by the Japanese Technical Committee [4].

Voltage flicker causes sudden flashes of luminosity in fluorescent lamps and electric lights, and consequent eye discomfort, while noticeable, persistent and long-term flicker causes eye tiredness and vision problems. Unstable lighting is thus the most frequent voltage flicker related complain of power consumers. In the case of TV sets, the size of the screen image changes with the intensity of the flicker, while other instances precision electronic equipment also suffers a certain degrees of negative influence from voltage flickers [5], [6]. Voltage flicker problems have long existed in many of the distribution areas served by TPC, especially those that include steel plants that operate arc furnaces [7]-[9]. When EAF is operating after installation, the power company and steel manufacturers must evaluate the influences of EAF on power systems. Before installing the EAF, capacities of improving facilities related to voltage flicker must be calculated and estimated. Owing to load variation of EAF during steel manufacture being quite violent, the non-linear phenomenon obviously follows the melt degree of scrap iron. On estimating the severity of voltage flicker, part circuits and load parameters were often ignored and assumed owing to an inability to

obtain the true parameters. However, steel factories still experience serious voltage flicker problems even flicker improving facilities has been installed, and thus Guan [10], [11] probes into the differences between the estimated  $\Delta V_{10}$  and the survey value of actual EAF operations. This investigation will discuss the relationship between voltage flicker and harmonic power fluctuation for EAF. The flicker phenomenon that the EAF operation causes can apply a reactive power compensation to give an improvement effectively, but if harmonic improvement not appropriate and cause the harmonic resonance enlarge may confuse voltage flicker phenomenon. Hence, in this thesis the effects of harmonic power fluctuation to voltage flicker will be intensively surveyed.

## 2 Harmonic Power and Voltage Flicker

Presently, two methods of measuring and estimating the degree of voltage flicker exist, namely Short Term Severity ( $P_{st}$ ) and 10Hz equivalent value ( $\Delta V_{10}$ ). They all conveniently explain the severity of voltage flicker survey values and control bases. Central Research Institute of the Electric Power Industry [4] of Japanese suggested the use of the  $\Delta V_{10}$  as the standard for evaluating voltage flicker. Moreover,  $\Delta V_{10}$  is the method presently used by TPC, and thus is applied herein. Meanwhile, an amplitude modulation formula can approximate voltage flicker as represented by eq. (1)[12].

$$V(t) = \sqrt{2}V_{rms} \left[ 1 + \frac{1}{2} \sum_n \Delta V_n \cdot \cos(2\pi \cdot f_n \cdot t + \phi_n) \right] \cos(2\pi \cdot 60 \cdot t) \quad (1)$$

where  $f_n$  : modulation frequency n Hz of flicker  
 $\phi_n$  : modulation phase angle of flicker  
 $\Delta V_n$  : voltage fluctuation of frequency n Hz.  
 $V_{rms}$  : voltage effective value of 60 Hz

The Fast Fourier Transform (FFT) approach can be used to calculate the frequency spectrum of voltage flicker. Generally, only the frequency range within 0.1 Hz to 30 Hz was considered, and in higher frequency ranges, human eyes are not as sensitive owing to residual vision. Based on eq. (2),  $\Delta V_{10}$  is obtained from

$$\Delta V_{10} = \sqrt{\sum_n (a_n \times \Delta V_n)^2} \quad (2)$$

where  $a_n$  : visual sensitivity coefficient of frequency n Hz

In addition to the fundamental frequency with 60 Hz, still contain the frequency multiplication composition of many fundamental frequencies be called harmonic, the nonlinear component (as the transformer) in the power system and burden (as adapter), will cause harmonic effect. According to the Fourier Transform analysis, voltage and current of any periodic can combine to, as follows.

$$f(t) = a_0 + \sum_{n=1}^{\infty} (a_n \cos n\omega_0 t + b_n \sin n\omega_0 t) \quad (3)$$

where  $a_0 = \frac{1}{T} \int_{-T/2}^{T/2} f(t) dt$   
 $a_n = \frac{2}{T} \int_{-T/2}^{T/2} f(t) \cos n\omega_0 t dt$   
 $b_n = \frac{2}{T} \int_{-T/2}^{T/2} f(t) \sin n\omega_0 t dt$

The criteria presently used to estimate the severity of EAF voltage flicker involve the maximum reactive power fluctuation method (MRPFM) [4]. The voltage fluctuation ( $\Delta V$ ) and reactive power fluctuation ( $\Delta Q$ ) are calculated using the equation of  $|\Delta V| \cong X_s \Delta Q$  at the point of common coupling (PCC). The variation in the load on EAF during steel manufacture is quite violent, so the melting of scrap iron is clearly non-linear. In estimating the severity of voltage flicker, part of line and load parameters are often ignored since the true parameters hard to obtain. However, the method suffers a severe disadvantage in that the estimated  $\Delta V_{10}$  is smaller than the surveyed value. The survey results demonstrate that significant variations in active power and reactive power are very alike. Furthermore, the  $\Delta V_{10}$  estimate cannot ignore the effect of active power variation [10]. At this time,  $\Delta V$  and  $\Delta S$  are calculated using  $|\Delta V| \cong X_s \Delta S$ . Meanwhile,  $\Delta S$  is calculated using the equation of  $\sqrt{\Delta P^2 + \Delta Q^2}$ .

Usually, the EAF factories are widespread to install filter equipment and the harmonic power will be small. Meanwhile, the estimated  $\Delta V_{10}$  value obtained using the conventional method and the harmonic power always neglected. Restated, the significant harmonic power variation of EAF will become an important cause of voltage flicker if the system resonance takes place. That is to say, the  $\Delta V_{10}$  estimate cannot ignore the effect of harmonic power fluctuation.

This paper defines apparent power as eq. (4), Meanwhile, D is the distortion power,  $P_1$  is the active power of 60 Hz, and  $Q_1$  is the reactive power of 60 Hz. The distortion power D can be represented

by eq. (5). Figure 1 presents the 3D vector diagram of the apparent power.

$$S = \sqrt{P_1^2 + Q_1^2 + D^2} \tag{4}$$

$$D = \sqrt{\sum D_n^2} \tag{5}$$

$$D_n = V_n \cdot I_n^*, \quad n \neq 1$$

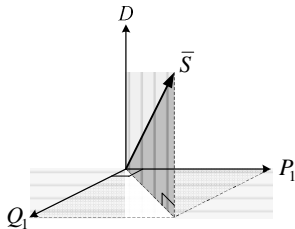

Fig. 1. The 3D vector diagram of the apparent power

However, this study proposes a revisable method that can yield more accurate  $\Delta V_{10}$  estimate than the conventional method. Now, the voltage fluctuation ( $\Delta V$ ) and apparent power fluctuation ( $\Delta S$ ) are calculated using the equation of  $|\Delta V| \cong X_s \Delta S$ . Where  $\Delta S$  is modified using the equation of  $\sqrt{\Delta P^2 + \Delta Q^2 + \Delta D^2}$ .

### 3 Simulation of System for Harmonic and Flicker

Figure 2 displays the instantaneous voltage and current waveforms of a second. Make use of injection harmonic current, measure the voltage and current on service entrance point. Meanwhile, the results show as figure 3, respectively. Obviously, the harmonic amplification really causes the evident fluctuation of voltage and current. It was quite distorted, clearly differing between two fig. 2 and fig. 3. Apparently, the harmonic phenomenon is enlarged when capacitor plug-in the power system, causing severe voltage flicker.

The relation of harmonic power D and voltage flicker  $\Delta V_{10}$  value is analyzed by using Matlab/Simulink. Figure 4 shows the single-line diagram of actual power system. Furthermore, the Matlab/Simulink is used to create the imitate circuit of actual EAF power system. The harmonic source of imitation shows on Orange Square of figure 5. Data are sampled during the stage of filter cut-off period because the harmonic current of EAF load is reserved whole at this time. Factory A1 and D1 are selected as example, while table 1 and 2 show the

survey results of actual harmonic currents of 1~20 time on the primary side of a Furnace Transformer (FT). Meanwhile, the survey results will be the harmonic current source of simulation.

From the simulation results, the current harmonics of factory D1 had slight enlarge when capacitor plug-in the system EAF. However, the factory A1 didn't take place the amplification phenomenon of the harmonic. Further, observe the relativity between the harmonic power D and voltage flicker  $\Delta V_{10}$  value. When EAF is simulated operated after capacitor plug-in and harmonic currents of 1~20 time infuse-into the system, measure the primary side of FT of factory A1.

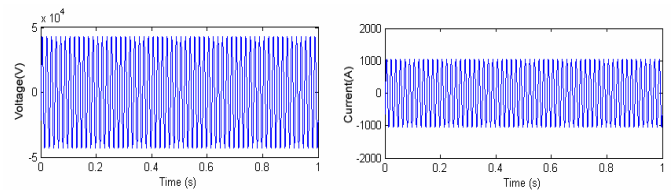

Fig. 2. Imitate instantaneous waveform without capacitor plug-in system

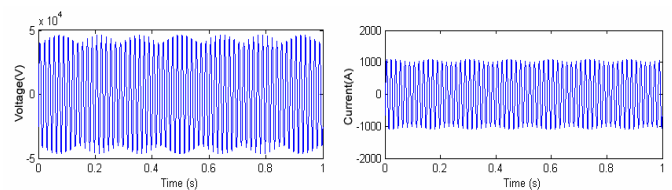

Fig. 3. Imitate instantaneous waveform with capacitor plug-in system

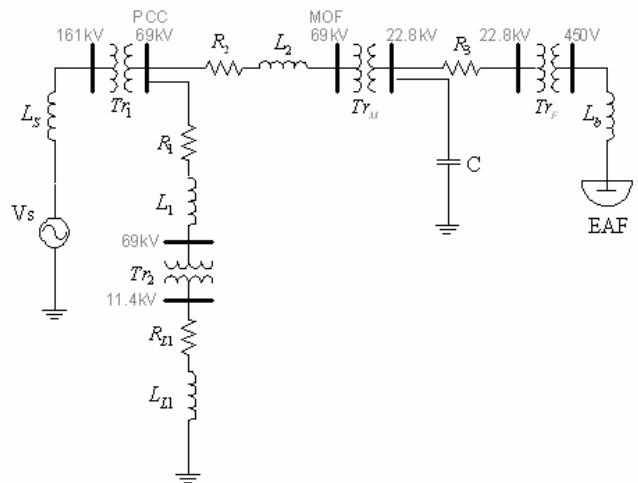

Fig. 4. Single-line diagram of the actual power system

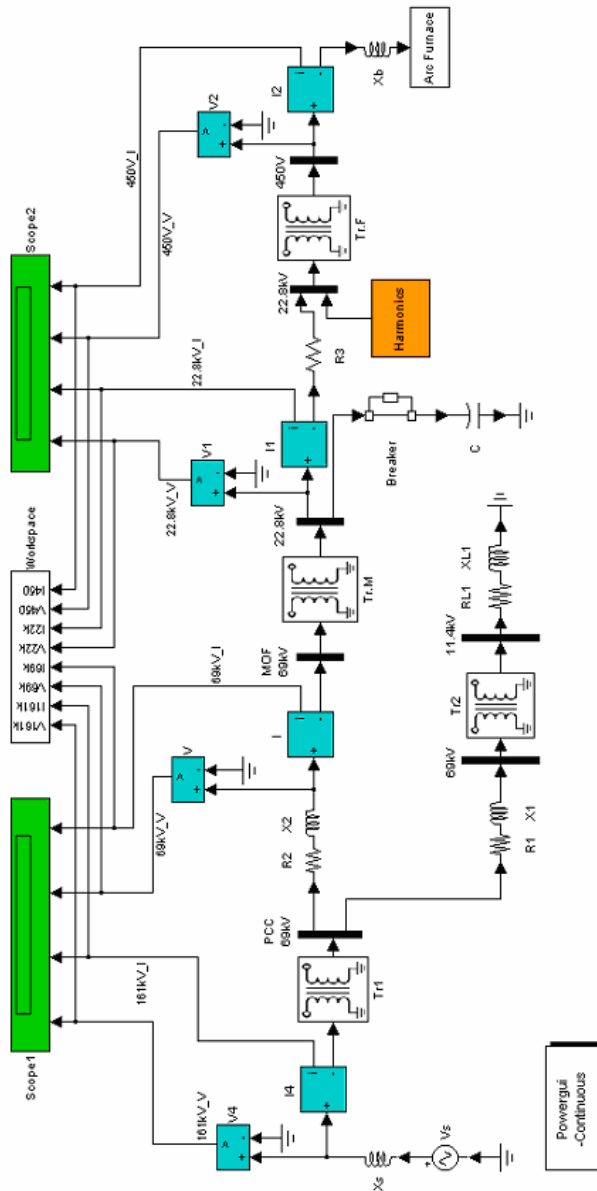

Fig. 5. Square diagram of the imitate power system

Table 1. Field harmonic currents measurement results of FT of factory A1

$I_1(\%)$	$I_2(\%)$	$I_3(\%)$	$I_4(\%)$	$I_5(\%)$	$I_6(\%)$	$I_7(\%)$	$I_8(\%)$	$I_9(\%)$	$I_{10}(\%)$
100	16.63	10.69	6.18	3.41	2.26	2.56	1.46	1.29	1.10
$I_{11}(\%)$	$I_{12}(\%)$	$I_{13}(\%)$	$I_{14}(\%)$	$I_{15}(\%)$	$I_{16}(\%)$	$I_{17}(\%)$	$I_{18}(\%)$	$I_{19}(\%)$	$I_{20}(\%)$
1.00	0.81	0.80	0.71	0.66	0.60	0.56	0.50	0.44	0.36

Table 2. Field harmonic currents measurement results of FT of factory D1

$I_1(\%)$	$I_2(\%)$	$I_3(\%)$	$I_4(\%)$	$I_5(\%)$	$I_6(\%)$	$I_7(\%)$	$I_8(\%)$	$I_9(\%)$	$I_{10}(\%)$
100	0.06	0.32	0.17	0.37	0.22	0.50	0.28	0.51	0.33
$I_{11}(\%)$	$I_{12}(\%)$	$I_{13}(\%)$	$I_{14}(\%)$	$I_{15}(\%)$	$I_{16}(\%)$	$I_{17}(\%)$	$I_{18}(\%)$	$I_{19}(\%)$	$I_{20}(\%)$
0.54	0.35	0.61	0.29	0.53	0.34	0.94	0.31	0.48	0.28

Figure 6 shows the frequency spectrums of current of factory A1. The simulate results indicate that the harmonics of factory A1 have no enlarge phenomenon. Meanwhile, simulation process of D1 is Similar to A1. Figure 7 shows the frequency spectrums of current of factory D1. The simulate results clearly indicate that the harmonics of factory D1 have enlarge phenomenon. From the simulate results of the figure 6 and 7, can discover more obvious variation amplitude of harmonic power D that lead to an severe voltage flicker. That is to say, the voltage flicker  $\Delta V_{10}$  value must account for the influence of harmonic power variation.

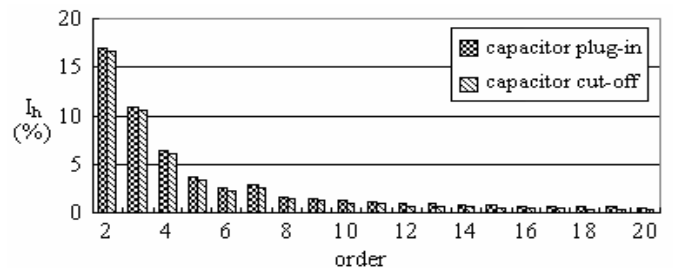

Fig. 6. Simulation frequency spectrums of current on the primary side of FT of factory A1

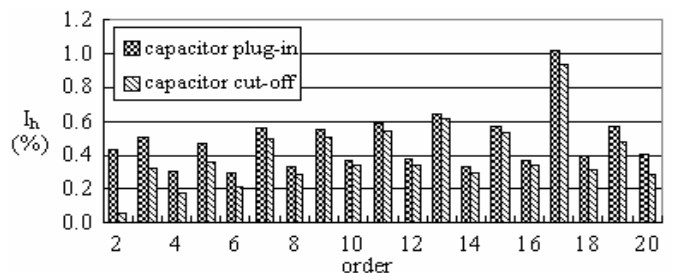

Fig. 7. Simulation frequency spectrums of current on the primary side of FT of factory D1

The visual sensitivity coefficient  $a_n$  is a function of flicker frequency that describes the visibility of illumination flicker to the human eye-brain mechanism. When the frequency is below 0.1Hz or above 30 Hz, the sensitivity coefficients are so small that they can be ignored. Now, imitating the harmonic of system has two condition that is harmonic enlarge and not enlarge. Meanwhile, take the power data of the service entrance point of EAF factory to calculate the harmonic power fluctuation. Fig. 8 and Fig. 9 show the imitate frequency spectrums of harmonic power fluctuation. When system occur harmonic enlarge, also clearly indicting that harmonic enlargement in addition to let harmonic power D value rising, also the harmonic power fluctuation enlargement.

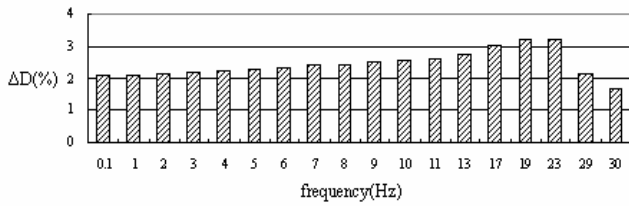

Fig. 8. Frequency spectrums of harmonic power fluctuation  $\Delta D$  with harmonic power enlargement of the system

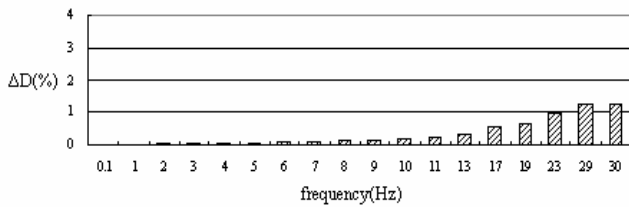

Fig. 9. Frequency spectrums of harmonic power fluctuation  $\Delta D$  without harmonic power enlargement of the system

### 4 Analysis Of EAF Load

This investigation discusses and analyses the EAF load characteristics, such as  $V$ ,  $I$ ,  $P$ ,  $Q$ ,  $S$ ,  $\Delta V_{10}$  and  $D$ , for three 69kV ac (namely A1, A2 and A3) and a 161kV dc (namely D1) EAFs by using a field survey. Figure 10 shows the points of the field survey. Using the continuous model, data are obtained at a rate of one sample per minute. Data are sampled during the period from 22:00 to 08:00 the next-day because the steel factory operates only during off-peak hours. The measurement time takes 5-7 days as a principle. This investigation conducts a statistical analysis of survey data. This investigation conducts a statistical analysis of survey data. The data with the 97.5% and 2.5% cumulative probabilities represent the maximum and minimum values, respectively.

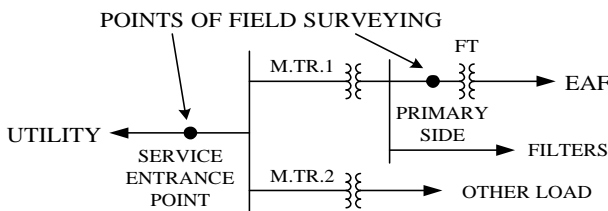

Fig. 10. Single-line diagram of the steel factory

Factories A1 and D1 are chosen as examples, while Figs. 11 and 12 show the survey results of  $P$ ,  $Q$ ,  $D$  and  $\Delta V_{10}$  at the service entrance point of factory A1 and D1.

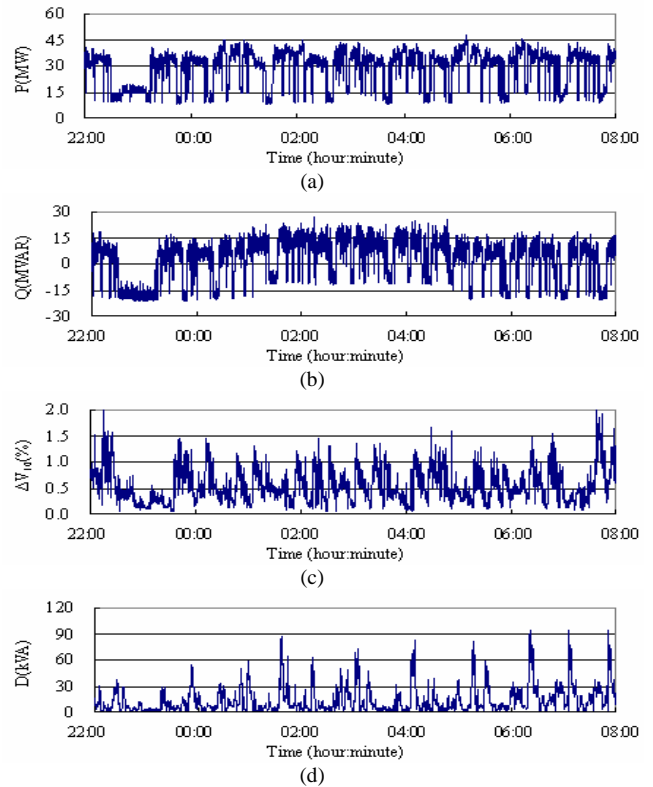

Fig. 11. Fields  $P$ ,  $Q$ ,  $\Delta V_{10}$  and  $D$  measured results based on a rate of 1sample/min. at the service entrance point of factory A1

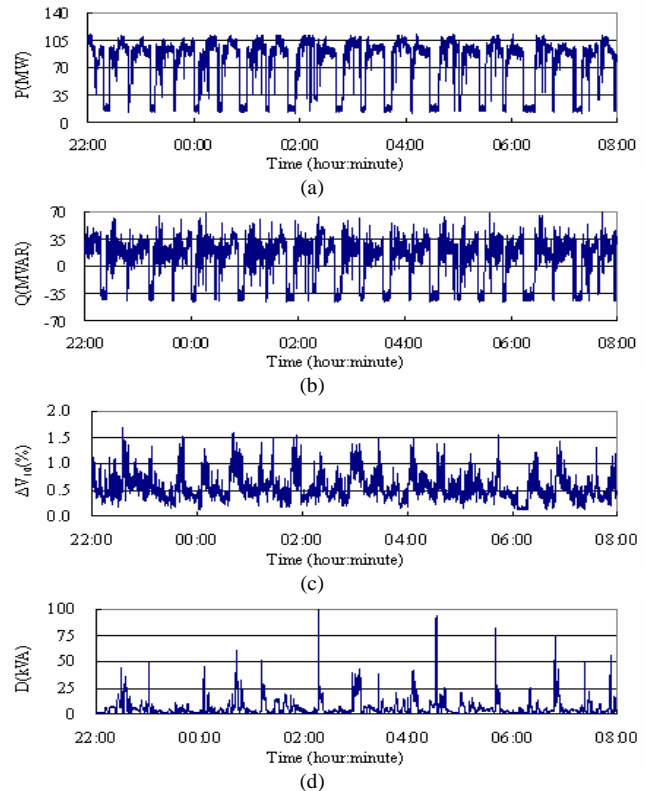

Fig. 12. Fields  $P$ ,  $Q$ ,  $\Delta V_{10}$  and  $D$  measured results based on a rate of 1sample/min. at the service entrance point of factory D1

Figure 11 shows the survey results of factory A1, revealing that the active power is between 9.16MW~41.55MW while the reactive power is between -20.12MVAR~19.04MVAR. The voltage flicker  $\Delta V_{10}$  value is between 0.102%~1.277% while the harmonic power D value is between 0.60kVA~54.09kVA. Figure 12 shows the survey results of factory D1, revealing that the active power is between 14.62MW~106.73MW while the reactive power is between -44.25MVAR~42.92MVAR. The voltage flicker  $\Delta V_{10}$  value is between 0.164%~1.122% while the harmonic power D value is between 0.23kVA~25.0kVA.

Figs. 11 and 12 clearly show extreme variations of P and Q in the EAF loads. Usually, the ac EAF factories install compensation equipment such as Thyristor Q Compensator (TQC). Nevertheless, dc EAF factories commonly only have install filters. The reactive power supply sometimes exceeded the demand, causing Q to be negative. Meanwhile, the reactive power flows to the utility. However, the real power of EAFs varies widely, and in turn increasing  $\Delta V$ . The survey results indicate that the variation of the EAF's voltage is unusually severe. Clearly, an estimate of  $\Delta V_{10}$  cannot ignore the effect of active power variation to ensure that the error in the estimate is sufficiently small. Besides, the  $\Delta D$  may be another major cause of voltage flicker when the harmonic power has been enlarged. Similarly, the survey results of P, Q, D and  $\Delta V_{10}$  values of factories A2 and A3 are also analyzed. Table 3 lists the field survey of the EAF factories A1, A2, A3 and D1.

Table 3. Statistical results of P, Q, D and  $\Delta V_{10}$  on field survey of the EAF factories

Factory Name		P (MW)	Q (MVAR)	$\Delta V_{10}$ (%)	D (kVA)
A1	95% Cumulative Probability Value	40.50	17.57	1.132	43.32
A2		23.19	-2.14	1.100	19.81
A3		34.00	7.40	1.105	21.41
D1		105.13	37.90	1.004	18.85

When EAF is operated after installation, the power company and steel factories must assess the influence of EAF on power systems. Before installing the EAF, the capacities of facilities to reduce voltage flicker must be estimated. Owing to considerable EAF load variation in steel factories, the non-linear phenomenon clearly follows the degree of melting of scrap iron. Regarding the estimation of the severity of voltage flicker, part

circuits and load parameters were often ignored or assumed owing to an inability to obtain their true parameters. However, in accordance with tradition, MRPFM is generally used to estimate the  $\Delta V_{10}$  value of the EAF.

According to the previous analysis, an estimate related problem exists. Before installing the EAF, EAF factory using the uses the traditional method to ensure that the estimated value of  $\Delta V_{10max}$  is below the permitted value. Meanwhile, the limitation of  $\Delta V_{10}$  and permitted by the TPC is 0.45%, and thus is used herein. Nevertheless, the survey value clearly exceeds the design value, thus showing that further investigation of this case is required.

The question arises of why the  $\Delta V_{10max}$  survey value is significantly greater than the permitted value (=0.45%). Briefly, the key to answering this question lies in how the  $\Delta Q_{max}$  value of the EAF is calculated. Obviously, the  $\Delta Q_{max}$  value of the original design is too small to respond the actual variation of apparent power S. Meanwhile, the difference between design value and actual value is quite big and is the main reason for the  $\Delta V_{10max}$  value of the original design being smaller than the survey value.

However, this investigation suggests that the  $\Delta V_{10}$  estimate calculation must adopt a stricter standard when utilizing the MRPFM. Therefore, we refer to the standards and experience of research. Finally, the formula for calculation  $\Delta V$  is modified, as represented by Eq. (6).

$$|\Delta V| = X_s \sqrt{\Delta P^2 + \Delta Q^2 + \Delta D^2} \tag{6}$$

### 5 Conclusion

The EAF loads of more than four steel factories have been extensively surveyed during the past several years. Meanwhile, these investigations found that the estimated  $\Delta V_{10}$  is lower if the conventional means of estimating criteria is applied. Because the severity of the EAF caused voltage flicker problem was under-estimated, some factories did not install any compensation equipment, and others failed to install sufficient compensation equipments. Both the utilities and factories are confused by this mismatch between theoretical estimation and actual measurement of  $\Delta V_{10}$ .

The ultimate cause of the mismatch was that the  $\Delta V$  estimates of the EAF is insufficient, but we suggest that the formula (6), developed here, should be adopted to replace the traditional formula when

utilizing the MRPFM to calculate  $\Delta V_{10}$ . Then, the accurate capacity of compensation equipment can be estimated and installed in advance. Thereafter, the voltage flicker problems will be effectively improved.

*References:*

- [1] IEEE Standard Dictionary of Electrical and Electronics Terms, IEEE Std. 100, 1984.
- [2] G. T. Heydt, Electric Power Quality, Stars in a Circle Publication, Indiana, 1994.
- [3] IEC Publication 868: Flicker-Meter, functional and design specification, 1986.
- [4] *New trend in supply problems of arc furnace for steel plants*, Japanese: Elect. Eng. Soc., 1978, vol.2, no.72, pp.3-26.
- [5] G. Manchur and C. C. Erven, "Development of A Model for Predicting Flicker from Electric Arc Furnaces," *IEEE Trans. Power Delivery*, vol. 7, no. 1, pp. 416-426, Jan.1992.
- [6] G. C. Montanari, M. Loggini, A. Cavallini, L. Pitti, and D. Zaninelli, "Arc Furnace Model for The Study of Flicker Compensation in Electrical Networks," *IEEE Trans. on Power Delivery*, vol.9, no.4, pp.2026-2036, 1994.
- [7] J. C. Gu, C. J. Wu, and J. C. Chiang, "Effects of High Voltage Side Voltage Flicker Sources on Low Voltage Side Customers," Power Research Institute, Taiwan Power Company, 1994.
- [8] C. J. Wu and L. H. Lee, "Electric Power Quality Evaluation of 161kV Large Size Steel Plants," Power Research Institute, Taiwan Power Company, 1995.
- [9] C. J. Wu and J. C. Gu, "Measurement and Analysis of Voltage Flicker," Power Research Institute, Energy Commission, Ministry of Economic Affairs, Technical Report, 2000.
- [10] J. L. Guan, J. C. Gu, and C. J. Wu, "Real-time Measurement Approach for Tracking the Actual Coefficient of  $\Delta V / \Delta V_{10}$  of Electric Arc Furnaces," *IEEE Trans. on Power Delivery*, vol. 19, no. 1, pp. 309-315, Jan. 2004.
- [11] J. L. Guan, J. C. Gu, and C. J. Wu, "A Novel Method for Estimating Voltage Flicker," *IEEE Trans. on Power Delivery*, vol. 20, no. 1, pp. 242-247, Jan. 2005.
- [12] J. D. Lavers and P. P. Biringer, "Real-Time Measurement of Electric Arc Furnace Disturbances and Parameter Variations," *IEEE Trans. on Industry Applications*, Vol. 22, No. 4, pp. 568-577, 1986.