

# Efficient Symmetric Boundary Condition for Galerkin Finite Volume Solution of 3D Temperature Field on Tetrahedral Meshes

SAEED-REZA SABBAGH-YAZDI

KN Toosi University of Technology,  
Civil Engineering Department,  
No.1346 Valiasr Street, 19697- Tehran, IRAN

and

NIKOS E. MASTORAKIS

Military Institutes of University Education (ASEI)  
Hellenic Naval Academy  
Terma Chatzikyriakou 18539, Piraeus, GREECE

## *Abstract:*

In some of the engineering problems, it is necessary to analyze the three-dimensional temperature profiles. In order to solve a typical problem numerically, the three-dimensional temperature diffusion equation is chosen as the mathematical model. The finite volume formulation is derived using Galerkin approach for the mesh of tetrahedral elements, which facilitates solving temperature problems with complicated geometries. In this approach, the Poisson equation is multiplied by the piece wise linear shape function of tetrahedral element and integrated over the control volumes which are formed by gathering all the elements meeting every computational node. The linear shape functions of the elements vanish by some mathematical manipulations and the resulted formulation can be solved explicitly for each computational node. The algorithm not only is able to handle the essential boundary conditions but also the natural boundary conditions using a novel technique. Accuracy and efficiency of the algorithm is assessed by comparison of the numerical results for a bench mark problem of heat generation and transfer in a block with its analytical solution. Then, introduced technique for imposing natural boundary conditions on unstructured tetrahedral mesh is examined for cases with inclined symmetric boundaries.

*Key-Words:* Numerical Simulation of Heat Transfer, Galerkin Finite Volume Method, Symmetric Boundary Conditions

## **1 Introduction**

Availability of the fast and powerful personal computers motivates the use of numerical methods for solving temperature fields of engineering applications. In order to predict the thermal behavior of the solid states with internal source of heat generation rate several numerical solvers are developed using various methods such as Finite Difference Methods, Finite Element Methods and Finite Volume Methods. The Finite Difference Methods [1] convert differential form of the governing equations to simple formulations in the expense of some errors which degrades the accuracy of the numerical solutions. But the main problem of the Finite Difference Methods is serious difficulties in their application to solve real world problems due to necessity of the use of structured grids for geometric discretization. The Finite Element Method [2] and Boundary Element Method [3] overcome the aforementioned problem by application of sophisticated mathematical manipulations on the integral form of the governing equations formulations which end up with complicated solution procedures. Consequently, the Finite

Element Methods not only can handle complex geometries but also provide accurate numerical solutions for the boundary value problems. However, their heavy computational work loads, time-consuming complicated matrix computations and implicit solutions of real world applications with geometrical complexities some times are beyond the available hard ware efficiencies. The traditional Finite Volume Methods [4] convert the integral form of the governing equations for spatial problems into simple algebraic formulations. These methods may have some advantages over the Finite Difference Methods but the required structured meshes bring up major restrictions and errors with modeling of domains with complex geometries and irregular boundaries. The Finite Volume Methods suitable for the unstructured meshes [5] can handle the geometrical complexities using relatively simple formulations and computational procedures. Therefore, if the developed algorithm of these types of Finite Volume Method can satisfy the accuracy requirements of the desired problem, it would be an efficient means of computer simulations of the

engineering applications on ordinary hard ware systems.

In this paper, three dimensional finite volume heat transfer solver module of NASIR (Numerical Analyzer for Scientific and Industrial Requirements) software is introduced. In this paper, the numerical solution algorithm of this software for the temperature field under the effects of internal heat generation rate as well as essential and natural boundary conditions is described. Here, the unstructured finite volume solution algorithm introduced for the viscous flow computations [6] is adopted for temporal solution of diffusive equation of heat generation and transfer.

The governing equation is multiplied by the piece wise linear shape function of tetrahedral elements of an unstructured mesh and then it is integrated over all control volumes formed by the elements meeting every computational node (vertices of the elements). The algorithm takes advantage from the fact that the first derivatives of the linear interpolation function for the temperature are constant inside each element. By application of Gauss divergence theorem and using the property of the linear shape function, which satisfies homogeneous boundary condition on the dependent variable, the boundary integral terms can be omitted for every control volumes using surrounding nodal values. After some manipulations, the resulting formulations can be solved explicitly with rather light computational efforts [7].

Using a novel numerical technique for imposing natural boundary conditions symmetric boundaries are used for reducing computational efforts. Hence, an efficient solver is developed for the solution of three-dimensional temperature fields with complex boundaries which geometrically can be modeled by the use of unstructured mesh of tetrahedral elements. In order to assess the performance of the developed solver, the numerical solution results of temperature in a typical block are compared with its analytical solution.

## 2 Governing equation

Assuming isotropic thermal properties for the solid materials, the familiar equation defining heat generation and transfer is of the form,

$$\alpha \left( \frac{\partial^2 T}{\partial x_1^2} + \frac{\partial^2 T}{\partial x_2^2} \right) + \frac{\alpha}{\kappa} \dot{Q} = \frac{\partial T}{\partial t} \quad (1)$$

Where the parameters are  $\rho$  ( $Kg/m^3$ ) density,

$C$  ( $KJ/Kg^\circ c$ ) specific heat,  $T$  ( $^\circ c$ ) temperature,  $\kappa$  ( $W/m^\circ c$ ) heat conduction coefficient and  $\dot{Q}$  ( $KJ/m^3 h$ ) rate of heat generation per unit volume and the thermal diffusion is defined as  $\alpha = \kappa / \rho C$ .

## 3 Numerical Simulation

Although for the solution of relatively simple phenomenon analytical procedures can be considered, for the majority of the cases analytical solutions are impossible or very restrictive. As an alternative, numerical method can be an efficient and powerful means of solutions for such cases. Several attempts have been made to solve transient heat transfer equations using well-known methods such as the finite difference, finite volumes and finite elements methods. Each of them has its own shortcomings and difficulties. Here, an algorithm is described for the numerical solution on unstructured mesh of tetrahedral.

The derivation of the discrete formulations starts using Galekin approach. The manipulations end up with a discrete equation without the linear shape function of element and it can be solved explicitly for every computational node surrounded by the elements. This numerical technique can accurately solve the three-dimensional temperature field with complex boundaries with considerable efficiency achievement.

Consider the governing equation for heat generation and transfer in a homogenous domain as,

$$\frac{\partial T}{\partial t} + \frac{\partial}{\partial x_i} \left( \alpha \frac{\partial T}{\partial x_i} \right) = S \quad (i=1,2,3) \quad (2)$$

Where  $T$  (temperature) is the unknown parameter and  $S$  is the heat source. If temperature gradient flux in  $i$  direction (secondary variable) is defined as,

$$F_i^d = \alpha \frac{\partial T}{\partial x_i} \quad (i=1,2,3) \quad (3)$$

And hence, the equation takes the form:

$$\frac{\partial T}{\partial t} + \left( \frac{\partial}{\partial x_i} F_i^d \right) = S \quad (i=1,2,3) \quad (4)$$

By application of the Variational Method, after multiplying the residual of the above equation by the

test function  $\phi$  and integrating over a sub-domain  $\Omega$ , we have,

$$\int_{\Omega} \frac{\partial T}{\partial t} \phi \, d\Omega + \int_{\Omega} \frac{\partial F_i^d}{\partial x_i} \phi \, d\Omega = \int_{\Omega} S \phi \, d\Omega \quad (i=1,2,3) \quad (5)$$

The terms containing spatial derivatives can be integrated by part over the sub-domain  $\Omega$  and then equation (5) may be written as,

$$\int_{\Omega} \frac{\partial T}{\partial t} \phi \, d\Omega + \int_{\Omega} F_i^d \phi \, d\Omega - \int_{\Omega} F_i^d \frac{\partial \phi}{\partial x_i} \, d\Omega = \int_{\Omega} S \phi \, d\Omega \quad (i=1,2,3) \quad (6)$$

Using Gauss divergence theorem the equation takes the form:

$$\int_{\Omega} \frac{\partial T}{\partial t} \phi \, d\Omega + \alpha \oint_{\Gamma} \phi T \, d\Gamma - \int_{\Omega} F_i^d \frac{\partial \phi}{\partial x_i} \, d\Omega = \int_{\Omega} S \phi \, d\Omega \quad (i=1,2,3) \quad (7)$$

Where  $\Gamma$  is the boundary of domain  $\Omega$ .

Following the concept of weighted residual methods, by considering the test function equal to the weighting function, the dependent variable inside the domain  $\Omega$  can be approximated by application of a linear combination, such as  $T = \sum_{k=1}^{N_{nodes}} T_k \phi_k$  [8].

According to the Galerkin method, the weighting function  $\phi$  can be chosen equal to the interpolation function  $\phi$ . In finite element methods this function is systematically computed for desired element type and called the shape function. For a tetrahedral type element (with four nodes), the linear shape functions,  $\phi_k$ , takes the value of unity at desired node  $n$ , and zero at other neighboring nodes  $k$  of each triangular element ( $k \neq n$ ) [9].

Extending the concept to a sub-domain to the control volume formed by the elements meeting node  $n$  (Figure 1), the interpolation function  $\phi_n$  takes the value of unity at the center node  $n$  of control volume  $\Omega$  and zero at other neighboring nodes  $m$  (at the boundary of the control volume  $\Gamma$ ). Noteworthy that, this is an essential property of weight function,  $\phi$ , which should satisfy homogeneous boundary condition on  $T$  at boundary of sub-domain [3]. That is why the integration of the linear combination  $T = \sum_{k=1}^{N_{nodes}} T_k \phi_k$  (as approximation) over elements of sub-domain  $\Omega$

takes the value of  $T_n$  (the value of the dependent variable in central node  $n$ ). By this property of the shape function  $\phi$  ( $\phi_n = 0$  on boundary  $\Gamma$  of the sub-domain  $\Omega$ ), the boundary integral term in equation (7) takes zero value for a control volume which the values of  $T$  assumed known at boundary nodes.

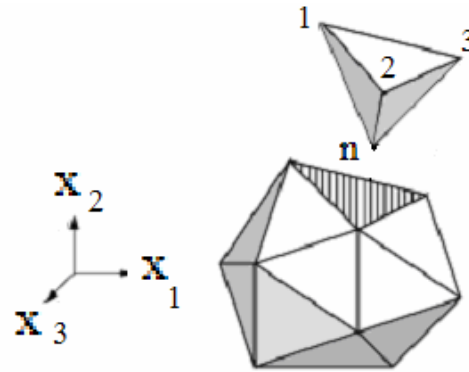

Figure 1 - Sub-domain  $\Omega$  associated with node  $n$  of the computational field

After omitting zero term, the equation (7) takes the form,

$$\frac{\partial}{\partial t} \int_{\Omega} T \phi \, d\Omega - \int_{\Omega} F_i^d \frac{\partial \phi}{\partial x_i} \, d\Omega = \int_{\Omega} S \phi \, d\Omega \quad (i=1,2,3) \quad (8)$$

In order to drive the algebraic formulation, every single term of the above equation first is manipulated for each element then the integration over the control volume is performed. The resulting formulation is valid for the central node of the control volume.

For the terms containing no derivatives of the shape function  $\phi$ , an exact integration formula is used as

$$\int_{\Lambda} \phi_1^a \phi_2^b \phi_3^c \phi_4^d = 6\Lambda (a!b!c!d!) / (a+b+c+d+3) = \Lambda/4$$

(for  $a=1$  and  $b=c=d=0$ ), where  $\Lambda$  is the volume of the tetrahedral element [6]. This volume can be computed by the integration formula as,

$$\Lambda = \int_{\Lambda} x_i (d\Lambda)_i \approx \sum_k^4 [\bar{x}_i \delta \ell_i]_k \quad \text{where } \bar{x}_i \text{ and } \delta \ell_i \text{ are the average } i \text{ direction coordinates and projected area (normal to } i \text{ direction) for every side face opposite to node } k \text{ of the element.}$$

Therefore, the transient term  $\frac{\partial}{\partial t} \int_{\Omega} \phi T \, d\Omega$  for each tetrahedral element  $\Lambda$  (inside the sub-domain) can be written as,  $\frac{\partial}{\partial t} \int_{\Lambda} \phi T \, d\Lambda = (\Lambda/4) dT/dt$ . Consequently, the transient term of equation (8) for

the sub-domain  $\Omega$  (with central node  $n$ ) takes the form,

$$\frac{\partial}{\partial t} \int_{\Omega} \varphi T d\Omega = \frac{\Omega_n}{4} \frac{dT_n}{dt} \quad (9.a)$$

Similarly, the source term of equation (8),  $\int_{\Omega} S \varphi d\Omega$ , for each element  $\Lambda$  (inside the sub-domain), will be written as,

$\int_{\Lambda} \varphi S d\Lambda = (\frac{\Lambda}{4}) S$ . Then the source term of the equation (8), for the control volume  $\Omega$  (with central node  $n$ ) takes the form,

$$\int_{\Omega} \varphi S d\Omega = \frac{\Omega_n}{4} S_n \quad (9.b)$$

Now we try to discrete the terms containing spatial derivative,  $\int_{\Omega} F_i^d (\frac{\partial \phi}{\partial x_i}) d\Omega$  in equation (8).

Since the only unknown dependent variable is  $T = \sum_k^4 T_k \varphi_k$  and the shape functions,  $\varphi_k$ , are chosen piece wise linear in every tetrahedral element, the temperature gradient flux ( $F_i^d$  is formed by first derivative) is constant over each element and can be taken out of the integration. On the other hand, the integration of the shape function spatial derivation over tetrahedral element can be converted to boundary integral using Gauss divergence theorem [9], and hence,

$\int_{\Lambda} \frac{\partial \varphi}{\partial x_i} d\Lambda = -\oint_{\Delta} \varphi (d\Delta)_i$ . Here  $\Delta$  is component of the side face element normal to the  $i$  direction. The discrete form of the line integral can be written as,

$\oint_{\Delta} \varphi (d\Delta)_i \approx \frac{1}{\Lambda} \sum_k^4 [\bar{\varphi} \delta \ell_i]_k$ , where  $[\bar{\varphi} \delta \ell_i]_k$  is formed by considering the side of the element opposite to the node  $k$ , and then, multiplication of its component perpendicular to the  $i$  direction by  $\bar{\varphi}$  the average shape function value of its three end nodes. Hence, the term

$\int_{\Omega} F_i^d (\frac{\partial \phi}{\partial x_i}) d\Omega \approx -\sum_n^N [F_i^d / \Lambda \sum_k^4 (\bar{\varphi} \delta \ell_i)_k]$  for a control volume  $\Omega$  (containing  $N$  elements sharing its central node). Since the shape function  $\varphi$  takes the value of unity only at central node of control volume and is zero at the nodes located at the boundary of control volume,  $\bar{\varphi} = 1/3$  for the faces connected to the central node of control volume and  $\bar{\varphi} = 0$  for the boundary faces of the control volume. On the

other hand the sum of the projected area (normal to  $i$  direction) of three side faces of every tetrahedral element equates to the projected area of the fourth side face, hence the term containing spatial derivatives in  $i$  direction of the equation (8), can be written as,

$$\int_{\Omega} F_i^d \frac{\partial \varphi}{\partial x_i} d\Omega = -\frac{1}{3} \sum_{m=1}^M [F_i^d \delta \ell_i]_m \quad (9.c)$$

Where  $[\delta \ell_i]_m$  is the component of the boundary face  $m$  (opposite to the central node of the control volume  $\Omega$ ) perpendicular to  $i$  direction. Note that,

$F_i^d$  is computed at the center of tetrahedral element of the control volume, which is associated with side  $m$ . The temperature gradient flux in  $i$  direction,  $F_i^d = \alpha \frac{\partial T}{\partial x_i}$ , at each tetrahedral element can be

calculated using Gauss divergence theorem,  $\int_{\Omega} F_i^d d\Omega = \alpha \int_{\Lambda} \frac{\partial T}{\partial x_i} d\Lambda = -\alpha \oint_{\Delta} T (d\Delta)_i$ , where

$(d\Delta)_i$  is the projection of side faces of the element perpendicular to  $i$  direction. By expressing the boundary integral in discrete form as,

$\oint_{\Delta} T (d\Delta)_i \approx \sum_k^3 (\bar{T} \delta \ell_i)_k$ , for each element inside the control volume  $\Omega$ . Therefore, we have,

$$[F_i^d]_m = -\frac{1}{\Lambda_m} \sum_{k=1}^3 (\bar{T} \delta \ell_i)_k \quad (10)$$

Where,  $\delta \ell_i$  is the component of  $k$ th face of a tetrahedral element (perpendicular to the  $i$  direction) and  $\bar{T}$  is the average temperature of that face and  $\Lambda$  is the volume of the element.

Note worthy that for control volumes at the boundary of the computational domain, central node  $n$  of the control volume  $\Omega$  locates at its own boundary. For the boundary sides connected to the to the node  $n$  there are no neighboring element to cancel the contribution. Hence, their contributions remain and they act as the boundary sides of the sub-domain. Therefore, there is no change to the described procedure for computation of the spatial derivative terms  $\int_{\Omega} F_i^d (\frac{\partial \phi}{\partial x_i}) d\Omega$ .

Finally, using expressions (9.a), (9.b) and (9.c), the equation (8) can be written for a control volume  $\Omega$  (with center node  $n$ ) as:

$$\Omega_n \frac{dT_n}{dt} = \Omega_n S_n - \frac{4}{3} \sum_{m=1}^M [F_i^d \delta \ell_i]_m \quad (i=1,2,3) \quad (11)$$

The volume of control volume,  $\Omega$  can be computed by summation of the volume of the elements associated with node  $n$ .

Remember, the heat source for each node  $n$  in concrete body is defined by  $S_n = \alpha_n \dot{Q}(t_e)_n / \kappa_n$ .

The resulted numerical model, which is similar to Non-Overlapping Scheme of the Cell-Vertex Finite Volume Method on unstructured meshes, can explicitly be solved for every node  $n$  (the center of the sub-domain  $\Omega$  which is formed by gathering elements sharing node  $n$ ). The explicit solution of temperature at every node of the domain of interest can be modeled as,

$$T_n^{t+\Delta t} = T_n^t + \delta t \left[ S_n - \frac{3}{2\Omega_n} \left( \sum_{k=1}^N F_i^d \Delta l_i \right)_n \right] \quad (i=1,2) \quad (12)$$

Now we need to define a limit for the explicit time step,  $\delta t$ . Considering thermal diffusivity as  $\alpha = \kappa / \rho C$  with the unit ( $m^2/s$ ), the criterion for measuring the ability of a material for temperature change. Hence the rate of temperature change can be expressed as,  $\Omega_n / \delta t \approx \alpha_n$ . Therefore, the appropriate size for local time stepping can be considered as,

$$\delta t = \beta \frac{\Omega_n}{\alpha_n} \quad (\beta \leq 1) \quad (13)$$

$\beta$  is considered as a proportionality constant coefficient, which its magnitude is less than unity. For the steady state problems this limit can be viewed as the limit of local computational step toward steady state.

However, there are different sizes of control volumes in unstructured meshes. This fact implies that the minimum magnitude of the above relation be considered. Hence, to maintain the stability of the explicit time stepping the global minimum time step of the computational field should be considered, so,

$$\delta t = \beta \left( \frac{\Omega_n}{\alpha_n} \right)_{\min} \quad (\beta \leq 1) \quad (14)$$

Noteworthy that for the solution of steady state problems on suitable fine unstructured meshes, the use of local computational step instead of global minimum time step may considerably reduce the computational efforts.

## 4 Boundary Conditions

Two types of boundary conditions are usually applied in this numerical modeling. The essential and natural boundary conditions are used for temperature and temperature gradient flux (gradients) at boundaries, respectively [9].

For those boundary nodes where nodal temperatures are to be imposed (essential boundary conditions), there is no need to compute the temperature. Hence, computed temperature at those node have to be replaced by the given certain values at the end of each computational step.

Contrarily, there is no need to change the computed temperature at the boundary nodes where the natural boundary condition is to be imposed. In order to impose a given temperature gradient normal to the boundary faces,  $G$  (the rate of heat exchange per unit volume of the surface), the normal vector of the boundary faces  $\bar{n}_m = (n_{m1}, n_{m2}, n_{m3})$  can be utilized to compute  $\bar{G} = (Gn_{m1}, Gn_{m2}, Gn_{m3})$  at the desired boundaries. Although simple techniques for imposing gradient at boundary can be applied for the cases that the boundary normal is parallel to one of the main directions of coordinate system, computational difficulties arise for the inclined or curved boundaries. For overcoming the problem, the computed gradient flux vector,  $\bar{F}^d = (F_1^d, F_2^d, F_3^d)$ , at the centre of adjacent element may be modified at the end of each computational step. First, the vector of temperature gradient tangent to the desired boundary face is decomposed from the computed gradient at the centre of adjacent element,

$$\bar{F}_{Tangential} = \bar{G} - (\bar{F}^d \cdot \bar{n}_m) \bar{n}_m \quad (15.a)$$

Then, the normal vector of temperature gradient can be imposed as,

$$\bar{F}_{Normal} = |\bar{G}| \bar{n}_m \quad (15.b)$$

Finally, the temperature gradient vector at the centre of element adjacent to the desired boundary face is considered as,

$$\bar{F}_{Modified}^d = \bar{F}_{Tangential} + \bar{F}_{Normal} \quad (16)$$

Using above mention technique the difficulties associated with inclined or curve boundaries are

overcome. Therefore, the proposed technique suites the present algorithm which is adopted for the domains with complex boundaries discretized using unstructured meshes.

### 5 Structured Tetrahedral Meshes

Structured tetrahedral mesh can be generated by considering 5 or 6 tetrahedron between an eight noded cubic mesh spacing (figure2). A general view of two typical meshes which are formed by considering 5 or 6 tetrahedron between an eight noded cubic mesh spacing are presented in figure 3.

### 6 Verification of the model

The accuracy of the solution of spatial derivative terms is investigated by comparison of the results of the numerical solver with the analytical solution of the following steady state diffusion equation (boundary value problem) with a constant source term as [2,9],

$$k \frac{\partial^2 T}{\partial x_i^2} = Q_0 \quad (i = 1,2) \quad (17)$$

in the spatial field of  $\Omega = \{0 < (x, y) < 1\}$ . Considering the constants of the above equation as  $k = 1$  and  $Q_0 = 1$  as well as the boundary conditions at  $x = 1, y = 1$  as  $T = 0$  and  $\frac{\partial T}{\partial n} = 0$  (symmetric boundary conditions) at  $x_1 = 0, x_2 = 0$ . The analytical solution is given by [7],

$$T(x, y) = \frac{1}{2} \left\{ (1 - y^2) + \frac{32}{\pi^3} \sum_{n=1}^{\infty} \frac{(-1)^n \cos [(2n-1)\pi y/2] \cosh [(2n-1)\pi x/2]}{(2n-1)^3 \cosh [(2n-1)\pi/2]} \right\} \quad (18)$$

In order to obtain a temperature field similar to the two dimensional solution of this problem on a section of the cube, the requirement of imposing natural boundary condition is relaxed by doubling the dimension, and hence, essential boundary condition ( $T = 0$ ) is imposed over four the boundaries  $\{(x, y) = -1, 1\}$  and natural boundary condition ( $\frac{\partial T}{\partial n} = 0$ ) at  $\{(z) = -1, 1\}$ . The tetrahedral mesh which is generated by considering 6 tetrahedral between cubic mesh spacing with eight

nodes is presented in figure 3.b. This  $2m \times 2m \times 2m$  mesh is formed by  $11 \times 11 \times 11$  grid points.

The result of the numerical solution of equation (17) is shown in figure 4 in the form of temperature contour maps. The accuracy of numerical solution can be assessed in figures 5 by comparison between the computational and the analytical solution in two directions along the mesh.

### 7 Inclined Symmetric Conditions

In order to assess the performance of introduced technique for imposing natural boundary conditions (i.e. symmetric condition  $\frac{\partial T}{\partial n} = 0$ ), several reductions on computational field is done by dividing the original field into smaller parts (figure 6). As can be seen some of the symmetric surfaces (6.c and 6.d) are inclined.

The computed temperature fields on the meshes presented at figure 6 are shown in figure 7 in the form of color coded maps of temperature. As can be seen the applied technique for imposing natural boundary condition preserves the accuracy of temperature gradients, even on inclined surfaces. The use of proper technique for symmetry condition provides considerable saving in computational efforts.

### 8 Conclusion

The equation of heat generation and transfer is solved on triangular element mesh utilizing linear shape function as an alternative test function. The resulted algorithm provides light explicit computation of time dependent problems. The simplicity of the algorithm makes it easy to program and extension for further developments.

The numerical model was verified in two stages. Firstly, by using a boundary value problem and its analytical solution, the accuracy of the solution of the spatial terms was assessed. The results of the developed model present reasonable agreements to the analytical Secondly, the introduced technique for imposing natural (symmetry) boundary conditions on unstructured tetrahedral mesh is examined for cases with inclined boundary surfaces. The applied technique for imposing natural boundary condition not only preserves the accuracy of temperature gradients on inclined surfaces, but also provides considerable saving in computational efforts by paving the way for application of symmetric inclined boundary surfaces.

References:

- [1] Anderson D.A. , Tannehill J.C. , Pletcher R.H., “Computational Fluid Mechanic and Heat Transfer”, Combridge Hemispher Press , 1984.
- [2] Reddy J.N. and Gartling D.K. , “The Finite Element Method in Heat Transfer and Fluid Dynamics”, CRC Press, 2000.
- [3] Bercia C.A. , Telles J.C.F. , Wrobel L.C. , “Boundary Element Technique Theory and Appication in Engineering” , Springer Verlag , Berlin , 1984
- [4] Patankar S.V., “Numerical Heat Transfer and Fluid Flow”, McGraw Hill, 1980.
- [5] Thompson J.F. , Soni B.K. and Weatherill N.P., Hand book of grid generation, CRC Press, New York, 1999.
- [6] Sykes L.A., “Development of a Two-Dimensional Navier-Stokes Algorithm for Unstructured Triangular Grids”, ARA Report 80, April 1990.
- [7] Sabbagh-Yazdi S.R., Bageri A.R. “Computer Simulation of Cement Heat Generation and Temperature Profiles in Mass Concrete Structures”, IUST International Journal of Engineering Science, No.2, Vol.15, spring 2004.
- [8] Zienkiewicz O.C. and Taylor R.L., "The Finite Element Method, Volume 1 Basic Formulation and Linear Problems", McGraw-Hill, 1988
- [9] Reddy J.N. , “An Introduction to the Finite Element Method”, McGraw-Hill, , 1993

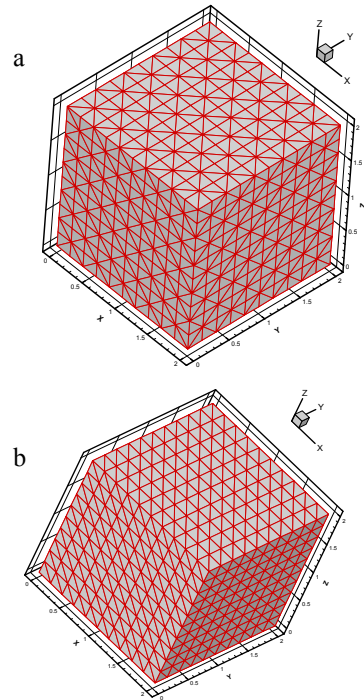

Fig. 3 A general view of two typical meshes which are formed by considering 5 or 6 tetrahedron between an eight node cubic mesh spacing.

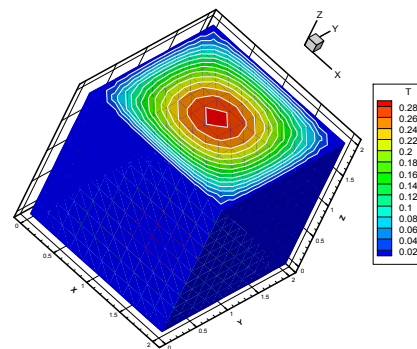

Fig. 4 Computed temperature field in a cubic prism

Figures

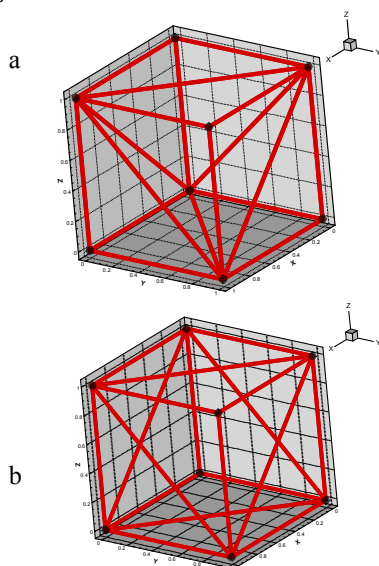

Fig. 2 Two cubic mesh spacing formed by eight nodes which are filled by a) 5 and b) 6 tetrahedral

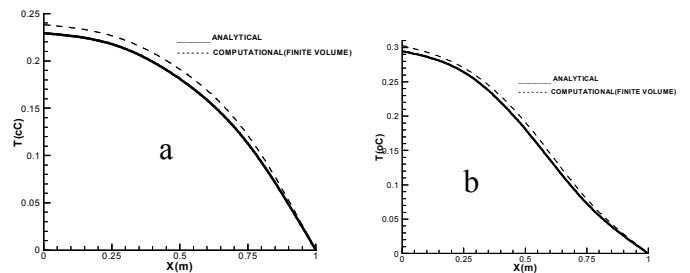

Fig. 5 Comparison between the computational and the analytical solution, a: along the line  $y=0$  ( $0 < x < 1$ ) and ba: along the line  $y=x$  ( $0 < x < 1$ )



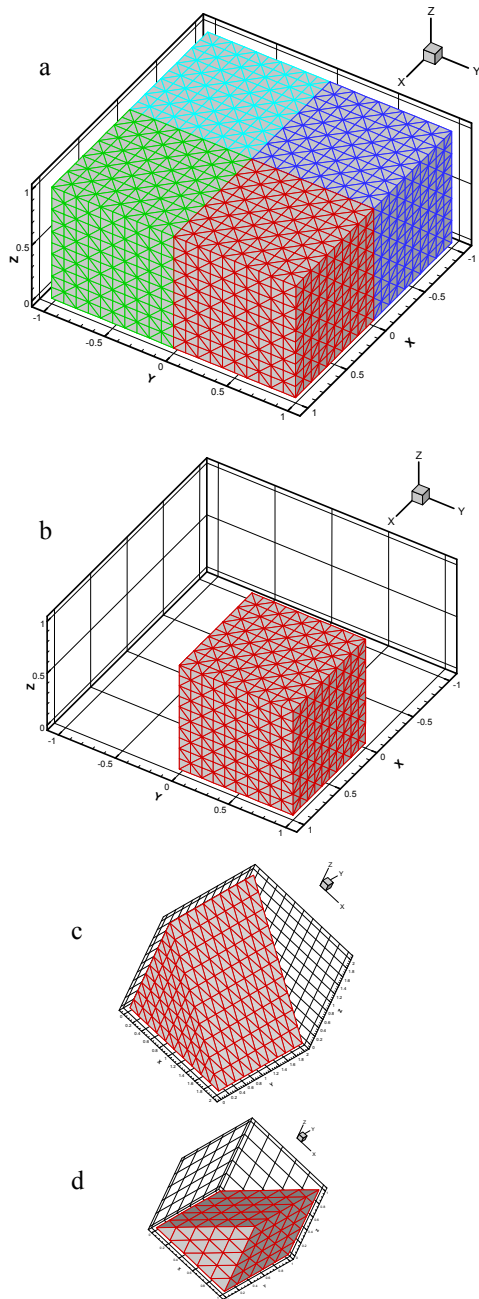

Fig. 6 Using symmetric conditions for dividing the original cubic field into smaller parts as;  
 a) Dividing the original cubic by 2  
 b) Dividing the original cubic by 8  
 c) Dividing the original cubic by 16  
 d) Dividing the original cubic by 64

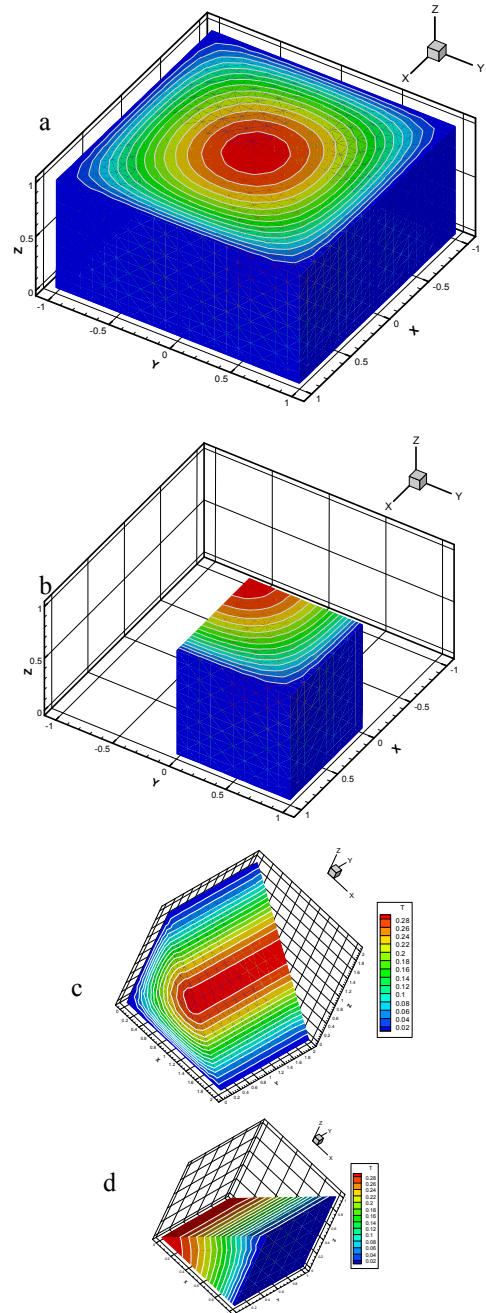

Fig. 7 Using symmetric conditions for temperature field with smaller mesh as;  
 a) Dividing the original cubic by 2  
 b) Dividing the original cubic by 8  
 c) Dividing the original cubic by 16  
 d) Dividing the original cubic by 64