

Analysis of EMI conducted by a PWM inverter - fed AC motor drive

ELEONORA DARIE
Electrical Department
Technical University of Civil Engineering
B-dul Pache Protopopescu 66, Sector 2, Bucharest
ROMANIA

EMANUEL DARIE
Engineering Department
Police Academy
Aleea Privighetorilor 1A, Sector 1, Bucharest
ROMANIA

Abstract: - This work analyses the conducted EMI generated by an inverter-fed induction motor drive system with the pulse with modulation (PWM) as one of the most difficult current technical problem which limits power electronics drive's evolution. The analysis of the impedance characteristics of the converters load (motor and cable) is fundamental to interpret the common and differential mode of emission spectra of the converter. The over-voltage and conducted EMI problems in much application with high power motor and long cable can be clarified by load impedance analysis. The impedance analysis allow to determine the high frequency range where a modeling transmission line based model is evidently necessary, instead of much more simple circuit model.

Key-Words: - Conducted EMI, AC motor, Electrical Drive, PWM, Modeling, High Frequency.

1 Introduction

Electromagnetic Interference (EMI) noise is defined as an unwanted electrical signal that produces undesirable effects in a control system, such as communications errors, degraded equipment performance and malfunction or non-operation. References on the general principles of EMI are available, as well methodologies on calculating radiated emissions. Actually, development of high-speed power semiconductor devices has brought high-frequency switching operation to power electronic equipment, and has improved performance of pulse width-modulated (PWM) inverters for driving AC motors. Increase in the carrier frequency of pulse width modulation and the faster switching rates of the power electronics switches can induce serious problems in many ways. One of the most difficult technical problem to solve, related to this phenomena, is the generation of high frequency currents flowing in all parts of the drive system due to the existence of high levels of the $\Delta U/\Delta t$ in the output voltage. In the adjustable speed drives one can distinguish two components of these currents: differential mode which flows between power lines and common mode flowing between power lines and ground. Each of these currents sources can cause serious application problems such as: conducted and radiated electromagnetic emission (EMI), over voltages in the motor winding, bearing currents and many others. The method of reduction of these unacceptable effects consists in a number of complex analysis to be carried out. To make this

analysis possible, adequate and reasonably complex models are needed. Lumped elements circuit models are mostly recommended and useful for analyzing power electronics converters feeding AC motor by using Spice type simulators. The stray capacitances of the AC motor windings are most consequential parameters which results from its high frequency behavior. For the higher frequencies much more complex models are required to describe load's behavior as a distributed element network. Representing electrical behavior of the AC motor in a wide frequency range by lumped elements circuit model is very effective as far as the parameters of the model are possible to determine with the reasonable effort. The electromagnetic interference (EMI) has been pointed out as a serious problem [1], [5]. A steep change in voltage and/or current caused by high speed switching operation produces high frequency oscillatory common mode and differential mode currents because of the parasitic stray components inevitably existing in an AC drive system. The oscillatory currents can create EMI noises throughout, thus producing a bad effect on electronic devices such a radio receiver and medical equipment. For simulating both common mode and differential mode currents at the same time on utilized an equivalent circuit, where the common-mode current is a high frequency oscillatory current escaping through stray capacitors between motor windings and a frame to a grounding conductor [3], [4].

2 Problem Formulation

AC motor drives are often assembled with an inverter location tens or hundreds meters far from the supplied electric machine. Due to voltage and current wave reflection phenomena across the power line, long connection cables may cause dangerous over voltages at motor terminals, and influence conducted common mode and differential mode electromagnetic emissions. Electric motor drives are often assembled with an inverter location tens or hundreds meters far from the supplied electric machine.

In the inverter motor drives, the PWM pulses generated by the inverter travel along the motor lead cables as shown in Figure 1.

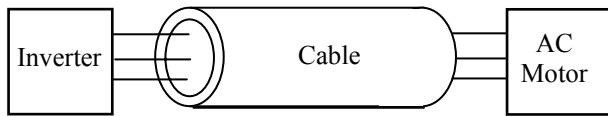

Fig. 1. PWM drive system with connection cables.

PWM generates voltage pulses because of the forward-traveling voltage waves along the connection cable [2]. In a transmission line, voltage wave reflection phenomena take place due to the sudden impedance change occurring at the end of the cable. In fact, as the input impedance of the electric machine is much higher than the cable impedance, the forward traveling voltage waves see a virtually open circuit in correspondence of the motor terminals and are backward reflected with the same sign of the incoming waves. The SPICE model of the drive allows predicting conducted EMI in presence of long cables. The model of the whole inverter is then obtained by connecting the model of the power connection line with a high frequency model of the electric machine and with the circuitual model of the power converter [1].

2.1 Transmission Line Model

Current and voltage oscillations along power connection cables can be studied by using the transmission line theory. The classical model of a lossless transmission line is reported in Figure 2. The lossless power line can be fully characterized by parameters generally reported on cable data sheets or estimated by simple experimental tests. Although simple such model does not take into account the line losses thus giving approximated results.

The model of the transmission line of the cable connecting the motor and inverter is performed for different cable lengths in the range 10 ÷ 30 m.

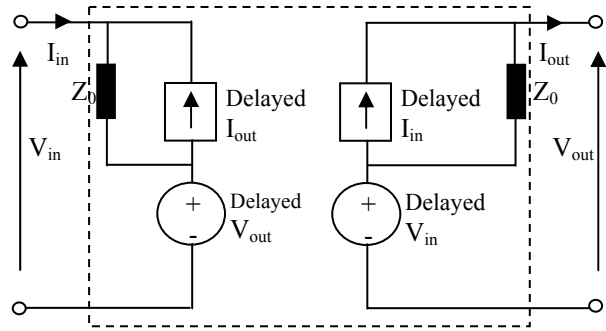

Fig. 2. Model of a lossless transmission line.

2 The model of the AC Motor

AC motor windings physical construction is usually labyrinthine and detailed determination of its capacitance is entirely difficult, the Finite Element Analysis is commonly required. So some simplification should be considered to make this task work more effortless. One of the possible methods to simplify the complex capacitance structure is a lumped elements equivalent circuit model. Figure 3 shows an approximated high frequency model of a star connected machine, composed by a combination of two blocks Y_{PN} and Y_{PG} . The two blocks respectively represent the global high frequency admittances per phase of the current path between phase terminals P (where P stands for L_1, L_2, L_3) and N , the global high frequency admittance of the current paths between terminal P and ground G .

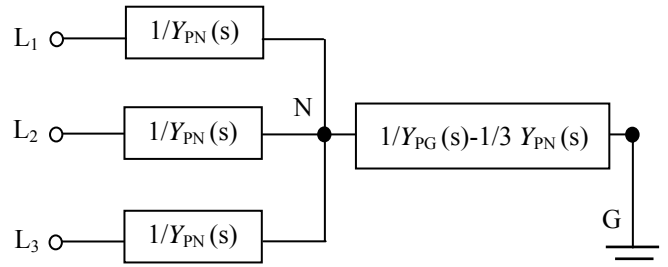

Fig. 3. High frequency model of a star connected AC motor.

The Admittance $Y_{PN}(s)$ can be estimated by supplying the terminals of a single phase of the motor with a sinusoidal voltage generator settled at different frequencies and measuring the amplitude and phase of the current flowing. The Admittance $Y_{PG}(s)$ can be estimated with a similar approach by applying the sinusoidal voltage motor between the shorted input motor terminals and the ground. Results give the frequency diagrams shown in Figure 4. $Y_{PN}(s)$ is characterized by two zeroes, single pole structure, while $Y_{PG}(s)$ shows two zeroes, two poles configuration. In addition, two simple corrective networks can be added in order to improve the high frequency response of both Y_{PN} and Y_{PG} . Consequently, the two

admittances are assumed to have the following expressions:

$$Y_{PN(s)} = k' \frac{s(z_2' s^2 + z_1' s + 1)}{(p_2' s + 1)} \cdot k_c' \cdot \frac{(z_{lc}' s + 1)}{(p_{lc}' s + 1)(p_{2c}' s + 1)} \quad (1)$$

$$Y_{PG(s)} = k'' \frac{s(z_2'' s^2 + z_1'' s + 1)}{(p_2'' s^2 + p_1'' s + 1)} \cdot k_c'' \cdot \frac{(z_{lc}'' s + 1)}{(p_{lc}'' s + 1)(p_{2c}'' s + 1)} \quad (2)$$

Identification of the parameters included in equations (1) and (2) can be performed by considering either the time response of the system either the frequency response [4], [5].

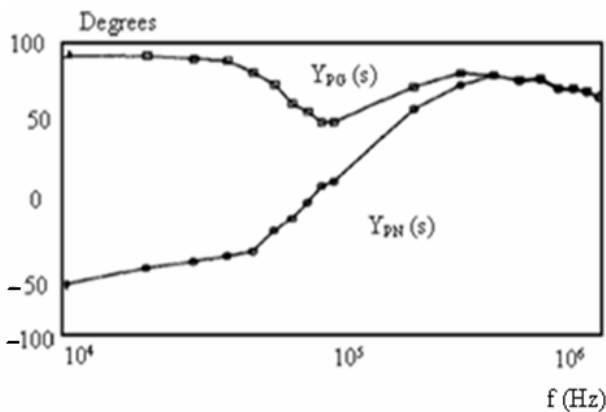

Fig. 3. Frequency diagram.

3 Results

The high frequency drive model can be obtained by integrating the models of the connection cables and the electrical machine. Such a model is used to carry out SPICE simulations of a (AC motor) 2kW drive system, operating at a fixed 15 kHz switching frequency.

3.1 Analysis of the inductance motor impedance

The induction motor's behavior in the high frequency range is hardly related to the impedance characteristics of its windings. The selected examples of AC motor impedance characteristics for the wide range of rated power appear in Figure 4.

The maximum impedance value (about 1 kΩ - 100 kΩ), which can be observed in the resonance frequency range between 30 kHz and 100 kHz for different motors means that in this frequency range or even amplified, there is a minimum load and these spectrum components of motor voltage are only slightly attenuated.

For the frequencies higher then the resonance frequency, the motor behaves as a capacitive load and its impedance decrease 20dB/dec (Fig. 4).

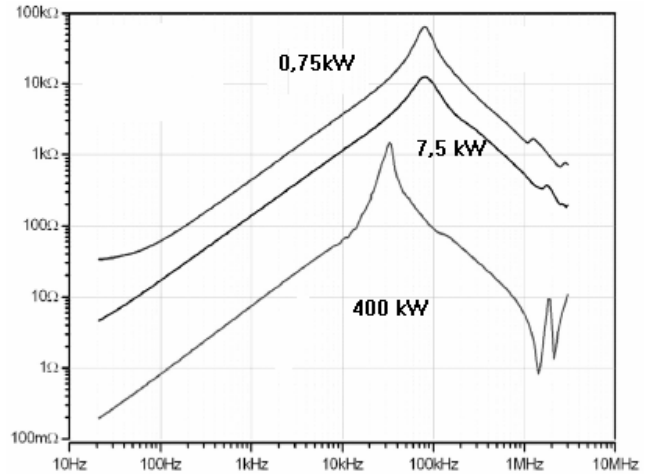

Fig. 4. Comparison of the impedance characteristics of the AC motors for different power.

This capacitive character clearly appears on the impedance characteristics up to several MHz. For the 400kW motor beyond approximately 1MHz the impedance achieve the level below 10 Ω and tends to change regularly. This is the beginning of frequency range where the motor viewed as a load acts as a transmission line. Results of the impedance character change (inductance, capacitance and transmission line) can be also observed in the motor terminal voltage waveforms. The voltage oscillation for the 400kW motor appears in Figures 5 and 6.

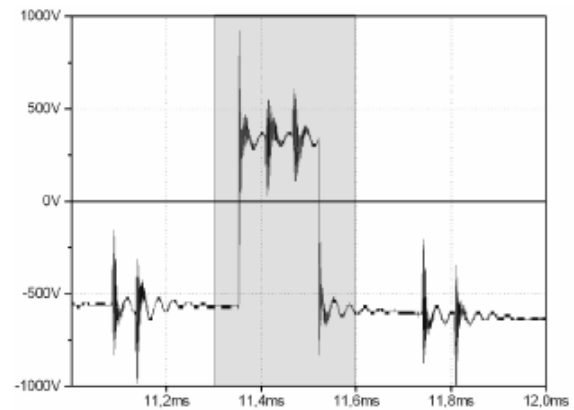

Fig. 5. PWM modulated voltage waveform on the motor terminals – low frequency ringing.

In the Figure 6 are visible to different frequencies of voltage oscillation which starts after each switching process in the converter.

In this waveform it is possible to distinguish two dominant frequencies which are about 30 kHz and 1 MHz. This frequencies are closely correlated to the motor impedance characteristic (Fig. 4) and decide about the predisposition of

the evaluated motor to the high frequency over-voltages.

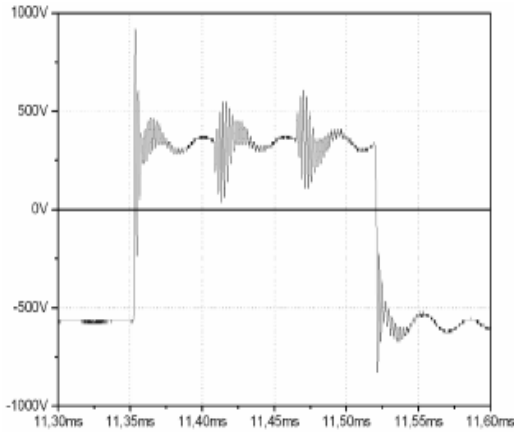

Fig. 6. PWM modulated voltage waveform on the motor terminals – high frequency ringing.

The over-voltage problem noticeably increases when the modulation frequency of the inverter became close to this specific resonance frequency of the motor. The impedance characteristic of the converters load is affected significantly by the motor cable (Fig. 7). The parasitic capacitance of the motor cable moves the resonance frequencies towards to the lower ranges. It is a key reason for critical problems in adjustable speed drives application with long motor cable (over 100 m), where over-voltage and EMC (electromagnetic compatibility) problems appears very often.

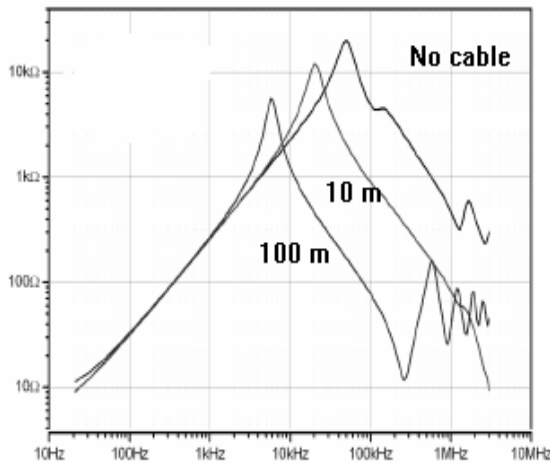

Fig. 7. The influence of the converter – motor - cable on the impedance characteristics.

4 Conclusion

Impedance characteristic of the converters load can be very helpful for analyzing high frequency phenomena in the converter-motor link. The key frequency ranges where many problems appear can be determined based on the impedance characteristics. The over voltage and conducted EMI problems in many of ASD application with high power motor and long cable can be clarified by load impedance analysis. The impedance characteristics analysis allow to determine the high frequency range where for modeling transmission line based model is evidently necessary, instead of much more simple circuit model

References:

- [1] Y. Muray, Leakage Current Reduction for a High-Frequency Carrier Inverter, *IEEE Trans. Industry Applications*, Vol. 28, No.4, 2002, pp. 856-863.
- [2] G.L. Stribinski, R.J. Kerkman, EMI Emissions of modern PWM ac Drives *IEEE Trans. Industry Applications*, Vol. 5, No. 6, 2002, pp. 47-81.
- [3] G. Grandi, D. Casadei, Analysis of Common- and Differential-Mode HF Current Components in PWM Inverter-Fed AC Motors, *IEEE PESC Annual Meeting*, 2001, pp. 1146-1151
- [4] R. Kerkman, D. Leggate, G. Skibinski , Interaction of Drive Modulation & Cable Parameters on AC Motor Transients, *IEEE IAS Annual Meeting*, 2000, pp. 143-152.
- [5] M. Cacciato, A. Consoli, Behavioral High Frequency Model of Motor Phase Windings, *IMACS (Co-Sponsored IEEE) CESA Annual Meeting*, 1998, pp. 121 - 126.